

THIS IS ISSUED IN STRICT CONFIDENCE THAT IT IS NOT USED AS A BASIS FOR MANUFACTURE OR SALE AND THAT IT IS NOT COPIED, REPRINTED OR DISCLOSED TO A THIRD PARTY EITHER WHOLLY OR IN PART WITHOUT THE PRIOR WRITTEN CONSENT OF CAL TEST ELECTRONICS, INC.

NOTES:

1. ALL SPECIFICATIONS SUBJECT TO CHANGE WITHOUT NOTICE.
2. ADAPTER TO MEET OR EXCEED ALL SPECIFICATIONS PER MIL-39012.
3. MATING DIMENSIONS IN ACCORDANCE WITH MIL-STD-348.
4. VSWR AND FREQUENCY RANGE SPECIFICATIONS ARE FOR REFERENCE AND ARE DEPENDANT ON CABLE TYPE AND OTHER APPLICATION SPECIFIC CONDITIONS.
5. MATERIAL:
 - BODY: BRASS, WHITE BRONZE PLATED.
 - CENTER CONTACT: BeCu, GOLD PLATED
 - DIELECTRIC: PTFE
 - GASKET: SILICONE RUBBER
6. ELECTRICAL:
 - IMPEDANCE: 50 Ω
 - FREQUENCY: DC - 3 GHz
 - INSULATION RESISTANCE: 5,000 MΩ MIN
 - DIELECTRIC WITHSTANDING VOLTAGE: 1,000 V MAX @ SEA LEVEL
7. MECHANICAL:
 - TEMPERATURE RANGE: -45°C TO +85°C
8. COUNTRY OF ORIGIN: CHINA
9. RoHS AND REACH COMPLIANT.

| REVISIONS | | | |
|-----------|-----------------|-----------|-----------|
| REV. | DESCRIPTION | DATE | APPROVED |
| A | INITIAL RELEASE | 7/26/2021 | B. HANSEN |

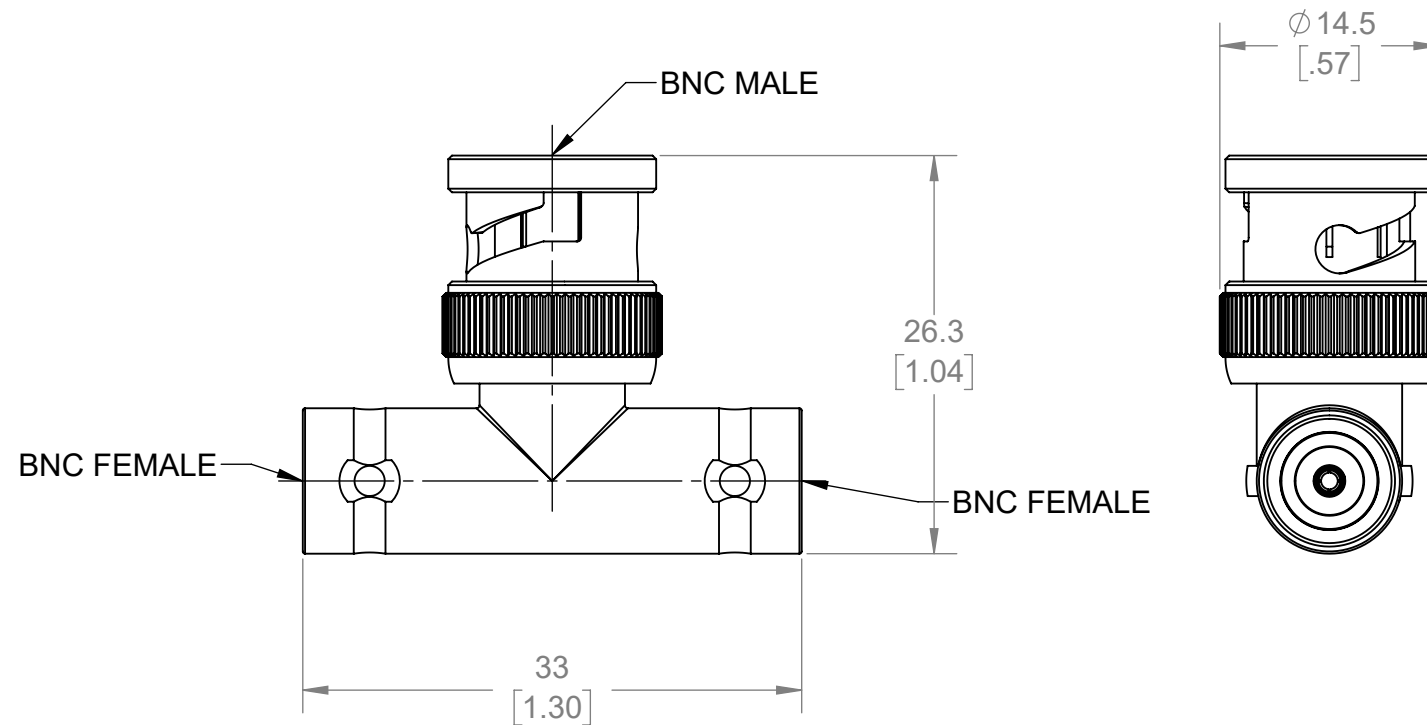

ISOMETRIC VIEW
FULL SCALE

THIRD ANGLE PROJECTION

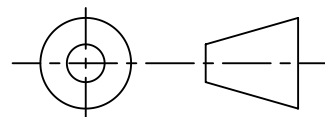

REFERENCE

| | | |
|--------------|---------------|-------------------|
| CT3341A | IN-SERIES | TEE |
| MODEL NUMBER | CONFIGURATION | NOTES / REFERENCE |

MODEL NUMBER TABLE

| | | | | |
|---|-----------------|-----------|-----------|---|
| UNLESS OTHERWISE SPECIFIED DIMENSIONS ARE IN MILLIMETERS TOLERANCES ARE: X.X = ±0.5 X.X* = ±0.5* X.XX = ±0.25 X.XXX = ±0.125 DO NOT SCALE DRAWING | PROJECT NO. | A598 | | 22820 Savi Ranch Prky. Yorba Linda, CA 92887 USA |
| | APPROVALS | DATE | TITLE | |
| MATERIAL | DRAWN | WDH | 7/26/2021 | ADAPTER, BNC TEE, FEMALE TO MALE TO FEMALE, 50 Ω, INSTRUMENT GRADE |
| SEE NOTES | CHECKER | | | |
| TREATMENT | ENGR. | B. HANSEN | 7/26/2021 | SIZE |
| FINISH | DESIGN ACTIVITY | | | CAGE CODE |
| SEE NOTES | | | | B |
| | | | | DWG. NO. |
| | | | | CT3341A |
| | | | | REV. |
| | | | | A |
| | | | | SCALE |
| | | | | 2:1 |
| | | | | SHEET |
| | | | | 1 OF 1 |