

# WT12 Series Mechanical Dynamometer

# TRANSCAT

Visit us at [Transcat.com](http://Transcat.com)

Specification Sheet

SS-WT12-0905

September 2005

35 Vantage Point Drive // Rochester, NY 14624 // Call 1.800.800.5001

The CHATILLON® WT12 Series mechanical dynamometer may be used as a weighing tensiometer or crane scale. This precision weighing instrument features a large 12-inch (305 mm) dial face with shatter-resistant dial cover in a strong aluminum housing. Available with pound or kilogram dial face, the WT12 Series accuracy is better than 0.5% of full scale. A manually engaged clutch “freezes” the pointer at its maximum reading for exact reading of peak weight. Needle bearings in shackles prevent brinneling under heavy loads and eliminate shackle misalignment. Mechanism sealed against dust and dirt. Oiling not required. Dynamometer comes with NIST traceable Certificate of Calibration with Data.

## Features

- Pound or Kilogram Dials
  - Capacities up to 20,000 lb (10,000 kg)
- Rugged Cast Aluminum Housing
- Large, 12-inch (305 mm) Easy-to-Read Dial with Shatter-resistant Dial Cover, Anti-Parallax
- Maximum Reading Button
- Calibration traceable to NIST
- 4:1 Ultimate Safety Factor
- 2 Year Warranty
- Certificate of Calibration with NIST Traceable Data

## Specifications

- Accuracy:** ±0.5% of Full Scale
- Maximum Overload:** 125% of Rated Capacity
- Tare Capacity:** 20% of Rated Capacity
- Dial Revolutions:** Full Scale in 1 Revolution
- Dial Resolution:** 200:1
- Operating Temperature:** -50°F to 140°F (-45°C to 60°C)

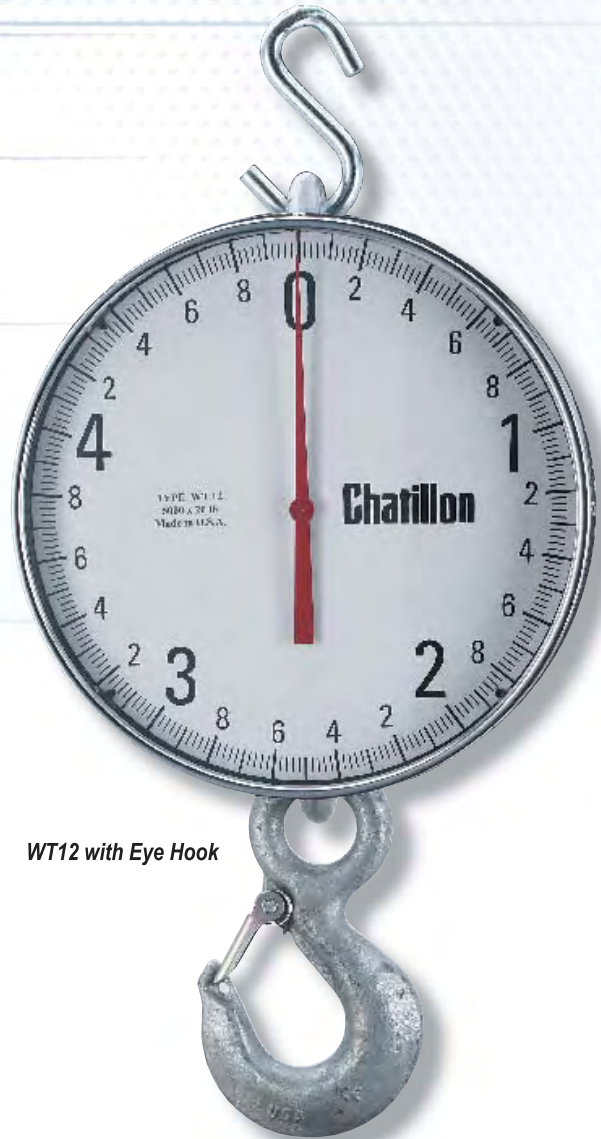

WT12 with Eye Hook

## Ordering

### Scale with Shackles

Model	Capacity	Length
WT12-00500	500 x 2 lb	13-1/4 in (337 mm)
WT12-01000	1000 x 5 lb	13-1/4 in (337 mm)
WT12-02000	2000 x 10 lb	13-1/4 in (337 mm)
WT12-05000	5000 x 20 lb	13-1/4 in (337 mm)
WT12-10000	10000 x 50 lb	15 in (381 mm)
WT12-20000	20000 x 100 lb	15 in (381 mm)
WT12-00500K	500 x 2 kg	13-1/4 in (337 mm)
WT12-01000K	1000 x 5 kg	13-1/4 in (337 mm)
WT12-02000K	2000 x 10 kg	13-1/4 in (337 mm)
WT12-05000K	5000 x 20 kg	15 in (381 mm)
WT12-10000K	10000 x 50 kg	15 in (381 mm)

### With Eye Hook

Model	Capacity	Length
WT12-00500-EH	500 x 2 lb	19-13/16 in (503 mm)
WT12-01000-EH	1000 x 5 lb	19-13/16 in (503 mm)
WT12-02000-EH	2000 x 10 lb	19-13/16 in (503 mm)
WT12-05000-EH	5000 x 20 lb	19-13/16 in (503 mm)
WT12-10000-EH	10000 x 50 lb	26-5/16 in (668 mm)
WT12-20000-EH	20000 x 100 lb	26-5/16 in (668 mm)
WT12-00500K-EH	500 x 2 kg	19-13/16 in (503 mm)
WT12-01000K-EH	1000 x 5 kg	19-13/16 in (503 mm)
WT12-02000K-EH	2000 x 10 kg	19-13/16 in (503 mm)
WT12-05000K-EH	5000 x 20 kg	26-5/16 in (668 mm)
WT12-10000K-EH	10000 x 50 kg	26-5/16 in (668 mm)

### With Swivel Hook

Model	Capacity	Length
WT12-00500-SH	500 x 2 lb	21-1/2 in (546 mm)
WT12-01000-SH	1000 x 5 lb	21-1/2 in (546 mm)
WT12-02000-SH	2000 x 10 lb	21-1/2 in (546 mm)
WT12-05000-SH	5000 x 20 lb	21-1/2 in (546 mm)
WT12-10000-SH	10000 x 50 lb	28-3/8 in (721 mm)
WT12-20000-SH	20000 x 100 lb	28-3/8 in (721 mm)
WT12-00500K-SH	500 x 2 kg	21-1/2 in (546 mm)
WT12-01000K-SH	1000 x 5 kg	21-1/2 in (546 mm)
WT12-02000K-SH	2000 x 10 kg	21-1/2 in (546 mm)
WT12-05000K-SH	5000 x 20 kg	28-3/8 in (721 mm)
WT12-10000K-SH	10000 x 50 kg	28-3/8 in (721 mm)

# Chatillon

A registered trademark of AMETEK Inc.

## Dimensions

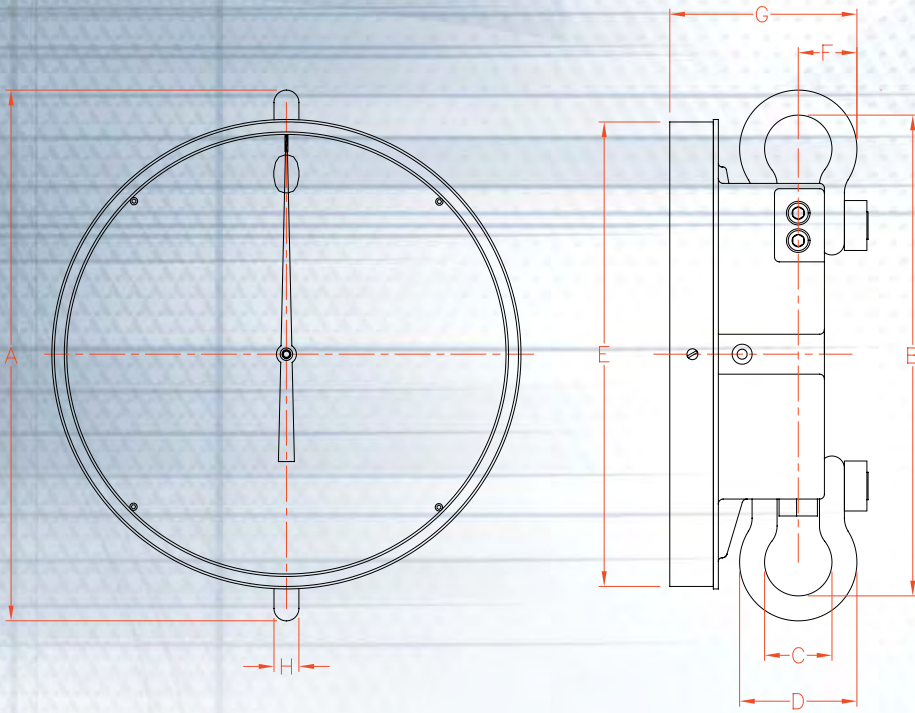

### Dimensions with Shackles

Capacity		A	B	C	D	E	F	G	H
500 - 5000	(inch)	13-1/4	12	1-11/16	3	11-3/4	3-1/8	4-9/16	5/8
	(mm)	337	305	43	76	298	79	116	16
10,000 - 20,000	(inch)	15	13-1/4	1-7/16	3-1/4	11-3/4	3-1/8	4-3/4	7/8
	(mm)	381	337	37	83	298	79	121	22

## Accessories

Part No.	Description
13400	Eye Hook (500 - 5000 lb)
13401	Eye Hook (10,000 - 20,000 lb)
13404	Swivel Hook (500 - 5000 lb)
13405	Swivel Hook (10,000 - 20,000 lb)
20548	Carrying Case, Metal

Notes:  
 Dynamometers with "EH" come standard with Eye Hook.  
 Dynamometer with "SH" come standard with Swivel Hook.  
 Carrying Case must be ordered separately.



Optional Carrying Case



Eye Hook - EH



Swivel Hook - SH

**AMETEK**  
 TEST AND CALIBRATION INSTRUMENTS

**TRANSCAT**

▶ Visit us at [Transcat.com!](http://Transcat.com!)

35 Vantage Point Drive // Rochester, NY 14624 // Call 1.800.800.5001