

Transducers

Models 77 and 771 Current-to-Pneumatic Transducers

Introduction

Features & Benefits

- ▶ High signal sensitivity for demanding applications
- ▶ Simplified design ensures simplified operation
- ▶ Rugged, NEMA construction, with insensitivity to shock, vibration, and supply pressure variations accommodate operation in harsh industrial environments
- ▶ Choice of output capacities provides application versatility

3

Description

The Models 77 and 771 convert a DC millampere input signal to a pneumatic output signal directly proportional to the input. Their rugged design and ability to withstand shock and vibration allow them to be installed in even the harshest industrial environments.

Model 77 Current-to-Pneumatic Transducer

The Model 77 Current-to-Pneumatic Transducer, which was designed specifically for measuring circuits, converts the output of an electronic measuring device to a pneumatic signal for indication, recording, computation, or control. It can also be used to convert an electronic controller's signal to operate a final control element, such as a control valve circuit that requires a high degree of accuracy.

The Model 77 is typically used to signal a valve positioner. If it is used for direct-loading of valve actuators or other large volumes, a volume booster relay is required to minimize time lags and the effects of leakage.

Model 771 Current-to-Pneumatic Transducers

The Model 771 Current-to-Pneumatic Transducers were designed as a cost-effective valve service current-to-pneumatic transducer.

The Model 771 receives the output signal of an electronic device, such as a PID control function, and drives a control valve via the transducer until the control function is satisfied. For measuring circuits, or for control circuits requiring a higher degree of transducing accuracy, the Model 77 should be used.

Because its boosted output capacity minimizes time lags and the effects of leakage, the Model 771B should be used for direct-loading of valve actuators or other large volumes. If the valve actuator includes a valve positioner, a Model 771S should be used.



Specifications – Model 77

Functional Specifications

Supply Pressure

20 psig, ±2 psig for 3-15 psig output
30 psig, ±2 psig for 3-27 psig output

Input/Output Data

See Model Selection

Model 77

For general purpose and non-incendive applications

Model 77F

For intrinsically-safe applications

Zero Offset Adjustment

+40% and -20% of span

Pneumatic Connections

1/4" NPT

Output Capacity

0.16 scfm

Supply Pressure Effect

Less than 1% of span (change of output for supply change from 18 to 22 psig)

Temperature Range

-40 to 180°F (-40 to 82°C)

Electrical Connections

Enclosed terminal block, 1/2" threaded

Transducers

Models 77 and 771 Current-to-Pneumatic Transducers

Technical data

Surface Mounting

Two 1/4 x 20 x 5/16" deep blind tapped holes

Enclosure

NEMA 3R
NEMA 4 via conduit vent

Electrical Classification

FM Approved
Model 77
Non-incendive for Class I, Div. 2, Groups A, B, C, D.
Dust-ignition proof for Class II, Div. 1, Groups E, F, G.
Suitable for Class III, Div. 1 hazardous locations and NEMA 4.
Model 77XXF
Intrinsically safe for Class I/II/III, Div. 1, Groups A, B, C, D, E, F, G and NEMA 4 when used with approved barriers and converters listed on Siemens drawing #15032-7704/7705.

Performance Specifications

Calibration Accuracy

±0.25% of span

Reproducibility

0.2% of span

Response Level

0.025% of span

Model Number

Current-to-Pneumatic
Transducer

Exhaust

- Atmospheric
- Tapped Exhaust

Input/Output

Input Range ¹ (mA dc)	Output Range (psig)	Input Impedence (Ohms)
1 to 5	3 to 15	2450
0 to 4	3 to 15	2450
4 to 20	3 to 27	610
4 to 20	3 to 15	185
10 to 50	3 to 15	30

Intrinsically-Safe Designation

- Intrinsically Safe (omit for other classifications)

Accessories

- Reverse Acting Output

Order No.

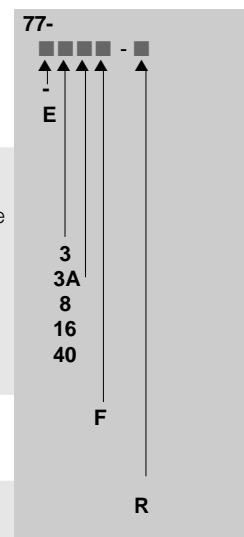

Specifications – Series 771

Functional Specifications

Supply Pressure

20 psig (35 psig for 771-8_ _ _)

Input/Output Data

See Model Selection

Zero Offset Adjustment

+40% and -20% of span

Output Capacity

Standard: 0.16 scfm
Boosted: 2.0 scfm

Supply Pressure Effect

Less than 2% of span (change of output for supply change from 18 to 22 psig)

Temperature Range

-40 to 180°F (-40 to 82°C)

Electrical Connections

Enclosed terminal block, 1/2" threaded

Enclosed

NEMA 3R
NEMA 4 via conduit vent

Electrical Classification

FM Approved
Series 771_ _ _ F1: Intrinsically safe for Class I/II/III, Div. 1, Groups A, B, C, D, E, F, G when used with approved barriers and converters listed on Siemens drawing #15032-7704/7705.

Series 771_ _ _ F2: Non-incendive for Class I, Div. 2, Groups A, B, C, D. Dust-ignition proof for Class II, Div. 1, Groups E, F and G. Suitable for Class III, Div. 1 hazardous locations.

Performance Specifications

Calibration Accuracy

±1/2% of span standard unit
±1% of span boosted unit

Reproducibility

0.2% of span

Response Level

0.025% of span

1) Other input ranges available; 0 - 3 mA to 0-2500 mA.

Transducers

Models 77 and 771 Current-to-Pneumatic Transducers

Ordering data

Model Number

Current-to-Pneumatic Transducer

Input/Output

Input Range ¹ (mA dc)	Output Range (psig)	Input Impedance (Ohms)
1 to 5	3 to 15	2450
4 to 20	3 to 27	610
4 to 20	3 to 15	185
10 to 50	3 to 15	30

Output Capacity

- Boosted
- Standard

Options

- None Required
- Terminal Strip

Electrical Approval

- None Required
- Intrinsically Safe
- Non-incendive

Order No.

771-

■ ■ ■
 ↑ ↑ ↑
 3
 8
 16
 40
 B
 S
 N
 T
 N
 F1
 F2

Accessories

- ▶ P/N 12330-100 - Wall Mount Bracket
- ▶ P/N 12334-130 - Pipe Mounting Bracket
- ▶ Reverse Acting (not available on the Model 771-8)
Increase input; decrease output. Add "R" to model number.

3

Mounting Dimensions – Model 77

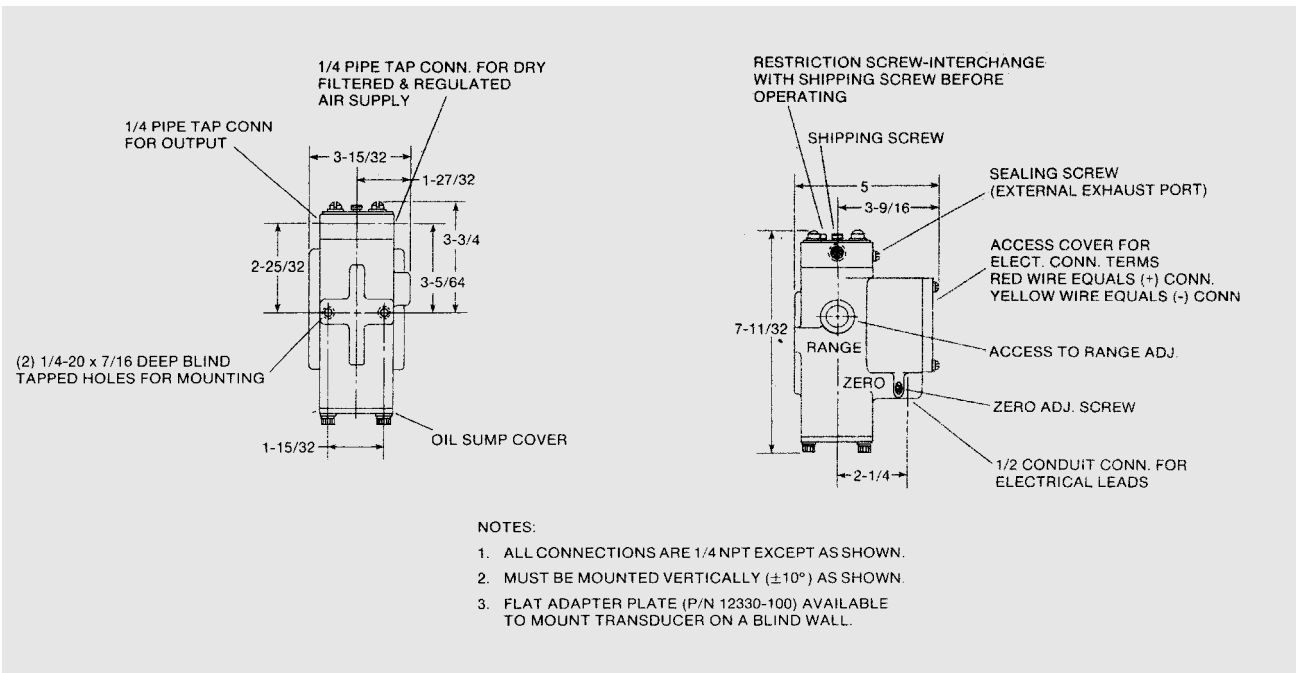

Transducers

Models 77 and 771 Current-to-Pneumatic Transducers

Dimensional drawings

Mounting Dimensions – Model 771 S/B

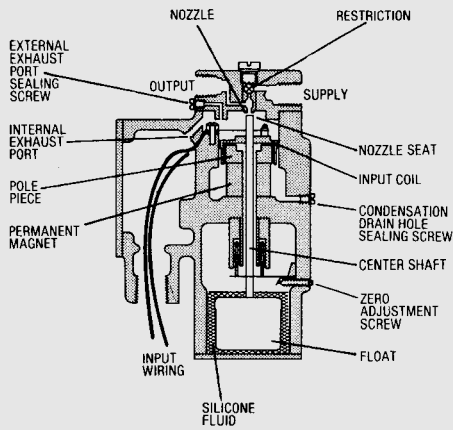

MODEL SERIES 771S
Standard Output Capacity

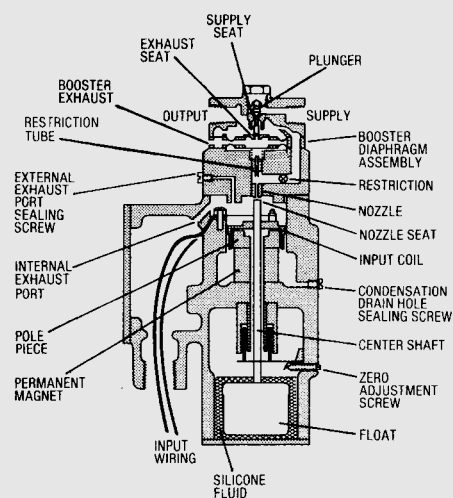

MODEL SERIES 771B
Boosted Output Capacity

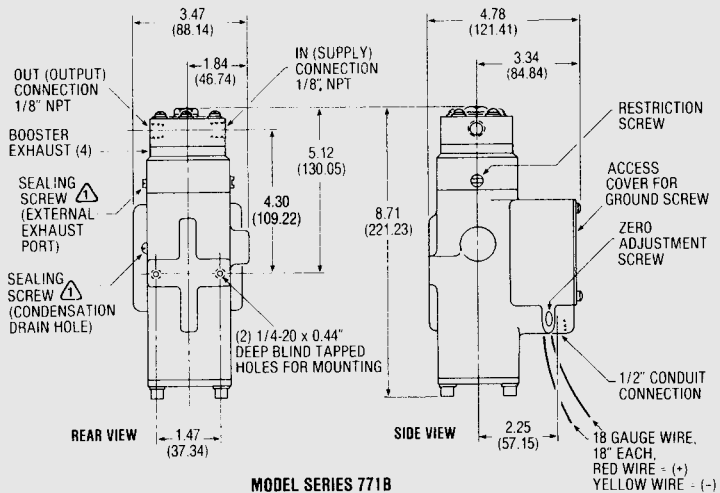
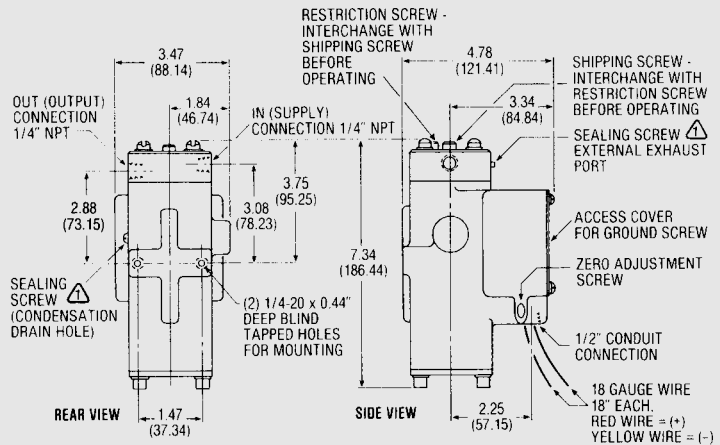

NOTES:

- Sealing screw must not be removed in a Class II hazardous location or under any NEMA 4 condition.
- Dimensions are shown in inches and (millimeters).
- Clearance of at least 5" (127MM) must be left above the top when mounting the transducer to permit removal of shipping and restriction screws and top cap (standard capacity models) and retaining nut (boosted models).
- Transducer must be installed so that water cannot enter booster exhaust under NEMA 4 conditions (boosted models).
- Transducer must be installed within 10° of vertical.