

# 5522A

Multi-Product Calibrator

Service Manual

May 2012

© 2012 Fluke Corporation. All rights reserved. Specifications are subject to change without notice.  
All product names are trademarks of their respective companies.

## **LIMITED WARRANTY AND LIMITATION OF LIABILITY**

Each Fluke product is warranted to be free from defects in material and workmanship under normal use and service. The warranty period is one year and begins on the date of shipment. Parts, product repairs, and services are warranted for 90 days. This warranty extends only to the original buyer or end-user customer of a Fluke authorized reseller, and does not apply to fuses, disposable batteries, or to any product which, in Fluke's opinion, has been misused, altered, neglected, contaminated, or damaged by accident or abnormal conditions of operation or handling. Fluke warrants that software will operate substantially in accordance with its functional specifications for 90 days and that it has been properly recorded on non-defective media. Fluke does not warrant that software will be error free or operate without interruption.

Fluke authorized resellers shall extend this warranty on new and unused products to end-user customers only but have no authority to extend a greater or different warranty on behalf of Fluke. Warranty support is available only if product is purchased through a Fluke authorized sales outlet or Buyer has paid the applicable international price. Fluke reserves the right to invoice Buyer for importation costs of repair/replacement parts when product purchased in one country is submitted for repair in another country.

Fluke's warranty obligation is limited, at Fluke's option, to refund of the purchase price, free of charge repair, or replacement of a defective product which is returned to a Fluke authorized service center within the warranty period.

To obtain warranty service, contact your nearest Fluke authorized service center to obtain return authorization information, then send the product to that service center, with a description of the difficulty, postage and insurance prepaid (FOB Destination). Fluke assumes no risk for damage in transit. Following warranty repair, the product will be returned to Buyer, transportation prepaid (FOB Destination). If Fluke determines that failure was caused by neglect, misuse, contamination, alteration, accident, or abnormal condition of operation or handling, including overvoltage failures caused by use outside the product's specified rating, or normal wear and tear of mechanical components, Fluke will provide an estimate of repair costs and obtain authorization before commencing the work. Following repair, the product will be returned to the Buyer transportation prepaid and the Buyer will be billed for the repair and return transportation charges (FOB Shipping Point).

**THIS WARRANTY IS BUYER'S SOLE AND EXCLUSIVE REMEDY AND IS IN LIEU OF ALL OTHER WARRANTIES, EXPRESS OR IMPLIED, INCLUDING BUT NOT LIMITED TO ANY IMPLIED WARRANTY OF MERCHANTABILITY OR FITNESS FOR A PARTICULAR PURPOSE. FLUKE SHALL NOT BE LIABLE FOR ANY SPECIAL, INDIRECT, INCIDENTAL, OR CONSEQUENTIAL DAMAGES OR LOSSES, INCLUDING LOSS OF DATA, ARISING FROM ANY CAUSE OR THEORY.**

Since some countries or states do not allow limitation of the term of an implied warranty, or exclusion or limitation of incidental or consequential damages, the limitations and exclusions of this warranty may not apply to every buyer. If any provision of this Warranty is held invalid or unenforceable by a court or other decision-maker of competent jurisdiction, such holding will not affect the validity or enforceability of any other provision.

Fluke Corporation  
P.O. Box 9090  
Everett, WA 98206-9090  
U.S.A.

Fluke Europe B.V.  
P.O. Box 1186  
5602 BD Eindhoven  
The Netherlands

# OPERATOR SAFETY SUMMARY

## WARNING

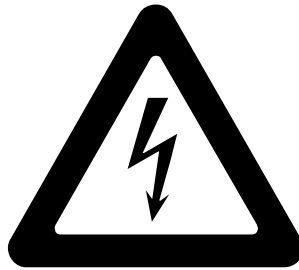

## HIGH VOLTAGE

is used in the operation of this equipment

## LETHAL VOLTAGE

will be present on the inside of this Product and on the terminals.  
Observe all safety precautions!

**To avoid electrical shock hazard, the operator should not electrically contact the output HI or sense HI terminals or circuits connected to these terminals. During operation, lethal voltages of up to 1020 V ac or dc may be present on these terminals.**

**Whenever the nature of the operation permits, keep one hand away from equipment to reduce the hazard of current flowing through vital organs of the body.**



# Table of Contents

Chapter	Title	Page
<b>1</b>	<b>Introduction and Specifications.....</b>	<b>1-1</b>
	Introduction.....	1-3
	Safety Information .....	1-4
	Overload Protection .....	1-5
	Operation Overview.....	1-5
	Local Operation .....	1-5
	Remote Operation (RS-232).....	1-5
	Remote Operation (IEEE-488).....	1-6
	Service Information .....	1-6
	How to Contact Fluke Calibration .....	1-6
	General Specifications .....	1-7
	Detailed Specifications .....	1-8
	DC Voltage.....	1-8
	DC Current .....	1-9
	Resistance.....	1-11
	AC Voltage (Sine Wave).....	1-12
	AC Voltage (Sine Wave) (cont.) .....	1-13
	AC Current (Sine Wave).....	1-14
	AC Current (Sine Wave) (cont.).....	1-15
	Capacitance.....	1-16
	Temperature Calibration (Thermocouple).....	1-17
	Temperature Calibration (RTD).....	1-18
	DC Power Specification Summary.....	1-19
	AC Power (45 Hz to 65 Hz) Specification Summary, PF=1 .....	1-19
	Power and Dual Output Limit Specifications.....	1-19
	Phase.....	1-20
	Additional Specifications.....	1-21
	Frequency .....	1-21
	Harmonics (2 <sup>nd</sup> to 50 <sup>th</sup> ) .....	1-21
	AC Voltage (Sine Wave) Extended Bandwidth .....	1-22
	AC Voltage (Non-Sine Wave).....	1-23
	AC Voltage (Non-Sine Wave) (cont.) .....	1-24
	AC Voltage, DC Offset .....	1-25
	AC Voltage, Square Wave Characteristics.....	1-25

	AC Voltage, Triangle Wave Characteristics (typical).....	1-25
	AC Current (Non-Sine Wave).....	1-26
	AC Current (Non-Sine Wave) (cont.).....	1-27
	AC Current, Square Wave Characteristics (typical).....	1-27
	AC Current, Triangle Wave Characteristics (typical).....	1-27
<b>2</b>	<b>Theory of Operations .....</b>	<b>2-1</b>
	Introduction.....	2-3
	Encoder Assembly (A2).....	2-3
	Synthesized Impedance Assembly (A5).....	2-4
	DDS Assembly (A6).....	2-5
	Current Assembly (A7).....	2-6
	Voltage Assembly (A8).....	2-7
	Main CPU Assembly (A9).....	2-7
	Power Supplies .....	2-8
	Outguard Supplies.....	2-8
	Inguard Supplies.....	2-8
<b>3</b>	<b>Calibration and Verification.....</b>	<b>3-1</b>
	Introduction.....	3-3
	Equipment Necessary for Calibration and Verification.....	3-3
	Calibration .....	3-4
	Start Calibration.....	3-5
	DC Volts Calibration (NORMAL Output).....	3-5
	DC Volts Calibration (30 V dc and Above).....	3-6
	AC Volts Calibration (NORMAL Output).....	3-7
	Thermocouple Function Calibration.....	3-8
	DC Current Calibration .....	3-10
	AC Current Calibration .....	3-11
	DC Volts Calibration (AUX Output).....	3-17
	AC Volts Calibration (AUX Output).....	3-17
	Resistance Calibration .....	3-18
	Capacitance Calibration.....	3-21
	Calibration Remote Commands.....	3-24
	How to Make a Calibration Report.....	3-30
	Performance Verification Tests .....	3-31
	How to Zero the Calibrator.....	3-31
	DC Volts Verification (NORMAL Output).....	3-31
	DC Volts Verification (AUX Output) .....	3-32
	DC Current Verification .....	3-33
	Resistance Verification.....	3-34
	AC Voltage Verification (NORMAL Output).....	3-35
	AC Voltage Verification (AUX Output) .....	3-37
	AC Current Verification .....	3-38
	Capacitance Verification .....	3-41
	200 $\mu$ F to 110 mF Capacitance Verification .....	3-43
	Capacitance Measurement.....	3-43
	Measurement Uncertainty .....	3-47
	Thermocouple Simulation Verification (Sourcing).....	3-47
	Thermocouple Measurement Verification.....	3-48
	Phase Accuracy Verification, Volts and AUX Volts.....	3-48
	Phase Accuracy Verification, Volts and Current.....	3-49
	Frequency Accuracy Verification.....	3-50

<b>4</b>	<b>Maintenance.....</b>	<b>4-1</b>
	Introduction.....	4-3
	Access Procedure.....	4-3
	How to Remove Analog Modules.....	4-3
	How to Remove the Main CPU (A9).....	4-3
	How to Remove the Rear-Panel Assemblies.....	4-4
	How to Remove the Filter PCA (A12).....	4-4
	How to Remove the Encoder (A2) and Display PCAs.....	4-4
	How to Remove the Keyboard and Access the Output Block.....	4-4
	Diagnostic Tests.....	4-7
	How to Do Diagnostic Tests.....	4-7
	How to Test the Front Panel.....	4-7
	Complete List of Error Messages.....	4-8
<b>5</b>	<b>List of Replaceable Parts.....</b>	<b>5-1</b>
	Introduction.....	5-3
	How to Obtain Parts.....	5-3
<b>6</b>	<b>SC600 Calibration Option.....</b>	<b>6-1</b>
	Introduction.....	6-3
	Maintenance.....	6-3
	SC600 Specifications.....	6-3
	Voltage Function Specifications.....	6-4
	Edge Specifications.....	6-4
	Leveled Sine Wave Specifications.....	6-5
	Time Marker Specifications.....	6-5
	Wave Generator Specifications.....	6-5
	Pulse Generator Specifications.....	6-6
	Trigger Signal Specifications (Pulse Function).....	6-6
	Trigger Signal Specifications (Time Marker Function).....	6-6
	Trigger Signal Specifications (Edge Function).....	6-6
	Trigger Signal Specifications (Square Wave Voltage Function).....	6-6
	Trigger Signal Specifications.....	6-6
	Oscilloscope Input Resistance Measurement Specifications.....	6-6
	Oscilloscope Input Capacitance Measurement Specifications.....	6-6
	Overload Measurement Specifications.....	6-7
	Theory of Operation.....	6-7
	Voltage Mode.....	6-7
	Edge Mode.....	6-7
	Leveled Sine Wave Mode.....	6-7
	Time Marker Mode.....	6-7
	Wave Generator Mode.....	6-8
	Input Impedance Mode (Resistance).....	6-8
	Input Impedance Mode (Capacitance).....	6-8
	Overload Mode.....	6-8
	Equipment Necessary for SC600 Calibration and Verification.....	6-10
	Calibration Setup.....	6-13
	Calibration and Verification of Square Wave Voltage Functions.....	6-14
	Overview of HP3458A Operation.....	6-14
	Voltage Square Wave Measurement Setup.....	6-14
	Edge and Wave Gen Square Wave Measurements Setup.....	6-15
	DC Voltage Calibration.....	6-16
	AC Voltage Calibration.....	6-17
	Wave Generator Calibration.....	6-17

Edge Amplitude Calibration.....	6-18
Leveled Sine Wave Amplitude Calibration.....	6-18
Leveled Sine Wave Flatness Calibration.....	6-19
Low Frequency Calibration.....	6-20
High Frequency Calibration.....	6-20
Pulse Width Calibration.....	6-21
MeasZ Calibration.....	6-22
Verification.....	6-24
DC Voltage Verification.....	6-24
Verification at 1 M $\Omega$ .....	6-25
Verification at 50 $\Omega$ .....	6-25
AC Voltage Amplitude Verification.....	6-27
Verification at 1 M $\Omega$ .....	6-28
Verification at 50 $\Omega$ .....	6-29
AC Voltage Frequency Verification.....	6-30
Edge Amplitude Verification.....	6-31
Edge Frequency Verification.....	6-32
Edge Duty Cycle Verification.....	6-33
Edge Rise Time Verification.....	6-33
Edged Aberration Verification.....	6-35
Tunnel Diode Pulser Drive Amplitude Verification.....	6-36
Leveled Sine Wave Amplitude Verification.....	6-36
Leveled Sine Wave Frequency Verification.....	6-38
Leveled Sine Wave Harmonics Verification.....	6-38
Leveled Sine Wave Flatness Verification.....	6-40
Equipment Setup for Low Frequency Flatness.....	6-41
Equipment Setup for High Frequency Flatness.....	6-41
Low Frequency Verification.....	6-42
High Frequency Verification.....	6-43
Time Marker Verification.....	6-44
Wave Generator Verification.....	6-45
Wave Generator Verification Setup.....	6-46
Verification at 1 M $\Omega$ .....	6-46
Verification at 50 $\Omega$ .....	6-47
Pulse Width Verification.....	6-49
Pulse Period Verification.....	6-50
MeasZ Resistance Verification.....	6-51
MeasZ Capacitance Verification.....	6-52
Overload Function Verification.....	6-53
SC600 Hardware Adjustments.....	6-54
Necessary Equipment.....	6-54
How to Adjust the Leveled Sine Wave Function.....	6-54
Equipment Setup.....	6-54
How to Adjust the Leveled Sine Wave VCO Balance.....	6-55
How to Adjust the Leveled Sine Wave Harmonics.....	6-55
How to Adjust the Aberrations for the Edge Function.....	6-56
Equipment Setup.....	6-56
How to Adjust the Edge Aberrations.....	6-57
<b>7 SC1100 Calibration Option.....</b>	<b>7-1</b>
Introduction.....	7-3
Maintenance.....	7-3
SC1100 Specifications.....	7-3
Volt Specifications.....	7-4
Edge Specifications.....	7-5

Leveled Sine Wave Specifications .....	7-6
Time Marker Specifications .....	7-7
Wave Generator Specifications .....	7-7
Pulse Generator Specifications .....	7-8
Trigger Signal Specifications (Pulse Function) .....	7-8
Trigger Signal Specifications (Time Marker Function) .....	7-8
Trigger Signal Specifications (Edge Function) .....	7-8
Trigger Signal Specifications (Square Wave Voltage Function) .....	7-8
TV Trigger Signal Specifications .....	7-8
Oscilloscope Input Resistance Measurement Specifications .....	7-9
Oscilloscope Input Capacitance Measurement Specifications .....	7-9
Overload Measurement Specifications .....	7-9
Theory of Operation .....	7-9
Voltage Mode .....	7-9
Edge Mode .....	7-9
Leveled Sine Wave Mode .....	7-9
Time Marker Mode .....	7-9
Wave Generator Mode .....	7-10
Pulse Generator Modes .....	7-10
Input Impedance Mode (Resistance) .....	7-10
Input Impedance Mode (Capacitance) .....	7-10
Overload Mode .....	7-10
Equipment Necessary for SC1100 Calibration and Verification .....	7-12
SC1100 Calibration Setup .....	7-15
Calibration and Verification of Square Wave Voltage Functions .....	7-16
Overview of HP3458A Operation .....	7-16
Voltage Square Wave Measurement Setup .....	7-16
Edge and Wave Gen Square Wave Measurements Setup .....	7-17
DC Voltage Calibration .....	7-18
AC Voltage Calibration .....	7-19
Wave Generator Calibration .....	7-19
Edge Amplitude Calibration .....	7-20
Leveled Sine Wave Amplitude Calibration .....	7-20
Leveled Sine Wave Flatness Calibration .....	7-21
Low Frequency Calibration .....	7-22
High Frequency Calibration .....	7-22
Pulse Width Calibration .....	7-23
MeasZ Calibration .....	7-24
Verification .....	7-26
DC Voltage Verification .....	7-26
Verification at 1 M $\Omega$ .....	7-27
Verification at 50 $\Omega$ .....	7-27
AC Voltage Amplitude Verification .....	7-29
Verification at 1 M $\Omega$ .....	7-30
Verification at 50 $\Omega$ .....	7-31
AC Voltage Frequency Verification .....	7-32
Edge Amplitude Verification .....	7-33
Edge Frequency Verification .....	7-34
Edge Duty Cycle Verification .....	7-35
Edge Rise Time Verification .....	7-35
Edged Aberration Verification .....	7-37
Tunnel Diode Pulser Drive Amplitude Verification .....	7-38
Leveled Sine Wave Amplitude Verification .....	7-39
Leveled Sine Wave Frequency Verification .....	7-40
Leveled Sine Wave Harmonics Verification .....	7-41

Leveled Sine Wave Flatness Verification .....	7-43
Equipment Setup for Low Frequency Flatness .....	7-43
Equipment Setup for High Frequency Flatness.....	7-44
Low Frequency Verification .....	7-45
High Frequency Verification.....	7-46
Time Marker Verification.....	7-57
Wave Generator Verification.....	7-58
Wave Generator Verification Setup .....	7-58
Verification at 1 M $\Omega$ .....	7-58
Verification at 50 $\Omega$ .....	7-59
Pulse Width Verification .....	7-62
Pulse Period Verification.....	7-63
MeasZ Resistance Verification.....	7-63
MeasZ Capacitance Verification .....	7-64
Overload Function Verification.....	7-65
SC1100 Hardware Adjustments.....	7-66
Necessary Equipment .....	7-66
How to Adjust the Leveled Sine Wave Function .....	7-67
Equipment Setup .....	7-67
How to Adjust the Leveled Sine Wave VCO Balance.....	7-67
How to Adjust the Leveled Sine Wave Harmonics.....	7-68
How to Adjust the Aberrations for the Edge Function .....	7-69
Equipment Setup .....	7-69
How to Adjust the Edge Aberrations .....	7-70

## **8 PQ Calibration Option ..... 8-1**

Introduction.....	8-3
PQ Options Specifications .....	8-3
Composite Harmonic Function Specifications .....	8-3
AC Voltage Specifications .....	8-4
AC Voltage Auxiliary Specifications (Dual Output Mode Only) .....	8-5
AC Current Specifications, LCOMP OFF.....	8-5
AC Current Specifications, LCOMP OFF (continued) .....	8-6
AC Current Specifications, LCOMP ON* .....	8-6
Flicker Simulation Mode.....	8-7
Sags & Swells Simulation Mode.....	8-7
Phase Specifications, Sinewave Outputs .....	8-7
Theory of Operation.....	8-7
DDS Assembly (A6).....	8-8
Main CPU Assembly (A9) .....	8-8
Maintenance.....	8-8
Equipment Necessary for PQ Option Calibration and Verification.....	8-8
Performance Verification Tests .....	8-9
Delta Amplitude Verification .....	8-9
Composite Harmonics Verification.....	8-10
Calibration .....	8-20
Normal AC Voltage.....	8-21
AUX AC Current.....	8-21
AUX AC Voltage .....	8-22

# List of Tables

Table	Title	Page
1-1.	Symbols.....	1-4
3-1.	Consolidated List of Required Equipment for Calibration and Verification .....	3-3
3-2.	Test Equipment Required for DC Volts Calibration .....	3-5
3-3.	Calibration Steps for DC Volts .....	3-6
3-4.	Test Equipment Necessary for AC Volts Calibration .....	3-7
3-5.	AC Volts Calibration Steps .....	3-7
3-6.	Test Equipment Necessary for Thermocouple Function Calibration .....	3-8
3-7.	Thermocouple Measurement Calibration Steps .....	3-9
3-8.	Test Equipment Necessary for DC Current Calibration.....	3-10
3-9.	DC Current Calibration Steps .....	3-11
3-10.	Test Equipment Necessary for AC Current Calibration.....	3-13
3-11.	AC Current Calibration Steps .....	3-13
3-12.	AUX DC Volts Calibration Steps .....	3-17
3-13.	AUX Output AC Volts Calibration Steps .....	3-17
3-14.	Test Equipment Necessary for Resistance Calibration .....	3-18
3-15.	Resistance Calibration Steps .....	3-19
3-16.	Test Equipment Necessary for Capacitance Calibration.....	3-21
3-17.	Capacitance Calibration Steps.....	3-22
3-18.	Calibration Entry Points in Remote .....	3-24
3-19.	Verification Tests for DC Voltage (NORMAL Output) .....	3-31
3-20.	Verification Tests for DC Voltage (AUX Output).....	3-32
3-21.	Shunt Values for DC Current Calibration and Verification .....	3-33
3-22.	Verification Tests for DC Current (AUX Output) .....	3-33
3-23.	Verification Tests for Resistance .....	3-34
3-24.	Verification Tests for AC Voltage (NORMAL Output) .....	3-35
3-25.	Verification Tests for AC Voltage (AUX Output).....	3-37
3-26.	Shunt Values for AC Current Verification.....	3-38
3-27.	Verification Tests for AC Current.....	3-39
3-28.	Verification Tests for Capacitance.....	3-42
3-29.	Necessary Test Equipment for High-Value Capacitance Measurements.....	3-43
3-30.	Verification Tests for Thermocouple Simulation.....	3-47
3-31.	Verification Tests for Thermocouple Measurement .....	3-48
3-32.	Verification Tests for Phase Accuracy, V and V .....	3-48
3-33.	Verification Tests for Phase Accuracy, V and I.....	3-49
3-34.	Verification Tests for Frequency.....	3-50

4-1.	Error Message Format.....	4-8
5-1.	Front-Panel Assembly.....	5-4
5-2.	Front-Panel Assembly (Rear View).....	5-7
5-3.	Rear-Panel Assembly.....	5-9
5-4.	Chassis Assembly.....	5-12
5-5.	Wiring.....	5-14
5-6.	Final Assembly.....	5-16
6-1.	SC600 Calibration and Verification Equipment.....	6-10
6-2.	Voltage HP3458A Settings.....	6-14
6-3.	Edge and Wave Generator HP3458A Settings.....	6-15
6-4.	Verification Methods for SC600 Functions.....	6-24
6-5.	DC Voltage Verification at 1 M $\Omega$ .....	6-25
6-6.	DC Voltage Verification at 50 $\Omega$ .....	6-27
6-7.	AC Voltage Verification at 1 M $\Omega$ .....	6-28
6-8.	AC Voltage Verification at 50 $\Omega$ .....	6-30
6-9.	AC Voltage Frequency Verification.....	6-31
6-10.	Edge Amplification Verification.....	6-32
6-11.	Edge Frequency Verification.....	6-32
6-12.	Edge Rise Time Verification.....	6-35
6-13.	Edge Aberrations.....	6-36
6-14.	Tunnel Diode Pulser Amplitude Verification.....	6-36
6-15.	Leveled Sine Wave Amplitude Verification.....	6-37
6-16.	Leveled Sine Wave Frequency Verification.....	6-38
6-17.	Leveled Sine Wave Harmonics Verification.....	6-39
6-18.	Low Frequency Flatness Verification at 5.5 V.....	6-43
6-19.	High Frequency Flatness Verification at 5.5 V.....	6-44
6-20.	Time Marker Verification.....	6-45
6-21.	Wave Generator Verification at 1 M $\Omega$ .....	6-47
6-22.	Wave Generator Verification at 50 $\Omega$ .....	6-48
6-23.	Pulse Width Verification.....	6-50
6-24.	Pulse Period Verification.....	6-51
6-25.	MeasZ Resistance Verification.....	6-52
6-26.	MeasZ Capacitance Verification.....	6-53
7-1.	SC600 Calibration and Verification Equipment.....	7-12
7-2.	Voltage HP3458A Settings.....	7-16
7-3.	Edge and Wave Generator HP3458A Settings.....	7-17
7-4.	Verification Methods for SC1100 Functions.....	7-26
7-5.	DC Voltage Verification at 1 M $\Omega$ .....	7-27
7-6.	DC Voltage Verification at 50 $\Omega$ .....	7-29
7-7.	AC Voltage Verification at 1 M $\Omega$ .....	7-30
7-8.	AC Voltage Verification at 50 $\Omega$ .....	7-32
7-9.	AC Voltage Frequency Verification.....	7-33
7-10.	Edge Amplification Verification.....	7-34
7-11.	Edge Frequency Verification.....	7-34
7-12.	Edge Rise Time Verification.....	7-37
7-13.	Edge Aberrations.....	7-38
7-14.	Tunnel Diode Pulser Amplitude Verification.....	7-39
7-15.	Leveled Sine Wave Amplitude Verification.....	7-40
7-16.	Leveled Sine Wave Frequency Verification.....	7-41
7-17.	Leveled Sine Wave Harmonics Verification.....	7-42
7-18.	Low Frequency Flatness Verification at 5.5 V.....	7-46
7-19.	High Frequency Flatness Verification.....	7-48
7-20.	Time Marker Verification.....	7-57
7-21.	Wave Generator Verification at 1 M $\Omega$ .....	7-59
7-22.	Wave Generator Verification at 50 $\Omega$ .....	7-61

---

7-23. Pulse Width Verification.....	7-63
7-24. Pulse Period Verification .....	7-63
7-25. MeasZ Resistance Verification .....	7-64
7-26. MeasZ Capacitance Verification.....	7-65
8-1. SC600 Calibration and Verification Equipment .....	8-8
8-2. Delta Amplitude Verification, Static Condition.....	8-9
8-3. Delta Amplitude Verification, Flicker Condition.....	8-10
8-4. Composite Harmonics Verification.....	8-10
8-5. Normal AC Volts .....	8-21
8-6. AUX AC Current .....	8-21
8-7. AUX AC Voltage.....	8-22



# List of Figures

Figure	Title	Page
1-1.	5522A Multi-Product Calibrator .....	1-3
1-2.	RS-232 Remote Connection.....	1-6
2-1.	5522A Internal Layout .....	2-3
2-2.	Synthesized Resistance Function .....	2-4
2-3.	Synthesized Capacitance Function.....	2-5
2-4.	Current Function (AUX Out Ranges) .....	2-6
2-5.	Voltage Function.....	2-7
3-1.	DC Volts Calibration Connections up to 30 V.....	3-6
3-2.	DC Volts 30 V and Above Calibration Connections .....	3-7
3-3.	AC Volts Calibration Connections.....	3-8
3-4.	Thermocouple Source Calibration Connections.....	3-9
3-5.	Thermocouple Measure Calibration Connections.....	3-10
3-6.	DC Current Calibration Connections .....	3-11
3-7.	AC Current Calibration with Fluke A40 Shunt Connections.....	3-12
3-8.	AC Current Calibration with Fluke A40A Shunt Connection .....	3-14
3-9.	Sample MET/CAL Program.....	3-15
3-10.	4-Wire Resistance Connection.....	3-20
3-11.	Scaling the DMM to a Fluke 742A .....	3-20
3-12.	2-Wire Resistance Connection.....	3-21
3-13.	Scaling the DMM to a Guideline 9334 .....	3-21
3-14.	Capacitance Calibration Connection.....	3-23
3-15.	Normal Volts and AUX Volts Phase Verification Connection.....	3-23
3-16.	Volts and Current Phase Verification Connection .....	3-24
3-17.	AC Current Verification Connections with a Metal Film Resistor (3.299 mA and Lower).....	3-39
3-18.	High-Value Capacitance Measurement Setup.....	3-45
3-19.	Example Visual Basic Program.....	3-46
4-1.	Exploded View of Rear-Panel Assemblies .....	4-5
4-2.	Exploded View of Front-Panel Assemblies .....	4-6
5-1.	Front Panel Assembly .....	5-6
5-2.	Front-Panel Assembly (rear view) .....	5-8
5-3.	Rear-Panel Assembly .....	5-11
5-4.	Chassis Assembly.....	5-13
5-5.	Wiring Diagram .....	5-15
5-6.	Final Assembly.....	5-17

6-1.	Error Message for Scope Option.....	6-3
6-2.	SC600 Block Diagram .....	6-9
6-3.	Equipment Setup for SC600 Voltage Square Wave Measurements .....	6-15
6-4.	Equipment Setup for SC600 Edge and Wave Gen Square Wave Measurements ..	6-16
6-5.	Calibrator to 5790A AC Measurement Standard Connections .....	6-19
6-6.	MeasZ Calibration Connections.....	6-23
6-7.	AC Voltage Frequency Verification Setup .....	6-30
6-8.	Edge Rise Time Verification Setup.....	6-34
6-9.	Edge Rise Time.....	6-35
6-10.	Leveled Sine Wave Harmonics Verification Setup.....	6-39
6-11.	Calibrator to 5790A Measurement Standard Connections.....	6-41
6-12.	HP 437B Power Meter to the HP 8482A or 8481D Power Sensor Connections ...	6-42
6-13.	Calibrator to the HP Power Meter and Power Sensor Connections .....	6-42
6-14.	Wave Generator Verification Connections .....	6-46
6-15.	Overload Function Verification Connections.....	6-53
6-16.	Leveled Sine Wave Balance Adjustment.....	6-55
6-17.	Leveled Sine Wave Harmonics Adjustment .....	6-56
6-18.	Edge Aberrations Adjustment.....	6-58
7-1.	Error Message for Scope Option.....	7-3
7-2.	SC1100 Block Diagram .....	7-11
7-3.	Equipment Setup for SC1100 Voltage Square Wave Measurements .....	7-17
7-4.	Equipment Setup for SC1100 Edge and Wave Gen Square Wave Measurement..	7-18
7-5.	Calibrator to 5790A AC Measurement Standard Connections .....	7-21
7-6.	MeasZ Calibration Connections.....	7-25
7-7.	AC Voltage Frequency Verification Setup .....	7-32
7-8.	Edge Rise Time Verification Setup.....	7-36
7-9.	Edge Rise Time.....	7-37
7-10.	Leveled Sine Wave Harmonics Verification Setup.....	7-41
7-11.	Calibrator to 5790A Measurement Standard Connections.....	7-44
7-12.	HP 437B Power Meter to the HP 8482A or 8481D Power Sensor Connections ...	7-45
7-13.	Calibrator to the HP Power Meter and Power Sensor Connections .....	7-45
7-14.	Wave Generator Verification Connections .....	7-58
7-15.	Overload Function Verification Connections.....	7-66
7-16.	Leveled Sine Wave Balance Adjustment.....	7-68
7-17.	Leveled Sine Wave Harmonics Adjustment .....	7-69
7-18.	Edge Aberrations Adjustment.....	7-71

# Chapter 1

## Introduction and Specifications

Title	Page
Introduction.....	1-3
Safety Information .....	1-4
Overload Protection .....	1-5
Operation Overview.....	1-5
Local Operation .....	1-6
Remote Operation (RS-232).....	1-6
Remote Operation (IEEE-488).....	1-7
Service Information .....	1-7
How to Contact Fluke Calibration .....	1-7
General Specifications .....	1-8
Detailed Specifications .....	1-9
DC Voltage.....	1-9
DC Current .....	1-10
Resistance.....	1-12
AC Voltage (Sine Wave).....	1-13
AC Current (Sine Wave) .....	1-15
Capacitance.....	1-17
Temperature Calibration (Thermocouple).....	1-18
Temperature Calibration (RTD).....	1-19
DC Power Specification Summary.....	1-20
AC Power (45 Hz to 65 Hz) Specification Summary, PF=1 .....	1-20
Power and Dual Output Limit Specifications.....	1-20
Phase.....	1-21
Additional Specifications.....	1-22
Frequency .....	1-22
Harmonics (2 <sup>nd</sup> to 50 <sup>th</sup> ) .....	1-22
AC Voltage (Sine Wave) Extended Bandwidth .....	1-23
AC Voltage (Non-Sine Wave).....	1-24
AC Voltage, DC Offset .....	1-26
AC Voltage, Square Wave Characteristics.....	1-26
AC Voltage, Triangle Wave Characteristics (typical).....	1-26
AC Current (Non-Sine Wave).....	1-27
AC Current, Square Wave Characteristics (typical).....	1-28
AC Current, Triangle Wave Characteristics (typical) .....	1-28



## Introduction

### **⚠️⚠️ Warning**

**To prevent possible electrical shock, fire, or personal injury, read all safety information before you use the Product.**

The 5522A Calibrator (the Product or the Calibrator), shown in Figure 1-1 is a fully programmable precision source for:

- DC voltage from 0 V to  $\pm 1020$  V.
- AC voltage from 1 mV to 1020 V, with output from 10 Hz to 500 kHz.
- AC current from 29  $\mu$ A to 20.5 A, with variable frequency limits.
- DC current from 0 to  $\pm 20.5$  A.
- Resistance values from a short circuit to 1100 M $\Omega$ .
- Capacitance values from 220 pF to 110 mF.
- Simulated output for eight types of Resistance Temperature Detectors (RTDs).
- Simulated output for eleven types of thermocouples.

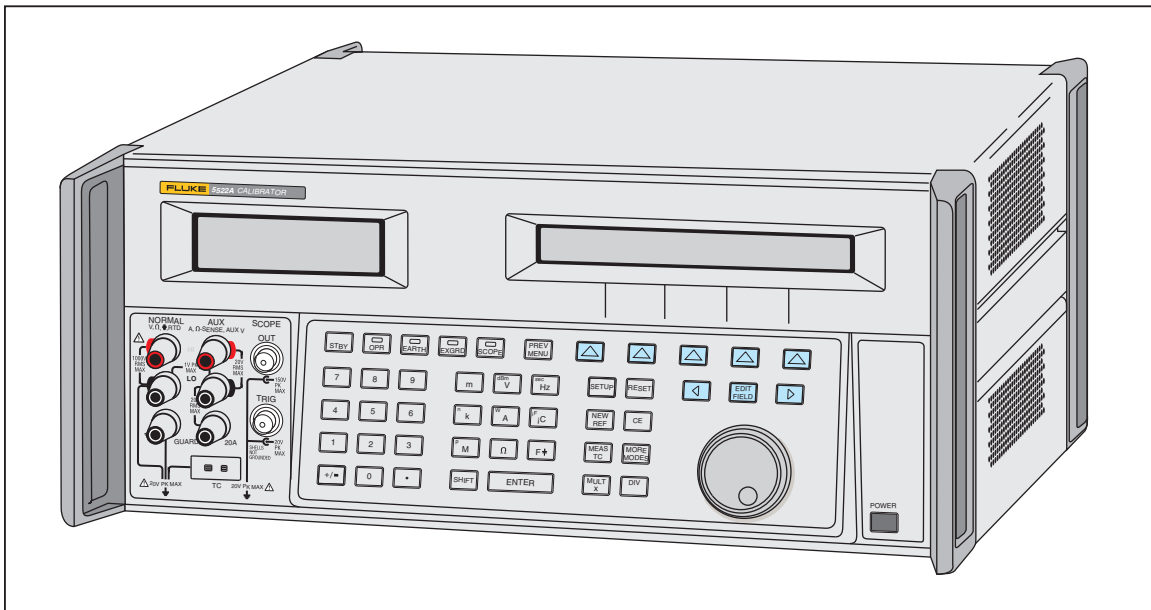

**Figure 1-1. 5522A Multi-Product Calibrator**

gjh001.eps

Features of the Calibrator include:

- Calculates meter errors automatically, with user selectable reference values.
- **MULT** and **DIV** keys that change the output value to pre-determined cardinal values for various functions.
- Programmable entry limits that prevent operator entries that are more than preset output limits.
- Output of voltage and current at the same time, to a maximum equivalent of 20.9 kW.
- Pressure measurement when used with Fluke 700 Series pressure modules.
- 10 MHz reference input and output. Use this to input a high-accuracy 10 MHz

reference to transfer the frequency accuracy to the 5522A, or have one or more Calibrators that are synchronized to a master 5522A.

- Output of two voltages at the same time.
- Extended bandwidth mode outputs multiple waveforms down to 0.01 Hz, and sine waves to 2 MHz.
- Variable phase signal output.
- Standard IEEE-488 (GPIB) interface, that complies with ANSI/IEEE Standards 488.1-1987 and 488.2-1987.
- EIA Standard RS-232 serial data interface to print or transfer internally stored calibration constants, and for remote control of the 5522A.
- Pass-through RS-232 serial data interface to communicate with the Unit Under Test (UUT).

## Safety Information





This Calibrator complies with:

- ANSI/ISA-61010-1 (82.02.01)
- CAN/CSA C22.2 No. 61010-1-04
- ANSI/UL 61010-1:2004
- EN 61010-1:2001

A **Warning** identifies conditions and procedures that are dangerous to the user. A **Caution** identifies conditions and procedures that can cause damage to the Product or the equipment under test.

Symbols used in this manual and on the Product are explained in Table 1-1.

Table 1-1. Symbols

Symbol	Description	Symbol	Description
CAT I	IEC Measurement Category I – CAT I is for measurements not directly connected to mains. Maximum transient Overvoltage is as specified by terminal markings.		Conforms to relevant North American Safety Standards.
CE	Conforms to European Union directives		Do not dispose of this product as unsorted municipal waste. Go to Fluke's website for recycling information.
	Rick of Danger. Important information. See manual.		Hazardous voltage

### Warning

To prevent possible electrical shock, fire, or personal injury:

- **Read all safety Information before you use the Product.**
- **Do not use the Product if it operates incorrectly.**
- **Replace the mains power cord if the insulation is damaged or if the insulation shows signs of wear.**

- Do not touch voltages > 30 V ac rms, 42 V ac peak, or 60 V dc.
- Do not use the Product around explosive gas, vapor, or in damp or wet environments.
- Make sure the ground conductor in the mains power cord is connected to a protective earth ground. Disruption of the protective earth could put voltage on the chassis that could cause death.
- Use only the mains power cord and connector approved for the voltage and plug configuration in your country and rated for the Product.
- Use only cables with correct voltage ratings.
- Do not do internal servicing or adjustment on this Product unless someone who can give first aid and do resuscitation is with you.
- Do not touch exposed connections and components while power is on.
- Do not wear a grounded wrist strap while you do work on this Product. A grounded wrist strap increases the risk of current flow through the body.
- Do not wear metal accessories while you do work in this Product.
- Disconnect mains power before you remove protective panels or replace components.

## Overload Protection

The Calibrator supplies reverse-power protection, fast output disconnection, and/or fuse protection on the output terminals for all functions.

Reverse-power protection prevents damage to the calibrator from occasional, accidental, normal-mode, and common-mode overloads to a maximum of  $\pm 300$  V peak. It is not intended as protection against frequent (systematic and repeated) abuse. Such abuse will cause the Calibrator to fail.

For volts, ohms, capacitance, and thermocouple functions, there is fast output disconnection protection. This protection senses applied voltages higher than 20 volts on the output terminals. It quickly disconnects the internal circuits from the output terminals and resets the calibrator when such overloads occur.

For current and aux voltage functions, user replaceable fuses supply protection from overloads applied to the Current/Aux Voltage output terminals. The fuses are accessed by an access door on the bottom of the calibrator. You must use replacement fuses of the same capacity and type specified in this manual, or the protection supplied by the Calibrator will be compromised.

## Operation Overview

The Calibrator can be operated at the front panel in the local mode, or remotely through the RS-232 or IEEE-488 ports. For remote operations, there are a number of software options available to integrate 5522A operation into a wide variety of calibration requirements.

### **Local Operation**

Typical local operations include front panel connections to the Unit Under Test (UUT), and then manual keystroke entries at the front panel to set the output mode of the Calibrator. You can review Calibrator specifications at the push of two buttons. The backlit liquid crystal display is easy to see from many different angles and light conditions. The large, easy-to-read keys are color-coded and supply tactile feedback.

### **Remote Operation (RS-232)**

There are two rear-panel serial data RS-232 ports: SERIAL 1 FROM HOST, and SERIAL 2 TO UUT (see Figure 1-2). Each port is dedicated to serial data communications to operate and control the 5522A when you do calibration procedures. For complete information on remote operations, see Chapter 5 of the *5522A Operators Manual*.

The SERIAL 1 FROM HOST serial data port connects a host terminal or personal computer to the Calibrator. You can send remote commands to the Calibrator from a terminal (or a PC running a terminal program), a BASIC program you write, or an optional Windows-based software such as 5500/CAL or MET/CAL. The 5500/CAL Software includes more than 200 example procedures that include a wide range of test tools the 5522A can calibrate. (See Chapter 6 of the *5522A Operators Manual* for a discussion of the RS-232 commands.)

The SERIAL 2 TO UUT serial data port connects a UUT to a PC or terminal through the 5522A (see Figure 1-2). This “pass-through” configuration removes the requirement for two COM ports at the PC or terminal. A set of four commands control the operation of the SERIAL 2 TO UUT serial port. See Chapter 6 of the *5522A Operators Manual* for a discussion of the UUT\_\* commands. The SERIAL 2 TO UUT port is also used to connect to the Fluke 700 Series Pressure Modules.

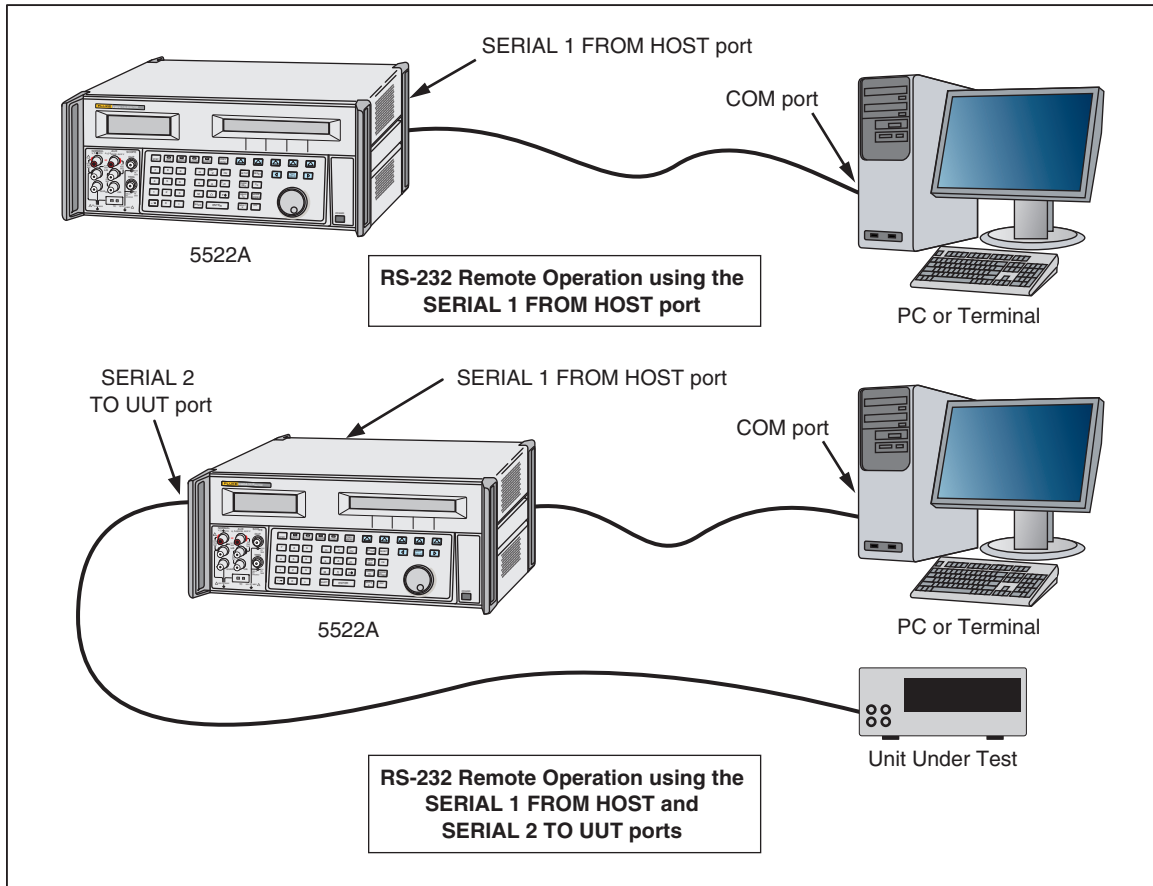

Figure 1-2. RS-232 Remote Connection

gjh002.eps

### Remote Operation (IEEE-488)

The rear panel IEEE-488 port is a fully programmable parallel interface bus that operates to IEEE-488.1 and IEEE-488.2 (supplement) standards. When controlled remotely by an instrument controller, the Calibrator operates exclusively as a “talker/listener.” You can write your own programs with commands from the IEEE-488 command set or run the optional Windows-based MET/CAL software. (See Chapter 6 of the *5522A Operators Manual* for a discussion of the commands available for IEEE-488 operation.)

### Service Information

If you have a problem with the Calibrator in the 1-year warranty period, send it to a Fluke Service Center for warranty repair. For out of warranty repair, get in touch with a Fluke Service Center for a cost estimate.

This service manual gives instructions for verification of performance, calibration, and maintenance. If you choose to repair a malfunction, information in this manual can help you find which module (printed circuit assembly) has a fault.

### How to Contact Fluke Calibration

To contact Fluke Calibration, call one of the following telephone numbers:

- Technical Support USA: 1-877-355-3225
- Calibration/Repair USA: 1-877-355-3225
- Canada: 1-800-36-FLUKE (1-800-363-5853)

- Europe: +31-40-2675-200
- Japan: +81-3-6714-3114
- Singapore: +65-6799-5566
- China: +86-400-810-3435
- Brazil: +55-11-3759-7600
- Anywhere in the world: +1-425-446-6110

To see product information and download the latest manual supplements, visit Fluke Calibration’s website at [www.flukecal.com](http://www.flukecal.com).

To register your product, visit <http://flukecal.com/register-product>.

## General Specifications

The following tables list the 5522A specifications. All specifications are valid after allowing a warm-up period of 30 minutes, or twice the time the 5522A has been turned off. (For example, if the 5522A has been turned off for 5 minutes, the warm-up period is 10 minutes.)

All specifications apply for the temperature and time period indicated. For temperatures outside of  $t_{cal} \pm 5\text{ }^{\circ}\text{C}$  ( $t_{cal}$  is the ambient temperature when the 5522A was calibrated), the temperature coefficient as stated in the General Specifications must be applied.

The specifications also assume the Calibrator is zeroed every seven days or whenever the ambient temperature changes more than  $5\text{ }^{\circ}\text{C}$ . The tightest ohms specifications are maintained with a zero cal every 12 hours within  $\pm 1\text{ }^{\circ}\text{C}$  of use.

Also see additional specifications later in this chapter for information on extended specifications for ac voltage and current.

<b>Warmup Time</b> .....	Twice the time since last warmed up, to a maximum of 30 minutes.
<b>Settling Time</b> .....	Less than 5 seconds for all functions and ranges except as noted.
<b>Standard Interfaces</b> .....	IEEE-488 (GPIB), RS-232
<b>Temperature</b>	
Operating .....	$0\text{ }^{\circ}\text{C}$ to $50\text{ }^{\circ}\text{C}$
Calibration ( $t_{cal}$ ).....	$15\text{ }^{\circ}\text{C}$ to $35\text{ }^{\circ}\text{C}$
Storage .....	$-20\text{ }^{\circ}$ to $+70\text{ }^{\circ}\text{C}$ ; The DC current ranges 0 to 1.09999 A and 1.1 A to 2.99999 A are sensitive to storage temperatures above $50\text{ }^{\circ}\text{C}$ . If the 5522A is stored above $50\text{ }^{\circ}\text{C}$ for greater than 30 minutes, these ranges must be re-calibrated. Otherwise, the 90 day and 1 year uncertainties of these ranges double.
<b>Temperature Coefficient</b> .....	Temperature coefficient for temperatures outside $t_{cal} +5\text{ }^{\circ}\text{C}$ is $0.1/X/^{\circ}\text{C}$ of the 90-day specification (or 1-year, as applicable) per $^{\circ}\text{C}$
<b>Relative Humidity</b>	
Operating .....	$<80\text{ }%$ to $30\text{ }^{\circ}\text{C}$ , $<70\text{ }%$ to $40\text{ }^{\circ}\text{C}$ , $<40\text{ }%$ to $50\text{ }^{\circ}\text{C}$
Storage .....	$<95\text{ }%$ , non-condensing. After long periods of storage at high humidity, a drying-out period (with power on) of at least one week may be required.
<b>Altitude</b>	
Operating .....	3,050 m (10,000 ft) maximum
Non-operating .....	12,200 m (40,000 ft) maximum
<b>Safety</b> .....	Complies with EN/IEC 61010-1:2001, CAN/CSA-C22.2 No. 61010-1-04, ANSI/UL 61010-1:2004;
<b>Output Terminal Electrical Overload Protection</b>	Provides reverse-power protection, immediate output disconnection, and/or fuse protection on the output terminals for all functions. This protection is for applied external voltages up to $\pm 300\text{ V}$ peak.
<b>Analog Low Isolation</b> .....	20 V normal operation, 400 V peak transient
<b>EMC</b> .....	Complies with EN/IEC 61326-1:2006, EN/IEC 61326-2-1:2006 for controlled EM environments under the following conditions. If used in areas with Electromagnetic fields of 1 to 3 V/m from 0.08-1GHz, resistance outputs have a floor adder of $0.508\text{ }\Omega$ Performance not specified above 3 V/m. This instrument may be susceptible to electro-static discharge (ESD) to the binding posts. Good static awareness

practices should be followed when handling this and other pieces of electronic equipment. Additionally this instrument may be susceptible to electrical fast transients on the mains terminals. If any disturbances in operation are observed, it is recommended that the rear panel chassis ground terminal be connected to a known good earth ground with a low inductance ground strap. Note that a mains power outlet while providing a suitable ground for protection against electric shock hazard may not provide an adequate ground to properly drain away conducted rf disturbances and may in fact be the source of the disturbance. This instrument was certified for EMC performance with data I/O cables not in excess of 3m.

<b>Line Power</b> .....	Line Voltage (selectable): 100 V, 120 V, 220 V, 240 V Line Frequency: 47 Hz to 63 Hz Line Voltage Variation: $\pm 10\%$ about line voltage setting For optimal performance at full dual outputs (e.g. 1000 V, 20 A) choose a line voltage setting that is $\pm 7.5\%$ from nominal.
<b>Power Consumption</b> .....	600 VA
Dimensions (HxWxL).....	17.8 cm x 43.2 cm x 47.3 cm (7 in x 17 in x 18.6 in) Standard rack width and rack increment, plus 1.5 cm (0.6 in) for feet on bottom of unit.
Weight (without options).....	22 kg (49 lb)
<b>Absolute Uncertainty Definition</b> .....	The 5522A specifications include stability, temperature coefficient, linearity, line and load regulation, and the traceability of the external standards used for calibration. You do not need to add anything to determine the total specification of the 5522A for the temperature range indicated.
<b>Specification Confidence Level</b> .....	99 %

## Detailed Specifications

### DC Voltage

Range	Absolute Uncertainty, tcal $\pm 5^\circ\text{C}$ $\pm(\text{ppm of output} + \mu\text{V})$		Stability	Resolution $\mu\text{V}$	Max Burden <sup>[1]</sup>
	90 days	1 year	24 hours, $\pm 1^\circ\text{C}$ $\pm(\text{ppm of output} + \mu\text{V})$		
0 to 329.9999 mV	15 + 1	20 + 1	3 + 1	0.1	65 $\Omega$
0 to 3.299999 V	9 + 2	11 + 2	2 + 1.5	1	10 mA
0 to 32.99999 V	10 + 20	12 + 20	2 + 15	10	10 mA
30 to 329.9999 V	15 + 150	18 + 150	2.5 + 100	100	5 mA
100 to 1020.000 V	15 + 1500	18 + 1500	3 + 300	1000	5 mA
<b>Auxiliary Output (dual output mode only) <sup>[2]</sup></b>					
0 to 329.9999 mV	300 + 350	400 + 350	30 + 100	1	5 mA
0.33 to 3.299999 V	300 + 350	400 + 350	30 + 100	10	5 mA
3.3 to 7 V	300 + 350	400 + 350	30 + 100	100	5 mA
<b>TC Simulate and Measure in Linear 10 <math>\mu\text{V}/^\circ\text{C}</math> and 1 <math>\text{mV}/^\circ\text{C}</math> modes <sup>[3]</sup></b>					
0 to 329.9999 mV	40 + 3	50 + 3	5 + 2	0.1	10 $\Omega$
<p>[1] Remote sensing is not provided. Output resistance is <math>&lt; 5\text{ m}\Omega</math> for outputs <math>\geq 0.33\text{ V}</math>. The AUX output has an output resistance of <math>&lt; 1\text{ }\Omega</math>. TC simulation has an output impedance of <math>10\text{ }\Omega \pm 1\text{ }\Omega</math>.</p> <p>[2] Two channels of dc voltage output are provided.</p> <p>[3] TC simulating and measuring are not specified for operation in electromagnetic fields above 0.4 v/m.</p>					

Range	Noise	
	Bandwidth 0.1 Hz to 10 Hz p-p $\pm(\text{ppm of output} + \text{floor})$	Bandwidth 10 Hz to 10 kHz rms
0 to 329.9999 mV	0 + 1 $\mu\text{V}$	6 $\mu\text{V}$
0 to 3.299999 V	0 + 10 $\mu\text{V}$	60 $\mu\text{V}$
0 to 32.99999 V	0 + 100 $\mu\text{V}$	600 $\mu\text{V}$
30 to 329.9999 V	10 + 1 mV	20 mV
100 to 1020.000 V	10 + 5 mV	20 mV

Auxiliary Output (dual output mode only) <sup>[1]</sup>		
0 to 329.9999 mV	0 + 5 $\mu$ V	20 $\mu$ V
0.33 to 3.299999 V	0 + 20 $\mu$ V	200 $\mu$ V
3.3 to 7 V	0 + 100 $\mu$ V	1000 $\mu$ V

[1] Two channels of dc voltage output are provided.

### DC Current

Range	Absolute Uncertainty, tcal $\pm 5$ °C $\pm$ (ppm of output + $\mu$ A)		Resolution	Max Compliance Voltage V	Max Inductive Load mH
	90 days	1 year			
0 to 329.999 $\mu$ A	120 + 0.02	150 + 0.02	1 nA	10	400
0 to 3.29999 mA	80 + 0.05	100 + 0.05	0.01 $\mu$ A	10	
0 to 32.9999 mA	80 + 0.25	100 + 0.25	0.1 $\mu$ A	7	
0 to 329.999 mA	80 + 2.5	100 + 2.5	1 $\mu$ A	7	
0 to 1.09999 A	160 + 40	200 + 40	10 $\mu$ A	6	
1.1 to 2.99999 A	300 + 40	380 + 40	10 $\mu$ A	6	
0 to 10.9999 A (20 A Range)	380 + 500	500 + 500	100 $\mu$ A	4	
11 to 20.5 A <sup>[1]</sup>	800 + 750 <sup>[2]</sup>	1000 + 750 <sup>[2]</sup>	100 $\mu$ A	4	

[1] Duty Cycle: Currents <11 A may be provided continuously. For currents >11 A, see Figure 1. The current may be provided Formula  $60 - T - I$  minutes any 60 minute period where T is the temperature in °C (room temperature is about 23 °C) and I is the output current in amperes. For example, 17 A, at 23 °C could be provided for  $60 - 23 - 17 = 20$  minutes each hour. When the 5522A is outputting currents between 5 and 11 amps for long periods, the internal self-heating reduces the duty cycle. Under those conditions, the allowable "on" time indicated by the formula and Figure 1 is achieved only after the 5522A is outputting currents <5 A for the "off" period first.

[2] Floor specification is 1500  $\mu$ A within 30 seconds of selecting operate. For operating times >30 seconds, the floor specification is 750  $\mu$ A.

Range	Noise	
	Bandwidth 0.1 Hz to 10 Hz p-p	Bandwidth 10 Hz to 10 kHz rms
0 to 329.999 $\mu$ A	2 nA	20 nA
0 to 3.29999 mA	20 nA	200 nA
0 to 32.9999 mA	200 nA	2.0 $\mu$ A
0 to 329.999 mA	2000 nA	20 $\mu$ A
0 to 2.99999 A	20 $\mu$ A	1 mA
0 to 20.5 A	200 $\mu$ A	10 mA

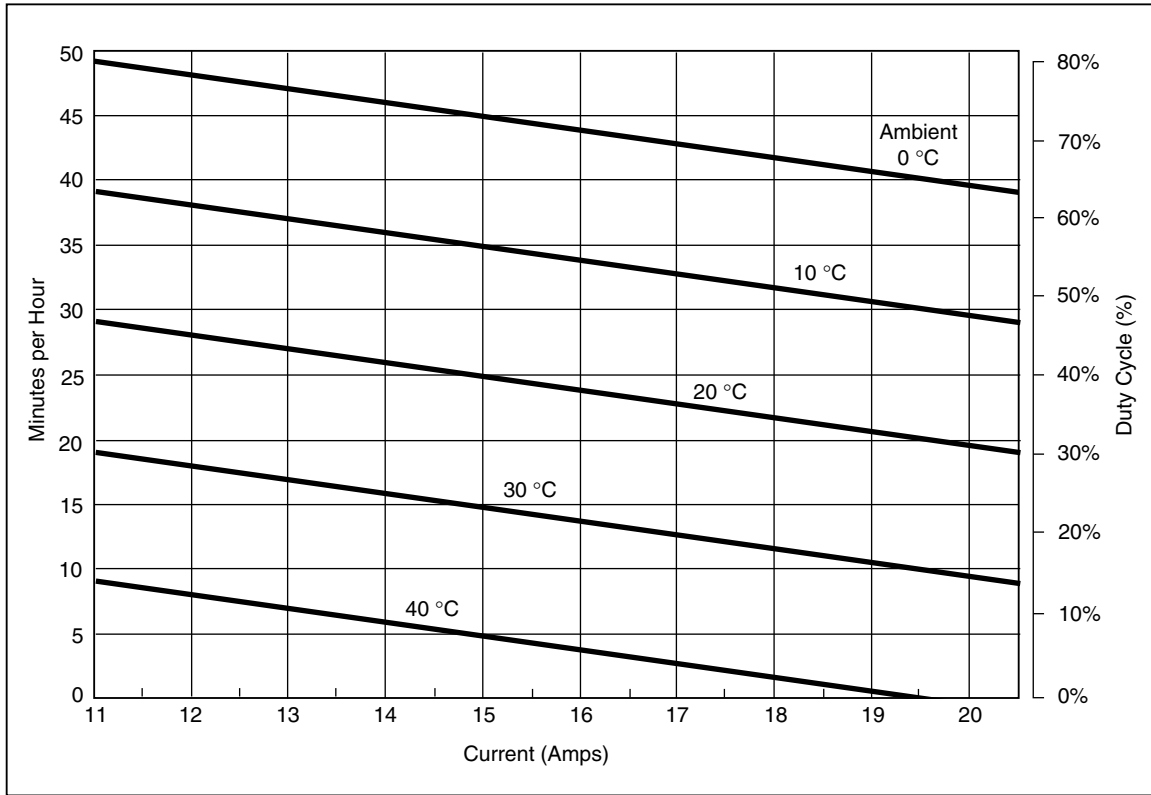

Figure 1. Allowable Duration of Current >11 A

## Resistance

Range <sup>[1]</sup>	Absolute Uncertainty, tcal ±5 °C ±(ppm of output +floor) <sup>[2]</sup>				Resolution Ω	Allowable Current <sup>[3]</sup>
	ppm of output		Floor (Ω) Time and temp since ohms zero cal			
	90 days	1 year	12 hrs ±1 °C	7 days ±5 °C		
0 to 10.9999 Ω	35	40	0.001	0.01	0.0001	1 mA to 125 mA
11 to 32.9999 Ω	25	30	0.0015	0.015	0.0001	1 mA to 125 mA
33 to 109.9999 Ω	22	28	0.0014	0.015	0.0001	1 mA to 70 mA
110 Ω to 329.9999 Ω	22	28	0.002	0.02	0.0001	1 mA to 40 mA
330 Ω to 1.099999 kΩ	22	28	0.002	0.02	0.001	1 mA to 18 mA
1.1 to 3.299999 kΩ	22	28	0.02	0.2	0.001	100 μA to 5 mA
3.3 to 10.99999 kΩ	22	28	0.02	0.1	0.01	100 μA to 1.8 mA
11 to 32.99999 kΩ	22	28	0.2	1	0.01	10 μA to 0.5 mA
33 to 109.9999 kΩ	22	28	0.2	1	0.1	10 μA to 0.18 mA
110 to 329.99999 kΩ	25	32	2	10	0.1	1 μA to 0.05 mA
330 kΩ to 1.099999 MΩ	25	32	2	10	1	1 μA to 0.018 mA
1.1 to 3.299999 MΩ	40	60	30	150	1	250 nA to 5 μA
3.3 to 10.99999 MΩ	110	130	50	250	10	250 nA to 1.8 μA
11 to 32.99999 MΩ	200	250	2500	2500	10	25 nA to 500 nA
33 to 109.9999 MΩ	400	500	3000	3000	100	25 nA to 180 nA
110 to 329.9999 MΩ	2500	3000	100000	100000	1000	2.5 nA to 50 nA
330 to 1100 MΩ	12000	15000	500000	500000	10000	1 nA to 13 nA

[1] Continuously variable from 0 Ω □ to 1.1 GΩ.  
[2] Applies for 4-WIRE compensation only. For 2-WIRE and 2-WIRE COMP, add an additional amount to the floor specification as calculated by: (5 μV divided by the stimulus current in amps). For example, in 2-WIRE mode, at 1 kΩ the floor specification within 12 hours of an ohms zero cal for a measurement current of 1 mA is: 0.002 Ω + (5 μV / 1 mA) = (0.002 + 0.005) Ω = 0.007 Ω.  
[3] For currents lower than shown, the floor adder increases by Floor(new) = Floor(old) x Imin/Iactual. For example, a 50 μA stimulus measuring 100 Ω has a floor specification of: 0.0014 Ω x 1 mA/50 μA = 0.028 Ω assuming an ohms zero calibration within 12 hours.

**AC Voltage (Sine Wave)**

Range	Frequency	Absolute Uncertainty, tcal ±5 °C ±(ppm of output + μV)		Resolution	Max Burden	Max Distortion and Noise 10 Hz to 5 MHz Bandwidth ±(% of output + floor)
		90 days	1 year			
Normal Output						
1.0 mV to 32.999 mV	10 Hz to 45 Hz	600 + 6	800 + 6	1 μV	65 Ω	0.15 + 90 μV
	45 Hz to 10 kHz	120 + 6	150 + 6			0.035 + 90 μV
	10 kHz to 20 kHz	160 + 6	200 + 6			0.06 + 90 μV
	20 kHz to 50 kHz	800 + 6	1000 + 6			0.15 + 90 μV
	50 kHz to 100 kHz	3000 + 12	3500 + 12			0.25 + 90 μV
	100 kHz to 500 kHz	6000 + 50	8000 + 50			0.3 + 90 μV <sup>[1]</sup>
33 mV to 329.999 mV	10 Hz to 45 Hz	250 + 8	300 + 8	1 μV	65 Ω	0.15 + 90 μV
	45 Hz to 10 kHz	140 + 8	145 + 8			0.035 + 90 μV
	10 kHz to 20 kHz	150 + 8	160 + 8			0.06 + 90 μV
	20 kHz to 50 kHz	300 + 8	350 + 8			0.15 + 90 μV
	50 kHz to 100 kHz	600 + 32	800 + 32			0.20 + 90 μV
	100 kHz to 500 kHz	1600 + 70	2000 + 70			0.20 + 90 μV <sup>[1]</sup>
0.33 V to 3.29999 V	10 Hz to 45 Hz	250 + 50	300 + 50	10 μV	10 mA	0.15 + 200 μV
	45 Hz to 10 kHz	140 + 60	150 + 60			0.035 + 200 μV
	10 kHz to 20 kHz	160 + 60	190 + 60			0.06 + 200 μV
	20 kHz to 50 kHz	250 + 50	300 + 50			0.15 + 200 μV
	50 kHz to 100 kHz	550 + 125	700 + 125			0.20 + 200 μV
	100 kHz to 500 kHz	2000 + 600	2400 + 600			0.20 + 200 μV <sup>[1]</sup>
3.3 V to 32.9999 V	10 Hz to 45 Hz	250 + 650	300 + 650	100 μV	10 mA	0.15 + 2 mV
	45 Hz to 10 kHz	125 + 600	150 + 600			0.035 + 2 mV
	10 kHz to 20 kHz	220 + 600	240 + 600			0.08 + 2 mV
	20 kHz to 50 kHz	300 + 600	350 + 600			0.2 + 2 mV
	50 kHz to 100 kHz	750 + 1600	900 + 1600			0.5 + 2 mV
33 V to 329.999 V	45 Hz to 1 kHz	150 + 2000	190 + 2000	1 mV	5 mA, except 20 mA for 45 Hz to 65 Hz	0.15 + 10 mV
	1 kHz to 10 kHz	160 + 6000	200 + 6000			0.05 + 10 mV
	10 kHz to 20 kHz	220 + 6000	250 + 6000			0.6 + 10 mV
	20 kHz to 50 kHz	240 + 6000	300 + 6000			0.8 + 10 mV
	50 kHz to 100 kHz	1600 + 50000	2000 + 50000			1.0 + 10 mV
330 V to 1020 V	45 Hz to 1 kHz	250 + 10000	300 + 10000	10 mV	2 mA, except 6 mA for 45 Hz to 65 Hz	0.15 + 30 mV
	1 kHz to 5 kHz	200 + 10000	250 + 10000			0.07 + 30 mV
	5 kHz to 10 kHz	250 + 10000	300 + 10000			0.07 + 30 mV

[1] Max Distortion for 100 kHz to 200 kHz. For 200 kHz to 500 kHz, the maximum distortion is 0.9 % of output + floor as shown.

Note  
Remote sensing is not provided. Output resistance is <5 mΩ for outputs ≥0.33 V. The AUX output resistance is <1 Ω. The maximum load capacitance is 500 pF, subject to the maximum burden current limits

**AC Voltage (Sine Wave) (cont.)**

Range	Frequency <sup>[1]</sup>	Absolute Uncertainty, tcal ±5 °C ±(% of output + μV)		Resolution	Max Burden	Max Distortion and Noise 10 Hz to 5 MHz Bandwidth ±(% of output + floor)
		90 days	1 year			
AUX Output						
10 mV to 329.999 mV	10 Hz to 20 Hz	0.15 + 370	0.2 + 370	1 μV	5 mA	0.2 + 200 μV
	20 Hz to 45 Hz	0.08 + 370	0.1 + 370			0.06 + 200 μV
	45 Hz to 1 kHz	0.08 + 370	0.1 + 370			0.08 + 200 μV
	1 kHz to 5 kHz	0.15 + 450	0.2 + 450			0.3 + 200 μV
	5 kHz to 10 kHz	0.3 + 450	0.4 + 450			0.6 + 200 μV
	10 kHz to 30 kHz	4.0 + 900	5.0 + 900			1 + 200 μV
0.33 V to 3.29999 V	10 Hz to 20 Hz	0.15 + 450	0.2 + 450	10 μV	5 mA	0.2 + 200 μV
	20 Hz to 45 Hz	0.08 + 450	0.1 + 450			0.06 + 200 μV
	45 Hz to 1 kHz	0.07 + 450	0.09 + 450			0.08 + 200 μV
	1 kHz to 5 kHz	0.15 + 1400	0.2 + 1400			0.3 + 200 μV
	5 kHz to 10 kHz	0.3 + 1400	0.4 + 1400			0.6 + 200 μV
	10 kHz to 30 kHz	4.0 + 2800	5.0 + 2800			1 + 200 μV
3.3 V to 5 V	10 Hz to 20 Hz	0.15 + 450	0.2 + 450	100 μV	5 mA	0.2 + 200 μV
	20 Hz to 45 Hz	0.08 + 450	0.1 + 450			0.06 + 200 μV
	45 Hz to 1 kHz	0.07 + 450	0.09 + 450			0.08 + 200 μV
	1 kHz to 5 kHz	0.15 + 1400	0.2 + 1400			0.3 + +200 μV
	5 kHz to 10 kHz	0.3 + 1400	0.4 + 1400			0.6 + 200 μV
<p>[1] There are two channels of voltage output. The maximum frequency of the dual output is 30 kHz.</p> <p>Note Remote sensing is not provided. Output resistance is &lt;5 mΩ for outputs ≥0.33 V. The AUX output resistance is &lt;1 Ω. The maximum load capacitance is 500 pF, subject to the maximum burden current limits</p>						

**AC Current (Sine Wave)**

Range	Frequency	Absolute Uncertainty, tcal ±5 °C ±(% of output + μA)		Compliance adder ±(μA/V)	Max Distortion & Noise 10 Hz to 100 kHz BW ±(% of output + floor)	Max Inductive Load μH
		90 days	1 year			
<b>LCOMP Off</b>						
29.00 to 329.99 μA	10 to 20 Hz	0.16 + 0.1	0.2 + 0.1	0.05	0.15 + 0.5 μA	200
	20 to 45 Hz	0.12 + 0.1	0.15 + 0.1	0.05	0.1 + 0.5 μA	
	45 Hz to 1 kHz	0.1 + 0.1	0.125 + 0.1	0.05	0.05 + 0.5 μA	
	1 to 5 kHz	0.25 + 0.15	0.3 + 0.15	1.5	0.5 + 0.5 μA	
	5 to 10 kHz	0.6 + 0.2	0.8 + 0.2	1.5	1.0 + 0.5 μA	
0.33 to 3.29999 mA	10 to 20 Hz	0.16 + 0.15	0.2 + 0.15	0.05	0.15 + 1.5 μA	200
	20 to 45 Hz	0.1 + 0.15	0.125 + 0.15	0.05	0.06 + 1.5 μA	
	45 Hz to 1 kHz	0.08 + 0.15	0.1 + 0.15	0.05	0.02 + 1.5 μA	
	1 to 5 kHz	0.16 + 0.2	0.2 + 0.2	1.5	0.5 + 1.5 μA	
	5 to 10 kHz	0.4 + 0.3	0.5 + 0.3	1.5	1.0 + 1.5 μA	
3.3 to 32.9999 mA	10 to 20 Hz	0.15 + 2	0.18 + 2	0.05	0.15 + 5 μA	50
	20 to 45 Hz	0.075 + 2	0.09 + 2	0.05	0.05 + 5 μA	
	45 Hz to 1 kHz	0.035 + 2	0.04 + 2	0.05	0.07 + 5 μA	
	1 to 5 kHz	0.065 + 2	0.08 + 2	1.5	0.3 + 5 μA	
	5 to 10 kHz	0.16 + 3	0.2 + 3	1.5	0.7 + 5 μA	
33 to 329.999 mA	10 to 20 Hz	0.15 + 20	0.18 + 20	0.05	0.15 + 50 μA	50
	20 to 45 Hz	0.075 + 20	0.09 + 20	0.05	0.05 + 50 μA	
	45 Hz to 1 kHz	0.035 + 20	0.04 + 20	0.05	0.02 + 50 μA	
	1 to 5 kHz	0.08 + 50	0.10 + 50	1.5	0.03 + 50 μA	
	5 to 10 kHz	0.16 + 100	0.2 + 100	1.5	0.1 + 50 μA	
0.33 to 1.09999 A	10 to 45 Hz	0.15 + 100	0.18 + 100		0.2 + 500 μA	2.5
	45 Hz to 1 kHz	0.036 + 100	0.05 + 100		0.07 + 500 μA	
	1 to 5 kHz	0.5 + 1000	0.6 + 1000	[2]	1 + 500 μA	
	5 to 10 kHz	2.0 + 5000	2.5 + 5000	[3]	2 + 500 μA	
1.1 to 2.99999 A	10 to 45 Hz	0.15 + 100	0.18 + 100		0.2 + 500 μA	2.5
	45 Hz to 1 kHz	0.05 + 100	0.06 + 100		0.07 + 500 μA	
	1 to 5 kHz	0.5 + 1000	0.6 + 1000	[2]	1 + 500 μA	
	5 to 10 kHz	2.0 + 5000	2.5 + 5000	[3]	2 + 500 μA	
3 to 10.9999 A	45 to 100 Hz	0.05 + 2000	0.06 + 2000		0.2 + 3 mA	1
	100 Hz to 1 kHz	0.08 + 2000	0.10 + 2000		0.1 + 3 mA	
	1 to 5 kHz	2.5 + 2000	3.0 + 2000		0.8 + 3 mA	
11 to 20.5 A [1]	45 to 100 Hz	0.1 + 5000	0.12 + 5000		0.2 + 3 mA	1
	100 Hz to 1 kHz	0.13 + 5000	0.15 + 5000		0.1 + 3 mA	
	1 to 5 kHz	2.5 + 5000	3.0 + 5000		0.8 + 3 mA	

[1] Duty Cycle: Currents <11 A may be provided continuously. For currents >11 A, see Figure 1. The current may be provided 60-T-I minutes any 60 minute period where T is the temperature in °C (room temperature is about 23 °C) and I is the output current in Amps. For example, 17 A, at 23 °C could be provided for 60-23-17 = 20 minutes each hour. When the 5522A is outputting currents between 5 and 11 amps for long periods, the internal self-heating reduces the duty cycle. Under those conditions, the allowable "on" time indicated by the formula and Figure 1 is achieved only after the 5522A is outputting currents <5 A for the "off" period first.

[2] For compliance voltages greater than 1 V, add 1 mA/V to the floor specification from 1 to 5 kHz.

[3] For compliance voltages greater than 1 V, add 5 mA/V to the floor specification from 5 to 10 kHz.

**AC Current (Sine Wave) (cont.)**

Range	Frequency	Absolute Uncertainty, tcal ±5 °C ±(% of output + μA)		Max Distortion & Noise 10 Hz to 100 kHz BW ±(% of output + floor)	Max Inductive Load μH
		90 days	1 year		
<b>LCOMP On</b>					
29.00 to 329.99 μA	10 to 100 Hz	0.2 + 0.2	0.25 + 0.2	0.1 + 1.0 μA	400
	100 Hz to 1 kHz	0.5 + 0.5	0.6 + 0.5	0.05 + 1.0 μA	
0.33 to 3.29999 mA	10 to 100 Hz	0.2 + 0.3	0.25 + 0.3	0.15 + 1.5 μA	
	100 Hz to 1 kHz	0.5 + 0.8	0.6 + 0.8	0.06 + 1.5 μA	
3.3 to 32.9999 mA	10 to 100 Hz	0.07 + 4	0.08 + 4	0.15 + 5 μA	
	100 Hz to 1 kHz	0.18 + 10	0.2 + 10	0.05 + 5 μA	
33 to 329.999 mA	10 to 100 Hz	0.07 + 40	0.08 + 40	0.15 + 50 μA	
	100 Hz to 1 kHz	0.18 + 100	0.2 + 100	0.05 + 50 μA	
0.33 to 2.99999 A	10 to 100 Hz	0.1 + 200	0.12 + 200	0.2 + 500 μA	
	100 to 440 Hz	0.25 + 1000	0.3 + 1000	0.25 + 500 μA	
3 to 20.5 A <sup>[1]</sup>	45 to 100 Hz	0.1 + 2000 <sup>[2]</sup>	0.12 + 2000 <sup>[2]</sup>	0.1 + 0 μA	400 <sup>[4]</sup>
	100 to 440 Hz	0.8 + 5000 <sup>[3]</sup>	1.0 + 5000 <sup>[3]</sup>	0.5 + 0 μA	
<p>[1] Duty Cycle: Currents &lt;11 A may be provided continuously. For currents &gt;11 A, see Figure 1. The current may be provided Formula 60-T-I minutes any 60 minute period where T is the temperature in °C (room temperature is about 23 °C) and I is the output current in Amps. For example, 17 A, at 23 °C could be provided for 60-23-17 = 20 minutes each hour. When the 5522A is outputting currents between 5 and 11 amps for long periods, the internal self-heating reduces the duty cycle. Under those conditions, the allowable "on" time indicated by the formula and Figure 1 is achieved only after the 5522A is outputting currents &lt;5 A for the "off" period first.</p> <p>[2] For currents &gt;11 A, Floor specification is 4000 μA within 30 seconds of selecting operate. For operating times &gt;30 seconds, the floor specification is 2000 μA.</p> <p>[3] For currents &gt;11 A, Floor specification is 10000 μA within 30 seconds of selecting operate. For operating times &gt;30 seconds, the floor specification is 5000 μA.</p> <p>[4] Subject to compliance voltages limits.</p>					

Range	Resolution μA	Max Compliance Voltage V rms <sup>[1]</sup>
0.029 to 0.32999 mA	0.01	7
0.33 to 3.29999 mA	0.01	7
3.3 to 32.9999 mA	0.1	5
33 to 329.999 mA	1	5
0.33 to 2.99999 A	10	4
3 to 20.5 A	100	3
[1] Subject to specification adder for compliance voltages greater than 1 V rms.		

## Capacitance

Range	Absolute Uncertainty, tcal ±5 °C ±(% of output + floor) <sup>[1] [2] [3]</sup>		Resolution	Allowed Frequency or Charge-Discharge Rate		
	90 days	1 year		Min and Max to Meet Specification	Typical Max for <0.5 % Error	Typical Max for <1 % Error
220.0 to 399.9 pF	0.38 + 10 pF	0.5 + 10 pF	0.1 pF	10 Hz to 10 kHz	20 kHz	40 kHz
0.4 to 1.0999 nF	0.38 + 0.01 nF	0.5 + 0.01 nF	0.1 pF	10 Hz to 10 kHz	30 kHz	50 kHz
1.1 to 3.2999 nF	0.38 + 0.01 nF	0.5 + 0.01 nF	0.1 pF	10 Hz to 3 kHz	30 kHz	50 kHz
3.3 to 10.9999 nF	0.19 + 0.01 nF	0.25 + 0.01 nF	0.1 pF	10 Hz to 1 kHz	20 kHz	25 kHz
11 to 32.9999 nF	0.19 + 0.1 nF	0.25 + 0.1 nF	0.1 pF	10 Hz to 1 kHz	8 kHz	10 kHz
33 to 109.999 nF	0.19 + 0.1 nF	0.25 + 0.1 nF	1 pF	10 Hz to 1 kHz	4 kHz	6 kHz
110 to 329.999 nF	0.19 + 0.3 nF	0.25 + 0.3 nF	1 pF	10 Hz to 1 kHz	2.5 kHz	3.5 kHz
0.33 to 1.09999 μF	0.19 + 1 nF	0.25 + 1 nF	10 pF	10 to 600 Hz	1.5 kHz	2 kHz
1.1 to 3.29999 μF	0.19 + 3 nF	0.25 + 3 nF	10 pF	10 to 300 Hz	800 Hz	1 kHz
3.3 to 10.9999 μF	0.19 + 10 nF	0.25 + 10 nF	100 pF	10 to 150 Hz	450 Hz	650 Hz
11 to 32.9999 μF	0.30 + 30 nF	0.40 + 30 nF	100 pF	10 to 120 Hz	250 Hz	350 Hz
33 to 109.999 μF	0.34 + 100 nF	0.45 + 100 nF	1 nF	10 to 80 Hz	150 Hz	200 Hz
110 to 329.999 μF	0.34 + 300 nF	0.45 + 300 nF	1 nF	0 to 50 Hz	80 Hz	120 Hz
0.33 to 1.09999 mF	0.34 + 1 μF	0.45 + 1 μF	10 nF	0 to 20 Hz	45 Hz	65 Hz
1.1 to 3.29999 mF	0.34 + 3 μF	0.45 + 3 μF	10 nF	0 to 6 Hz	30 Hz	40 Hz
3.3 to 10.9999 mF	0.34 + 10 μF	0.45 + 10 μF	100 nF	0 to 2 Hz	15 Hz	20 Hz
11 to 32.9999 mF	0.7 + 30 μF	0.75 + 30 μF	100 nF	0 to 0.6 Hz	7.5 Hz	10 Hz
33 to 110 mF	1.0 + 100 μF	1.1 + 100 μF	10 μF	0 to 0.2 Hz	3 Hz	5 Hz

[1] The output is continuously variable from 220 pF to 110 mF.  
 [2] Specifications apply to both dc charge/discharge capacitance meters and ac RCL meters. The maximum allowable peak voltage is 3 V. The maximum allowable peak current is 150 mA, with an rms limitation of 30 mA below 1.1 μF and 100 mA for 1.1 μF and above.  
 [3] The maximum lead resistance for no additional error in 2-wire COMP mode is 10 Ω.

**Temperature Calibration (Thermocouple)**

TC Type <sup>[1]</sup>	Range °C <sup>[2]</sup>	Absolute Uncertainty Source/Measure tcal ±5 °C ± °C <sup>[3]</sup>		TC Type <sup>[1]</sup>	Range °C <sup>[2]</sup>	Absolute Uncertainty Source/Measure tcal ±5 °C ± °C <sup>[3]</sup>	
		90 days	1 year			90 days	1 year
B	600 to 800	0.42	0.44	L	-200 to -100	0.37	0.37
	800 to 1000	0.34	0.34		-100 to 800	0.26	0.26
	1000 to 1550	0.30	0.30		800 to 900	0.17	0.17
	1550 to 1820	0.26	0.33	N	-200 to -100	0.30	0.40
C	0 to 150	0.23	0.30		-100 to -25	0.17	0.22
	150 to 650	0.19	0.26		-25 to 120	0.15	0.19
	650 to 1000	0.23	0.31		120 to 410	0.14	0.18
	1000 to 1800	0.38	0.50		410 to 1300	0.21	0.27
	1800 to 2316	0.63	0.84	R	0 to 250	0.48	0.57
E	-250 to -100	0.38	0.50		250 to 400	0.28	0.35
	-100 to -25	0.12	0.16		400 to 1000	0.26	0.33
	-25 to 350	0.10	0.14		1000 to 1767	0.30	0.40
	350 to 650	0.12	0.16	S	0 to 250	0.47	0.47
	650 to 1000	0.16	0.21		250 to 1000	0.30	0.36
J	-210 to -100	0.20	0.27		1000 to 1400	0.28	0.37
	-100 to -30	0.12	0.16	1400 to 1767	0.34	0.46	
	-30 to 150	0.10	0.14	T	-250 to -150	0.48	0.63
	150 to 760	0.13	0.17		-150 to 0	0.18	0.24
	760 to 1200	0.18	0.23		0 to 120	0.12	0.16
K	-200 to -100	0.25	0.33		120 to 400	0.10	0.14
	-100 to -25	0.14	0.18	U	-200 to 0	0.56	0.56
	-25 to 120	0.12	0.16		0 to 600	0.27	0.27
	120 to 1000	0.19	0.26				
	1000 to 1372	0.30	0.40				

[1] Temperature standard ITS-90 or IPTS-68 is selectable.  
TC simulating and measuring are not specified for operation in electromagnetic fields above 0.4 V/m.

[2] Resolution is 0.01 °C

[3] Does not include thermocouple error

**Temperature Calibration (RTD)**

RTD Type	Range °C <sup>[1]</sup>	Absolute Uncertainty tcal ±5 °C ± °C <sup>[2]</sup>		RTD Type	Range °C <sup>[1]</sup>	Absolute Uncertainty tcal ±5 °C ± °C <sup>[2]</sup>	
		90 days	1 year			90 days	1 year
Pt 385, 100 Ω	-200 to -80	0.04	0.05	Pt 385, 500 Ω	-200 to -80	0.03	0.04
	-80 to 0	0.05	0.05		-80 to 0	0.04	0.05
	0 to 100	0.07	0.07		0 to 100	0.05	0.05
	100 to 300	0.08	0.09		100 to 260	0.06	0.06
	300 to 400	0.09	0.10		260 to 300	0.07	0.08
	400 to 630	0.10	0.12		300 to 400	0.07	0.08
	630 to 800	0.21	0.23		400 to 600	0.08	0.09
Pt 3926, 100 Ω	-200 to -80	0.04	0.05		Pt 385, 1000 Ω	600 to 630	0.09
	-80 to 0	0.05	0.05	-200 to -80		0.03	0.03
	0 to 100	0.07	0.07	-80 to 0		0.03	0.03
	100 to 300	0.08	0.09	0 to 100		0.03	0.04
	300 to 400	0.09	0.10	100 to 260		0.04	0.05
400 to 630	0.10	0.12	260 to 300	0.05		0.06	
Pt 3916, 100 Ω	-200 to -190	0.25	0.25	300 to 400		0.05	0.07
	-190 to -80	0.04	0.04	400 to 600		0.06	0.07
	-80 to 0	0.05	0.05	600 to 630	0.22	0.23	
	0 to 100	0.06	0.06	PtNi 385, 120 Ω (Ni120)	-80 to 0	0.06	0.08
	100 to 260	0.06	0.07		0 to 100	0.07	0.08
	260 to 300	0.07	0.08		100 to 260	0.13	0.14
	300 to 400	0.08	0.09	Cu 427 10 Ω <sup>[3]</sup>	-100 to 260	0.3	0.3
	400 to 600	0.08	0.10				
600 to 630	0.21	0.23					
Pt 385, 200 Ω	-200 to -80	0.03	0.04				
	-80 to 0	0.03	0.04				
	0 to 100	0.04	0.04				
	100 to 260	0.04	0.05				
	260 to 300	0.11	0.12				
	300 to 400	0.12	0.13				
	400 to 600	0.12	0.14				
	600 to 630	0.14	0.16				

[1] Resolution is 0.003 °C  
 [2] Applies for COMP OFF (to the 5522A Calibrator front panel NORMAL terminals) and 2-wire and 4-wire compensation.  
 [3] Based on MINCO Application Aid No. 18

### DC Power Specification Summary

	Voltage Range	Current Range		
		0.33 to 329.99 mA	0.33 to 2.9999 A	3 to 20.5 A
		Absolute Uncertainty, tcal $\pm 5$ °C, $\pm$ (% of watts output) <sup>[1]</sup>		
90 days	33 mV to 1020 V	0.021	0.019 <sup>[2]</sup>	0.06 <sup>[2]</sup>
1 year	33 mV to 1020 V	0.023	0.022 <sup>[2]</sup>	0.07 <sup>[2]</sup>

[1] To determine dc power uncertainty with more precision, see the individual "DC Voltage Specifications," "DC Current Specifications," and "Calculating Power Uncertainty."  
[2] Add 0.02 % unless a settling time of 30 seconds is allowed for output currents >10 A or for currents on the highest two current ranges within 30 seconds of an output current >10 A.

### AC Power (45 Hz to 65 Hz) Specification Summary, PF=1

	Voltage Range	Current Range			
		3.3 to 8.999 mA	9 to 32.999 mA	33 to 89.99 mA	90 to 329.99 mA
		Absolute Uncertainty, tcal $\pm 5$ °C, $\pm$ (% of watts output) <sup>[1]</sup>			
90 days	33 to 329.999 mV	0.13	0.09	0.13	0.09
	330 mV to 1020 V	0.11	0.07	0.11	0.07
1 year	33 to 329.999 mV	0.14	0.10	0.14	0.10
	330 mV to 1020 V	0.12	0.08	0.12	0.08

	Voltage Range	Current Range <sup>[2]</sup>			
		0.33 to 0.8999 A	0.9 to 2.1999 A	2.2 to 4.4999 A	4.5 to 20.5 A
		Absolute Uncertainty, tcal $\pm 5$ °C, $\pm$ (% of watts output) <sup>[1]</sup>			
90 days	33 to 329.999 mV	0.12	0.10	0.12	0.10
	330 mV to 1020 V	0.10	0.08	0.11	0.09
1 year	33 to 329.999 mV	0.13	0.11	0.13	0.11
	330 mV to 1020 V	0.11	0.09	0.12	0.10

[1] To determine ac power uncertainty with more precision, see the individual "AC Voltage Specifications" and "AC Current Specifications" and "Calculating Power Uncertainty."  
[2] Add 0.02 % unless a settling time of 30 seconds is allowed for output currents >10 A or for currents on the highest two current ranges within 30 seconds of an output current >10 A.

### Power and Dual Output Limit Specifications

Frequency	Voltages (NORMAL)	Currents	Voltages (AUX)	Power Factor (PF)
dc	0 to $\pm 1020$ V	0 to $\pm 20.5$ A	0 to $\pm 7$ V	—
10 to 45 Hz	33 mV to 32.9999 V	3.3 mA to 2.99999 A	10 mV to 5 V	0 to 1
45 to 65 Hz	33 mV to 1020 V	3.3 mA to 20.5 A	10 mV to 5 V	0 to 1
65 to 500 Hz	330 mV to 1020 V	33 mA to 2.99999 A	100 mV to 5 V	0 to 1
65 to 500 Hz	3.3 to 1020 V	33 mA to 20.5 A	100 mV to 5 V	0 to 1
500 Hz to 1 kHz	330 mV to 1020 V	33 mA to 20.5 A	100 mV to 5 V	0 to 1
1 to 5 kHz	3.3 to 500 V	33 mA to 2.99999 A	100 mV to 5 V	0 to 1
5 to 10 kHz	3.3 to 250 V	33 to 329.99 mA	1 to 5 V	0 to 1
10 to 30 kHz	3.3 V to 250 V	33 mA to 329.99 mA	1 V to 3.29999 V	0 to 1

Notes  
The range of voltages and currents shown in "DC Voltage Specifications," "DC Current Specifications," "AC Voltage (Sine Wave) Specifications," and "AC Current (Sine Wave) Specifications" are available in the power and dual output modes (except minimum current for ac power is 0.33 mA). However, only those limits shown in this table are specified. See "Calculating Power Uncertainty" to determine the uncertainty at these points.  
The phase adjustment range for dual ac outputs is 0 ° to  $\pm 179.99$  °. The phase resolution for dual ac outputs is 0.01 degree.

**Phase**

1-Year Absolute Uncertainty, tc al ±5 °C, (Δ Φ °)					
10 to 65 Hz	65 to 500 Hz	500 Hz to 1 kHz	1 to 5 kHz	5 to 10 kHz	10 to 30 kHz
0.10 °	0.25 °	0.5 °	2.5 °	5 °	10 °
Note See Power and Dual Output Limit Specifications for applicable outputs.					

Phase (Φ) Watts	Phase (Φ) VARs	PF	Power Uncertainty Adder due to Phase Error					
			10 to 65 Hz	65 to 500 Hz	500 Hz to 1 kHz	1 to 5 kHz	5 to 10 kHz	10 to 30 kHz
0 °	90 °	1.000	0.00 %	0.00 %	0.00 %	0.10 %	0.38 %	1.52 %
10 °	80 °	0.985	0.03 %	0.08 %	0.16 %	0.86 %	1.92 %	4.58 %
20 °	70 °	0.940	0.06 %	0.16 %	0.32 %	1.68 %	3.55 %	7.84 %
30 °	60 °	0.866	0.10 %	0.25 %	0.51 %	2.61 %	5.41 %	11.54 %
40 °	50 °	0.766	0.15 %	0.37 %	0.74 %	3.76 %	7.69 %	16.09 %
50 °	40 °	0.643	0.21 %	0.52 %	1.04 %	5.29 %	10.77 %	22.21 %
60 °	30 °	0.500	0.30 %	0.76 %	1.52 %	7.65 %	15.48 %	31.60 %
70 °	20 °	0.342	0.48 %	1.20 %	2.40 %	12.08 %	24.33 %	49.23 %
80 °	10 °	0.174	0.99 %	2.48 %	4.95 %	24.83 %	49.81 %	100.00 %
90 °	0 °	0.000	—	—	—	—	—	—

To calculate exact ac Watts power adders due to phase uncertainty for values not shown, use the following formula:

$$Adder(\%) = 100 \left( 1 - \frac{\cos(\Phi + \Delta\Phi)}{\cos(\Phi)} \right)$$

For example: At 60 Hz, for a PF of .9205 (Φ = 23) and a phase uncertainty of ΔΦ = 0.10, the ac Watts power adder is:

$$Adder(\%) = 100 \left( 1 - \frac{\cos(23 + .10)}{\cos(23)} \right) = 0.074\%$$

**Calculating Power Uncertainty**

Overall uncertainty for power output in Watts (or VARs) is based on the root sum square (rss) of the individual uncertainties in percent for the selected voltage, current, and power factor parameters:

Watts uncertainty  $U_{power} = \sqrt{U_{voltage}^2 + U_{current}^2 + U_{PFadder}^2}$

VARs uncertainty  $U_{VARs} = \sqrt{U_{voltage}^2 + U_{current}^2 + U_{VARsadder}^2}$

Because there are an infinite number of combinations, you should calculate the actual ac power uncertainty for your selected parameters. The method of calculation is best shown in the following examples (using 1 year specifications):

**Example 1** Output: 100 V, 1 A, 60 Hz, Power Factor = 1.0 (Φ=0).

**Voltage Uncertainty** Uncertainty for 100 V at 60 Hz is 190 ppm + 2 mV, totaling:  
 100 V x 190 x 10<sup>-6</sup> = 19 mV added to 2 mV = 21 mV. Expressed in percent:  
 21 mV/100 V x 100 = 0.021 % (see "AC Voltage (Sine Wave) Specifications").

**Current Uncertainty** Uncertainty for 1 A is 0.05 % □ 100 μA, totaling:  
 1 A x 0.0005 = 500 μA added to 100 μA = 0.6 mA. Expressed in percent:  
 0.6 mA/1 A x 100 = 0.06 % (see "AC Current (Sine Waves) Specifications").

**PF Adder** Watts Adder for PF = 1 (Φ=0) at 60 Hz is 0 % (see "Phase Specifications").

Total Watts Output Uncertainty =  $U_{power} = \sqrt{0.021^2 + 0.06^2 + 0^2} = 0.064\%$

**Example 2** Output: 100 V, 1 A, 400 Hz, Power Factor = 0.5 (Φ=60)

**Voltage Uncertainty** Uncertainty for 100 V at 400 Hz is, 190 ppm + 2 mV, totaling:  
 100 V x 190 x 10<sup>-6</sup> = 19 mV added to 2 mV = 21 mV. Expressed in percent:  
 21 mV/100 V x 100 = 0.021 % (see "AC Voltage (Sine Wave) Specifications").

**Current Uncertainty** Uncertainty for 1 A is 0.05 % □ 100 μA, totaling:  
 1 A x 0.0005 = 500 μA added to 100 μA = 0.6 mA. Expressed in percent:  
 0.6 mA/1 A x 100 = 0.06 % (see "AC Current (Sine Waves) Specifications").

**PF Adder** Watts Adder for PF = 0.5 (Φ=60) at 400 Hz is 0.76 % (see "Phase Specifications").

$$\text{Total Watts Output Uncertainty} = U_{\text{power}} = \sqrt{0.021^2 + 0.06^2 + 0.76^2} = 0.76\%$$

**VARs** When the Power Factor approaches 0.0, the Watts output uncertainty becomes unrealistic because the dominant characteristic is the VARs (volts-amps-reactive) output. In these cases, calculate the Total VARs Output Uncertainty, as shown in example 3:

**Example 3** Output: 100 V, 1 A, 60 Hz, Power Factor = 0.174 ( $\Phi=80$ )

**Voltage Uncertainty** Uncertainty for 100 V at 60 Hz is, 190 ppm + 2 mV, totaling:  
 $100 \text{ V} \times 190 \times 10^{-6} = 19 \text{ mV}$  added to 2 mV = 21 mV. Expressed in percent:  
 $21 \text{ mV}/100 \text{ V} \times 100 = 0.021\%$  (see "AC Voltage (Sine Wave) Specifications").

**Current Uncertainty** Uncertainty for 1 A is 0.05 %  $\square$  100  $\mu\text{A}$ , totaling:  
 $1 \text{ A} \times 0.0005 = 500 \mu\text{A}$  added to 100  $\mu\text{A} = 0.6 \text{ mA}$ . Expressed in percent:  
 $0.6 \text{ mA}/1 \text{ A} \times 100 = 0.06\%$  (see "AC Current (Sine Waves) Specifications").

**VARs Adder** VARs Adder for  $\Phi=80$  at 60 Hz is 0.03 % (see "Phase Specifications").

$$\text{Total VARs Output Uncertainty} = U_{\text{VARs}} = \sqrt{0.021^2 + 0.06^2 + 0.03^2} = 0.070\%$$

## Additional Specifications

The following paragraphs provide additional specifications for the 5522A Calibrator ac voltage and ac current functions. These specifications are valid after allowing a warm-up period of 30 minutes, or twice the time the 5522A has been turned off. All extended range specifications are based on performing the internal zero-cal function at weekly intervals, or when the ambient temperature changes by more than 5 °C.

### Frequency

Frequency Range	Resolution	1-Year Absolute Uncertainty, tcal $\pm 5$ °C	Jitter
0.01 to 119.99 Hz	0.01 Hz	2.5 ppm +5 $\mu\text{Hz}$ <sup>[1]</sup>	100 ns
120.0 to 1199.9 Hz	0.1 Hz		
1.200 to 11.999 kHz	1.0 Hz		
12.00 to 119.99 kHz	10 Hz		
120.0 to 1199.9 kHz	100 Hz		
1.200 to 2.000 MHz	1 kHz		

[1] With REF CLK set to ext, the frequency uncertainty of the 5522A is the uncertainty of the external 10 MHz clock  $\pm 5$   $\mu\text{Hz}$ . The amplitude of the 10 MHz external reference clock signal should be between 1 V and 5 V p-p.

### Harmonics (2<sup>nd</sup> to 50<sup>th</sup>)

Fundamental Frequency <sup>[1]</sup>	Voltages NORMAL Terminals	Currents	Voltages AUX Terminals	Amplitude Uncertainty
10 to 45 Hz	33 mV to 32.9999 V	3.3 mA to 2.99999 A	10 mV to 5 V	Same % of output as the equivalent single output, but twice the floor adder.
45 to 65 Hz	33 mV to 1020 V	3.3 mA to 20.5 A	10 mV to 5 V	
65 to 500 Hz	33 mV to 1020 V	33 mA to 20.5 A	100 mV to 5 V	
500 Hz to 5 kHz	330 mV to 1020 V	33 mA to 20.5 A	100 mV to 5 V	
5 to 10 kHz	3.3 to 1020 V	33 to 329.9999 mA	100 mV to 5 V	
10 to 30 kHz	3.3 to 1020 V	33 to 329.9999 mA	100 mV to 3.29999 V	

[1] The maximum frequency of the harmonic output is 30 kHz (10 kHz for 3.3 to 5 V on the Aux terminals). For example, if the fundamental output is 5 kHz, the maximum selection is the 6th harmonic (30 kHz). All harmonic frequencies (2nd to 50th) are available for fundamental outputs between 10 Hz and 600 Hz (200 Hz for 3.3 to 5 V on the Aux terminals).

**Phase Uncertainty**..... Phase uncertainty for harmonic outputs is 1 degree or the phase uncertainty shown in "Phase Specifications" for the particular output, whichever is greater. For example, the phase uncertainty of a 400 Hz fundamental output and 10 kHz harmonic output is 5 ° (from "Phase Specifications"). Another example, the phase uncertainty of a 50 Hz fundamental output and a 400 Hz harmonic output is 1 degree.

**Example of determining Amplitude Uncertainty in a Dual Output Harmonic Mode**

**What are the amplitude uncertainties for the following dual outputs?**

NORMAL (Fundamental) Output:

100 V, 100 Hz ..... From “AC Voltage (Sine Wave) 90 Day Specifications” the single output specification for 100 V, 100 Hz, is 0.015 % + 2 mV. For the dual output in this example, the specification is 0.015 % +4 mV as the 0.015 % is the same, and the floor is twice the value (2 x 2 mV).

AUX (50th Harmonic) Output:

100 mV, 5 kHz ..... From “AC Voltage (Sine Wave) 90 Day Specifications” the auxiliary output specification for 100 mV, 5 kHz, is 0.15 % + 450 mV. For the dual output in this example, the specification is 0.15 % 900 mV as the 0.15 % is the same, and the floor is twice the value (2 x 450 mV).

**AC Voltage (Sine Wave) Extended Bandwidth**

Range	Frequency	1-Year Absolute Uncertainty tcal ±5 °C	Max Voltage Resolution
<b>Normal Channel (Single Output Mode)</b>			
1.0 to 33 mV	0.01 to 9.99 Hz	±(5.0 % of output +0.5 % of range)	Two digits, e.g., 25 mV
34 to 330 mV			Three digits
0.4 to 33 V			Two digits
0.3 to 3.3 V	500.1 kHz to 1 MHz	-10 dB at 1 MHz, typical	Two digits
	1.001 to 2 MHz	-31 dB at 2 MHz, typical	
<b>Auxiliary Output (Dual Output Mode)</b>			
10 to 330 mV	0.01 to 9.99 Hz	±(5.0 % of output +0.5 % of range)	Three digits
0.4 to 5 V			Two digits

### AC Voltage (Non-Sine Wave)

Triangle Wave & Truncated Sine Range, p-p <sup>[1]</sup>	Frequency	1-Year Absolute Uncertainty, tcal ±5 °C, ±(% of output + % of range) <sup>[2]</sup>	Max Voltage Resolution
<b>Normal Channel (Single Output Mode)</b>			
2.9 to 92.999 mV	0.01 to 10 Hz	5.0 + 0.5	Two digits on each range
	10 to 45 Hz	0.25 + 0.5	Six digits on each range
	45 Hz to 1 kHz	0.25 + 0.25	
	1 to 20 kHz	0.5 + 0.25	
	20 to 100 kHz <sup>[3]</sup>	5.0 + 0.5	
93 to 929.999 mV	0.01 to 10 Hz	5.0 + 0.5	Two digits on each range
	10 to 45 Hz	0.25 + 0.5	Six digits on each range
	45 Hz to 1 kHz	0.25 + 0.25	
	1 to 20 kHz	0.5 + 0.25	
	20 to 100 kHz <sup>[3]</sup>	5.0 + 0.5	
0.93 to 9.29999 V	0.01 to 10 Hz	5.0 + 0.5	Two digits on each range
	10 to 45 Hz	0.25 + 0.5	Six digits on each range
	45 Hz to 1 kHz	0.25 + 0.25	
	1 to 20 kHz	0.5 + 0.25	
	20 to 100 kHz <sup>[3]</sup>	5.0 + 0.5	
9.3 to 93 V	0.01 to 10 Hz	5.0 + 0.5	Two digits on each range
	10 to 45 Hz	0.25 + 0.5	Six digits on each range
	45 Hz to 1 kHz	0.25 + 0.25	
	1 to 20 kHz	0.5 + 0.25	
	20 to 100 kHz <sup>[3]</sup>	5.0 + 0.5	
<b>Auxiliary Output (Dual Output Mode)</b>			
29 to 929.999 mV	0.01 to 10 Hz	5.0 + 0.5	Two digits on each range
	10 to 45 Hz	0.25 + 0.5	Six digits on each range
	45 Hz to 1 kHz	0.25 + 0.25	
	1 to 10 kHz	5.0 + 0.5	
0.93 to 9.29999 V	0.01 to 10 Hz	5.0 + 0.5	Two digits on each range
	10 to 45 Hz	0.25 + 0.5	Six digits on each range
	45 Hz to 1 kHz	0.25 + 0.25	
	1 to 10 kHz	5.0 + 0.5	
9.3 to 14.0000 V	0.01 to 10 Hz	5.0 + 0.5	Two digits on each range
	10 to 45 Hz	0.25 + 0.5	Six digits on each range
	45 Hz to 1 kHz	0.25 + 0.25	
	1 to 10 kHz	5.0 + 0.5	
<p>[1] To convert p-p to rms for triangle wave, multiply the p-p value by 0.2886751. To convert p-p to rms for truncated sine wave, multiply the p-p value by 0.2165063.</p> <p>[2] Uncertainty is stated in p-p. Amplitude is verified using an rms-responding DMM.</p> <p>[3] Uncertainty for Truncated Sine outputs is typical over this frequency band.</p>			

**AC Voltage (Non-Sine Wave) (cont.)**

Square Wave Range (p-p) <sup>[1]</sup>	Frequency	1-Year Absolute Uncertainty, tcal ±5 °C, ±(% of output + % of range) <sup>[2]</sup>	Max Voltage Resolution
<b>Normal Channel (Single Output Mode)</b>			
2.9 to 65.999 mV	0.01 to 10 Hz	5.0 + 0.5	Two digits on each range
	10 to 45 Hz	0.25 + 0.5	Six digits on each range
	45 Hz to 1 kHz	0.25 + 0.25	
	1 to 20 kHz	0.5 + 0.25	
	20 to 100 kHz	5.0 + 0.5	
66 to 659.999 mV	0.01 to 10 Hz	5.0 + 0.5	Two digits on each range
	10 to 45 Hz	0.25 + 0.5	Six digits on each range
	45 Hz to 1 kHz	0.25 + 0.25	
	1 to 20 kHz	0.5 + 0.25	
	20 to 100 kHz	5.0 + 0.5	
0.66 to 6.59999 V	0.01 to 10 Hz	5.0 + 0.5	Two digits on each range
	10 to 45 Hz	0.25 + 0.5	Six digits on each range
	45 Hz to 1 kHz	0.25 + 0.25	
	1 to 20 kHz	0.5 + 0.25	
	20 to 100 kHz	5.0 + 0.5	
6.6 to 66.0000 V	0.01 to 10 Hz	5.0 + 0.5	Two digits on each range
	10 to 45 Hz	0.25 + 0.5	Six digits on each range
	45 Hz to 1 kHz	0.25 + 0.25	
	1 to 20 kHz	0.5 + 0.25	
	20 to 100 kHz	5.0 + 0.5	
<b>Auxiliary Output (Dual Output Mode)</b>			
29 to 659.999 mV	0.01 to 10 Hz	5.0 + 0.5	Two digits on each range
	10 to 45 Hz	0.25 + 0.5	Six digits on each range
	45 Hz to 1 kHz	0.25 + 0.25	
	1 to 10 kHz <sup>[3]</sup>	5.0 + 0.5	
0.66 to 6.59999 V	0.01 to 10 Hz	5.0 + 0.5	Two digits on each range
	10 to 45 Hz	0.25 + 0.5	Six digits on each range
	45 Hz to 1 kHz	0.25 + 0.25	
	1 to 10 kHz <sup>[3]</sup>	5.0 + 0.5	
6.6 to 14.0000 V	0.01 to 10 Hz	5.0 + 0.5	Two digits on each range
	10 to 45 Hz	0.25 + 0.5	Six digits on each range
	45 Hz to 1 kHz	0.25 + 0.25	
	1 to 10 kHz <sup>[3]</sup>	5.0 + 0.5	
<p>[1] To convert p-p to rms for square wave, multiply the p-p value by 0.5.</p> <p>[2] Uncertainty is stated in p-p. Amplitude is verified using an rms-responding DMM.</p> <p>[3] Limited to 1 kHz for Auxiliary outputs ≥6.6 V p-p.</p>			

### AC Voltage, DC Offset

Range <sup>[1]</sup> (Normal Channel)	Offset Range <sup>[2]</sup>	Max Peak Signal	1-Year Absolute Uncertainty, tcal ±5 °C <sup>[3]</sup> ±(% of dc output + floor)
<b>Sine Waves (rms)</b>			
3.3 to 32.999 mV	0 to 50 mV	80 mV	0.1 + 33 μV
33 to 329.999 mV	0 to 500 mV	800 mV	0.1 + 330 μV
0.33 to 3.29999 V	0 to 5 V	8 V	0.1 + 3300 μV
3.3 to 32.9999 V	0 to 50 V	55 V	0.1 + 33 mV
<b>Triangle Waves and Truncated Sine Waves (p-p)</b>			
9.3 to 92.999 mV	0 to 50 mV	80 mV	0.1 + 93 μV
93 to 929.999 mV	0 to 500 mV	800 mV	0.1 + 930 μV
0.93 to 9.29999 V	0 to 5 V	8 V	0.1 + 9300 μV
9.3 to 93.0000 V	0 to 50 V	55 V	0.1 + 93 mV
<b>Square Waves (p-p)</b>			
6.6 to 65.999 mV	0 to 50 mV	80 mV	0.1 + 66 μV
66 to 659.999 mV	0 to 500 mV	800 mV	0.1 + 660 μV
0.66 to 6.59999 V	0 to 5 V	8 V	0.1 + 6600 μV
6.6 to 66.0000 V	0 to 50 V	55 V	0.1 + 66 mV
<p>[1] Offsets are not allowed on ranges above the highest range shown above.</p> <p>[2] The maximum offset value is determined by the difference between the peak value of the selected voltage output and the allowable maximum peak signal. For example, a 10 V p-p square wave output has a peak value of 5 V, allowing a maximum offset up to ± 50 V to not exceed the 55 V maximum peak signal. The maximum offset values shown above are for the minimum outputs in each range.</p> <p>[3] For frequencies 0.01 to 10 Hz, and 500 kHz to 2 MHz, the offset uncertainty is 5 % of output, ±1 % of the offset range.</p>			

### AC Voltage, Square Wave Characteristics

Risetime @ 1 kHz Typical	Settling Time @ 1 kHz Typical	Overshoot @ 1 kHz Typical	Duty Cycle Range	Duty Cycle Uncertainty
<1 μs	<10 μs to 1 % of final value	<2 %	1 % to 99 % <3.3 V p-p. 0.01 Hz to 100 kHz	±(0.02 % of period + 100 ns), 50 % duty cycle ±(0.05 % of period + 100 ns), other duty cycles from 10 % to 90 %

### AC Voltage, Triangle Wave Characteristics (typical)

Linearity to 1 kHz	Aberrations
0.3 % of p-p value, from 10 % to 90 % point	<1 % of p-p value, with amplitude >50 % of range

**AC Current (Non-Sine Wave)**

Triangle Wave & Truncated Sine Wave Range p-p	Frequency	1-Year Absolute Uncertainty tcal ±5 °C ±(% of output + % of range)	Max Current Resolution
0.047 to 0.92999 mA <sup>[1]</sup>	10 to 45 Hz	0.25 + 0.5	Six digits
	45 Hz to 1 kHz	0.25 + 0.25	
	1 to 10 kHz	10 + 2	
0.93 to 9.29999 mA <sup>[1]</sup>	10 to 45 Hz	0.25 + 0.5	Six digits
	45 Hz to 1 kHz	0.25 + 0.25	
	1 to 10 kHz	10 + 2	
9.3 to 92.9999 mA <sup>[1]</sup>	10 to 45 Hz	0.25 + 0.5	Six digits
	45 Hz to 1 kHz	0.25 + 0.25	
	1 to 10 kHz	10 + 2	
93 to 929.999 mA <sup>[1]</sup>	10 to 45 Hz	0.25 + 0.5	Six digits
	45 Hz to 1 kHz	0.25 + 0.5	
	1 to 10 kHz	10 + 2	
0.93 to 8.49999 A <sup>[2]</sup>	10 to 45 Hz	0.5 + 1.0	Six digits
	45 Hz to 1 kHz	0.5 + 0.5	
	1 to 10 kHz	10 + 2	
8.5 to 57 A <sup>[2]</sup>	45 to 500 Hz	0.5 + 0.5	Six digits
	500 Hz to 1 kHz	1.0 + 1.0	
<p>[1] Frequency limited to 1 kHz with LCOMP on.                  [2] Frequency limited to 440 Hz with LCOMP on.</p>			

**AC Current (Non-Sine Wave) (cont.)**

Square Wave Range p-p	Frequency	1-Year Absolute Uncertainty tcal ±5 °C ±(% of output + % of range)	Max Current Resolution
0.047 to 0.65999 mA <sup>[1]</sup>	10 to 45 Hz	0.25 + 0.5	Six digits
	45 Hz to 1 kHz	0.25 + 0.25	
	1 to 10 kHz	10 + 2	
0.66 to 6.59999 mA <sup>[1]</sup>	10 to 45 Hz	0.25 + 0.5	Six digits
	45 Hz to 1 kHz	0.25 + 0.25	
	1 to 10 kHz	10 + 2	
6.6 to 65.9999 mA <sup>[1]</sup>	10 to 45 Hz	0.25 + 0.5	Six digits
	45 Hz to 1 kHz	0.25 + 0.25	
	1 to 10 kHz	10 + 2	
66 to 659.999 mA <sup>[1]</sup>	10 to 45 Hz	0.25 + 0.5	Six digits
	45 Hz to 1 kHz	0.25 + 0.5	
	1 to 10 kHz	10 + 2	
0.66 to 5.99999 A <sup>[2]</sup>	10 to 45 Hz	0.5 + 1.0	Six digits
	45 Hz to 1 kHz	0.5 + 0.5	
	1 to 10 kHz	10 + 2	
6 to 41 A <sup>[2]</sup>	45 to 500 Hz	0.5 + 0.5	Six digits
	500 Hz to 1 kHz	1.0 + 1.0	
<p>[1] Frequency limited to 1 kHz with LCOMP on. [2] Frequency limited to 440 Hz with LCOMP on.</p>			

**AC Current, Square Wave Characteristics (typical)**

Range	LCOMP	Risetime	Settling Time	Overshoot
I < 6 A @ 400 Hz	off	25 μs	40 μs to 1 % of final value	<10 % for <1 V Compliance
3 A & 20 A Ranges	on	100 μs	200 μs to 1 % of final value	<10 % for <1 V Compliance

**AC Current, Triangle Wave Characteristics (typical)**

Linearity to 400 Hz	Aberrations
0.3 % of p-p value, from 10 % to 90 % point	<1 % of p-p value, with amplitude >50 % of range

# **Chapter 2**

## **Theory of Operation**

<b>Title</b>	<b>Page</b>
Introduction.....	2-3
Encoder Assembly (A2).....	2-3
Synthesized Impedance Assembly (A5) .....	2-4
DDS Assembly (A6).....	2-5
Current Assembly (A7).....	2-6
Voltage Assembly (A8) .....	2-7
Main CPU Assembly (A9).....	2-7
Power Supplies .....	2-8
Outguard Supplies .....	2-8
Inguard Supplies.....	2-8



## Introduction

This chapter gives a description of the analog and digital sections of the Calibrator at a block diagram level. Figure 2-1 shows the configuration of assemblies in the Calibrator. See Chapter 6 for a description of the Oscilloscope Calibration Option.

The Calibrator outputs:

- DC voltage from 0 V to  $\pm 1020$  V.
- AC voltage from 1 mV to 1020 V, with output from 10 Hz to 500 kHz.
- AC current from 29  $\mu$ A to 20.5 A, with variable frequency limits.
- DC current from 0 to  $\pm 20.5$  A.
- Resistance values from a short circuit to 1100 M $\Omega$ .
- Capacitance values from 220 pF to 110 mF.
- Simulated output for eight types of Resistance Temperature Detectors (RTDs).
- Simulated output for eleven types of thermocouples.

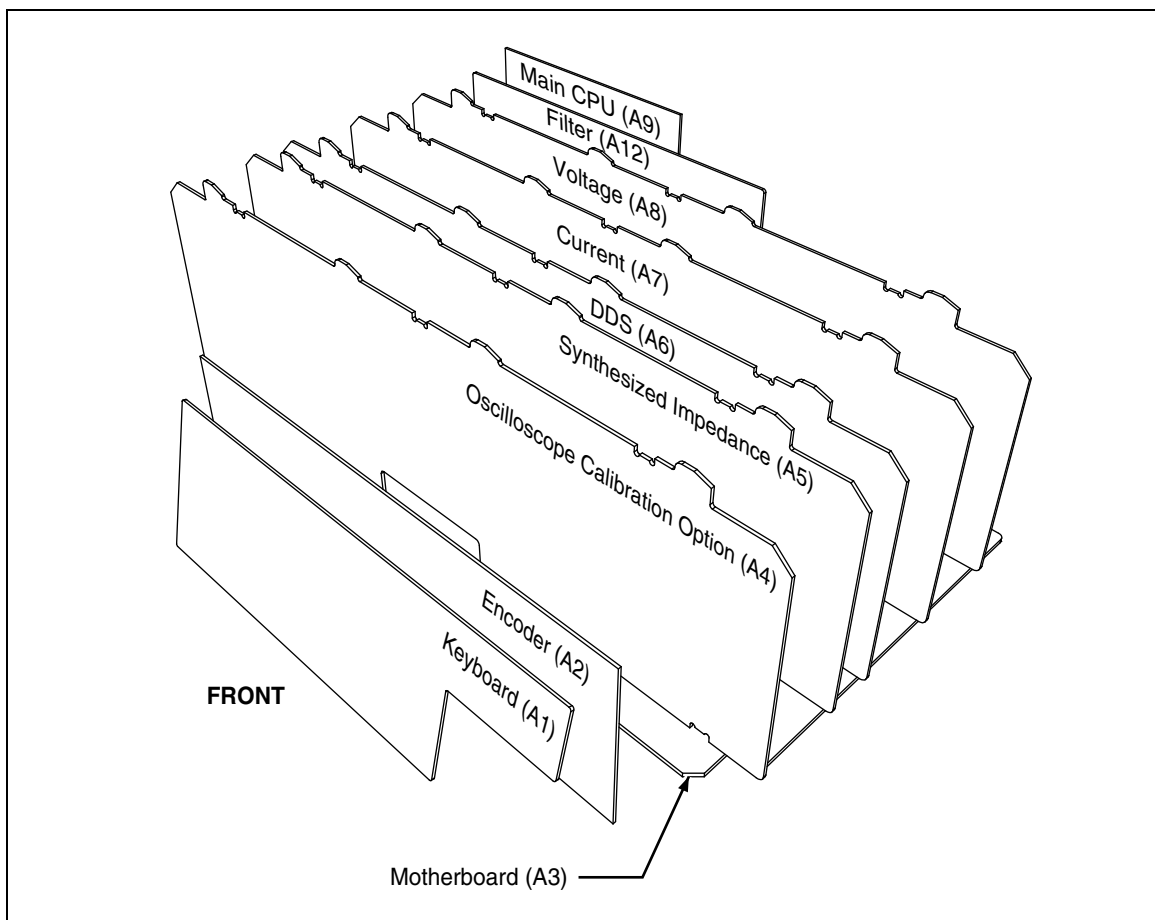

Figure 2-1. 5522A Internal Layout

yg116f.eps

## Encoder PCA (A2)

The Encoder PCA (A2) has its own microprocessor and is in communication with the Main CPU PCA (A9) on the Rear Panel through a serial link. Memory for the Encoder PCA is contained in EPROM. The Encoder PCA is the interface to the Keyboard PCA (A1)

## Synthesized Impedance PCA (A5)

The Synthesized Impedance PCA (A5) supplies variable resistance and capacitance outputs. It uses discrete resistors and capacitors as references, with an amplifier in series. Figure 2-2 is a block diagram of the synthesized resistance function. Figure 2-3 is a block diagram of the synthesized capacitance function.

For resistance synthesis, there is a two-wire compensation circuit, an input amplifier, two DACs (coarse and fine) with offset adjust, and an output LO buffer.

For capacitance synthesis, there is a two-wire compensation circuit, selectable references, an input amplifier, two DACs (coarse and fine), and an output LO buffer.

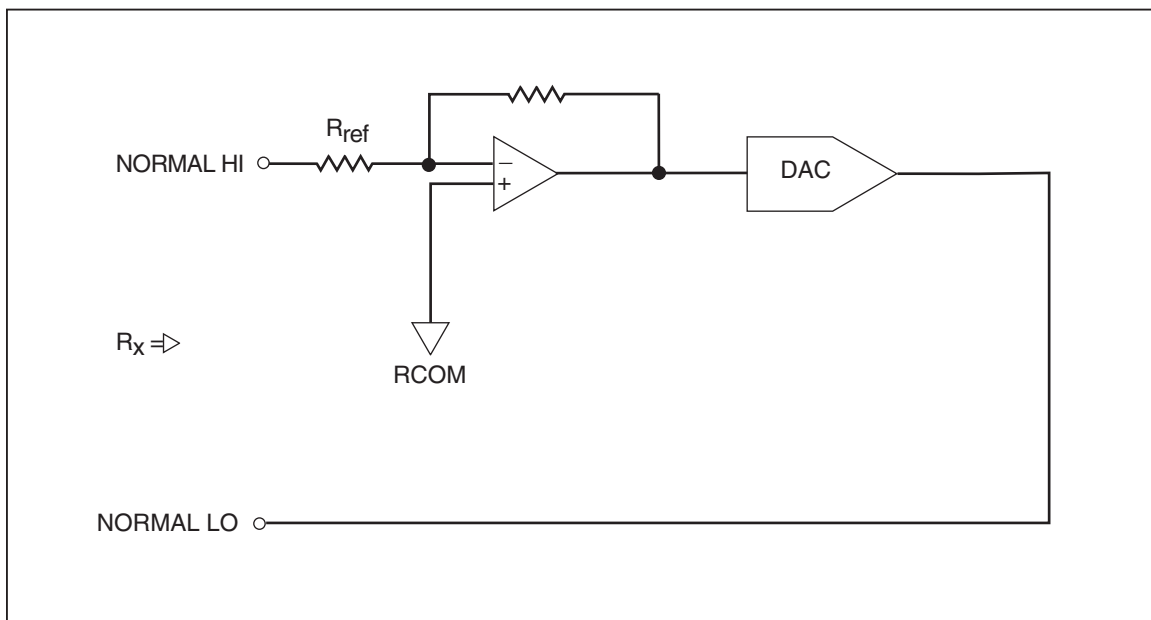

Figure 2-2. Synthesized Resistance Function

yg117f.eps

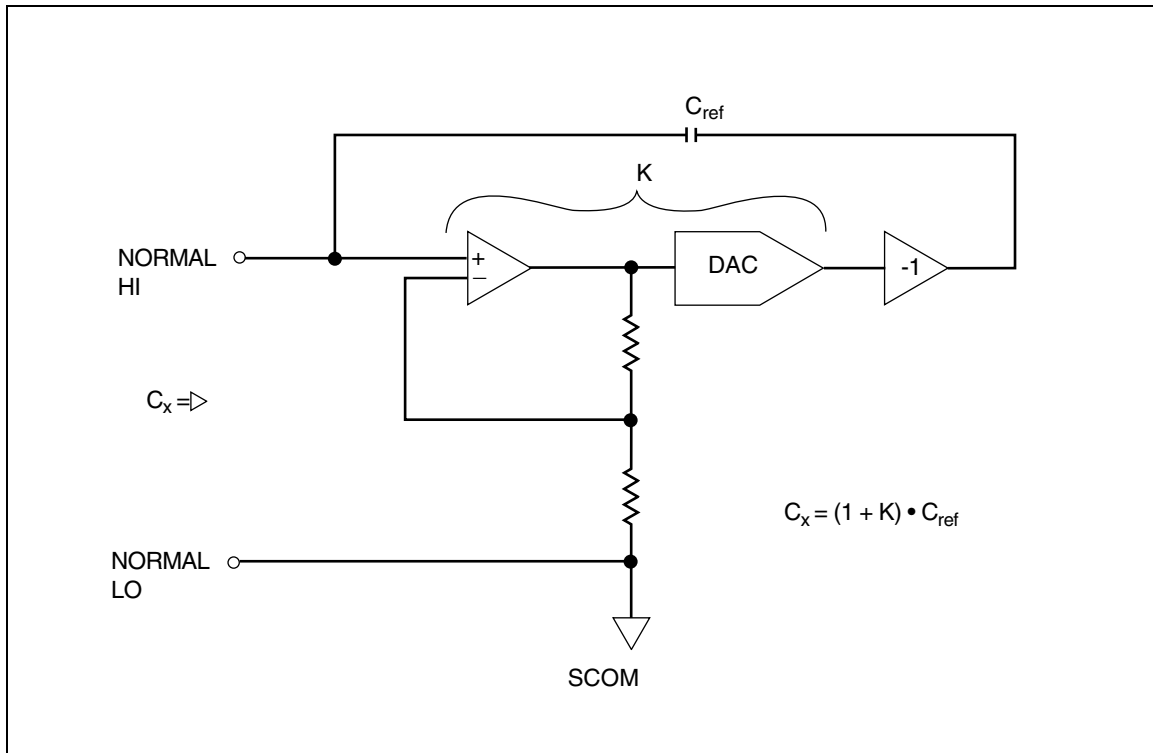

Figure 2-3. Synthesized Capacitance Function

yg118f.eps

## DDS PCA (A6)

The DDS (Direct Digital Synthesis) PCA (A6) has these functional blocks:

- References for all voltage and current functions
- Gain elements for voltage functions and thermocouple measurement and sources
- $\pm 7$  V references
- Thermocouple source and measurement amplifier
- An A/D (Analog-to-Digital) measurement system to monitor all functions
- Self-calibration circuitry
- Zero calibration circuitry
- Precision voltage channel DAC (VDAC)
- Precision current channel DAC (IDAC)
- Dual-channel DDS (Direct Digital Synthesizer)

These functional blocks, when used with the Voltage (A8) and/or Current (A7) assemblies, supply:

- Single or dual channel ac and dc volts, amps, and watts
- Offsettable and nonsinusoidal waveforms
- Duty cycle
- Thermocouple measurement and sourcing
- Internal calibration and diagnostics
- Digital control of all the analog assemblies

DACS are used to control the level of dc signals and to control the amplitude of ac signals.

The dual-channel DDS (Direct Digital Synthesizer) supplies finely stepped digital sine, triangular, and other waveforms.

### Current PCA (A7)

The Current PCA outputs six current ranges (330  $\mu$ A, 3.3 mA, 33 mA, 330 mA, 3 A, and 20 A) and three voltage ranges (330 mV, 3.3 V, and 5 V) to the AUX outputs. The 20 A outputs are sourced through the 20 A AUX binding posts.

The Current PCA connects to the DDS PCA (A6). The Filter PCA (A12) supplies the high current power supplies.

The Current PCA (A7) has these functional blocks:

- A supply that floats.
- Several stages of transconductance amplifier.
- Shunts that sense current and shunt amplifier. (These are the elements that set accuracy.)
- AUX voltage function.

Power for the Current PCA is filtered by the Filter PCA (A12). Its common is isolated from SCOM by a shunt resistor.

Figure 2-4 is a block diagram of the current function. Note that the DDS PCA works together with the Current PCA to supply current outputs.

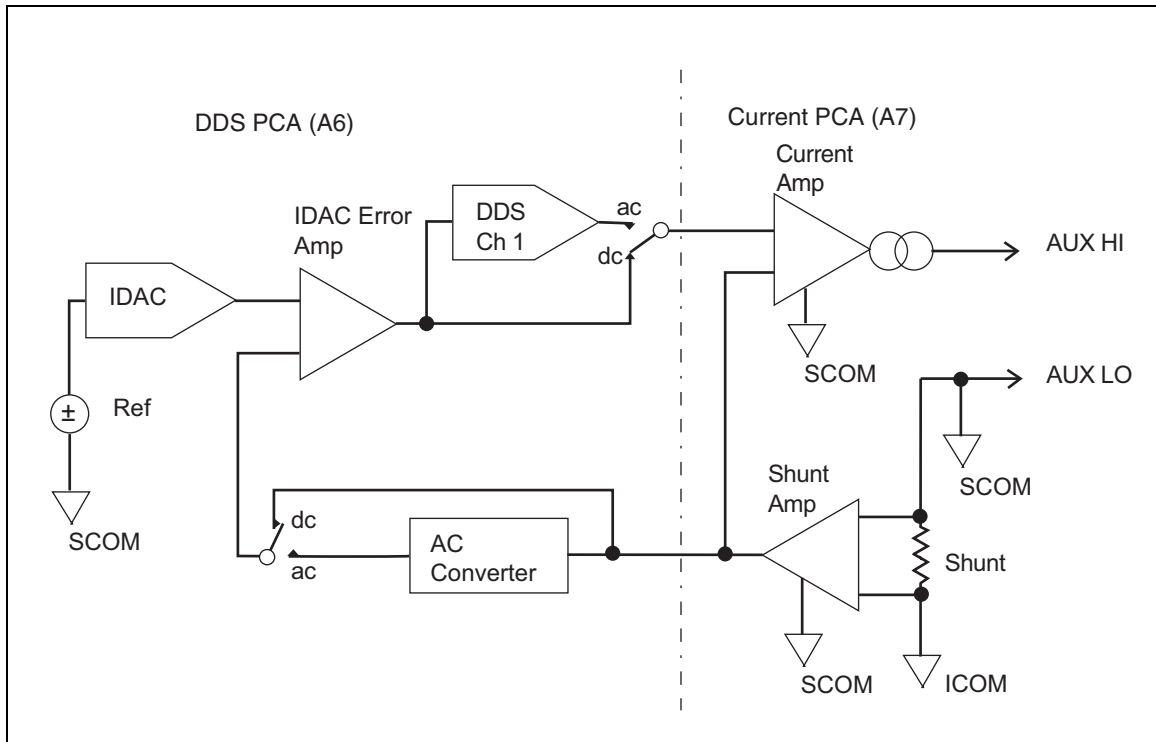

Figure 2-4. Current Function (AUX Out Ranges)

yg119f.eps

## Voltage PCA (A8)

The Voltage PCA (A8) supplies dc and ac voltage outputs in the range 3.3 V and above. It also supplies all the inguard supplies referenced to SCOM. See the “Power Supplies” section.

Figure 2-5 is a block diagram of the voltage function and shows the signal paths for dc and ac voltage outputs. The DAC shown in the figure is VDAC, which resides on the DDS PCA. Note that the voltage amplifier for outputs  $\geq 3.3$  V resides on the Voltage PCA, but the amplifier for voltage outputs  $< 3.3$  V is on the DDS PCA.

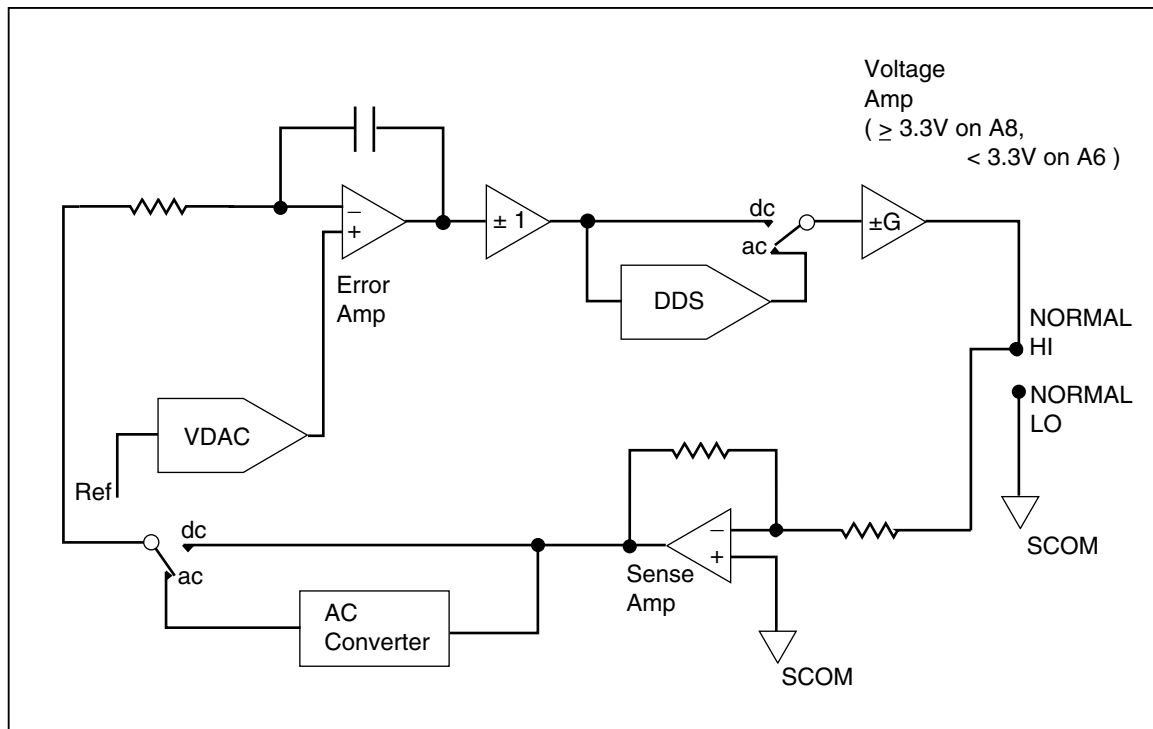

Figure 2-5. Voltage Function

yg120f.eps

## Main CPU PCA (A9)

The Main CPU PCA (A9) attached to the rear-panel assembly communicates with:

- Inguard CPU on the DDS PCA (A6)
- Display assembly CPU
- Serial and IEEE interfaces
- External amplifier (5725A)

The main CPU memory is Flash ROM. There is a real-time clock with a battery backup.

Each analog assembly has the same bus structure:

- One or more Chip Select lines
- Common data bus that connects to the motherboard, latched in by latches
- A fault line that sets all modules to a safe condition if a malfunction is found

The routing of signals to the front panel jacks are controlled by output relays on the motherboard.

## **Power Supplies**

AC line voltage is applied through a line filter to a power module in the rear panel. The module switches to accommodate four line voltages. The outputs of the power module are attached directly to the primaries of the mains transformer. The safety ground wire is attached from the power module to the rear panel.

Major internal grounds are SCOM, which is attached to OUTPUT LO and the guard shell, ICOM, which is the internal ground for the current function, and GCOM, which is the outguard common and is attached to earth ground.

## **Outguard Supplies**

The motherboard supplies the outguard power supplies: +12VG, -12VG, and +5VG. All the transformer connections for the outguard supplies come through one bundle of wires connected to the motherboard with P1. A row of test points in front of the fan lets you to connect to the raw and regulated supplies. The outguard supplies are used only by the CPU PCA (A9) and Encoder PCA (A2).

## **Inguard Supplies**

The inguard supplies are put on the Voltage PCA (A8). The mains transformer connections (inguard SCOM referenced) are connected to the Motherboard (A3). Current protection devices for each of the supplies are put on the Motherboard. It is unlikely these devices will blow unless there is a second fault since the regulators will limit current below the device ratings.

Filter capacitors for the high-current supply for the Current PCA (A7) are put on the Filter PCA (A12).

The inguard SCOM referenced supplies are +15 V, -15 V, +5 V, -5 V, and +5RLH. The +5 V and +5RLH supplies share the same raw supply. The +5RLH supply is used exclusively as a relay driver and is nominally approximately 6.3 V. Test points for these supplies are put in a row across the top of the Voltage PCA. The 65 V supplies are rectified and filtered on the motherboard but regulated on the Voltage PCA (A8).

# Chapter 3

## Calibration and Verification

Title	Page
Introduction.....	3-3
Equipment Necessary for Calibration and Verification.....	3-3
Calibration .....	3-4
Start Calibration.....	3-5
DC Volts Calibration (NORMAL Output).....	3-5
DC Volts Calibration (30 V dc and Above).....	3-6
AC Volts Calibration (NORMAL Output).....	3-7
Thermocouple Function Calibration.....	3-9
DC Current Calibration .....	3-10
AC Current Calibration .....	3-13
DC Volts Calibration (AUX Output).....	3-19
AC Volts Calibration (AUX Output).....	3-19
Resistance Calibration .....	3-20
Capacitance Calibration.....	3-22
Calibration Remote Commands.....	3-24
How to Make a Calibration Report.....	3-30
Performance Verification Tests .....	3-31
How to Zero the Calibrator.....	3-31
DC Volts Verification (NORMAL Output).....	3-31
DC Volts Verification (AUX Output).....	3-32
DC Current Verification .....	3-33
Resistance Verification.....	3-34
AC Voltage Verification (NORMAL Output).....	3-35
AC Voltage Verification (AUX Output) .....	3-37
AC Current Verification .....	3-38
Capacitance Verification .....	3-41
200 $\mu$ F to 110 mF Capacitance Verification .....	3-43
Capacitance Measurement.....	3-43
Measurement Uncertainty .....	3-47
Thermocouple Simulation Verification (Sourcing).....	3-47
Thermocouple Measurement Verification.....	3-48
Phase Accuracy Verification, Volts and AUX Volts.....	3-48
Phase Accuracy Verification, Volts and Current.....	3-49
Frequency Accuracy Verification.....	3-50



## Introduction

Calibrate the Calibrator at the end of a 90 day or 1 year calibration interval. If you recalibrate on a 90 day interval, use the 90 day specifications, which gives higher performance. Use the verification procedure or a section of the procedure when it becomes necessary to make sure that the Calibrator does operate to its specifications.

Fluke recommends that you send the Calibrator to Fluke for calibration and verification. The Fluke Service Center uses a software-controlled verification procedure and supplies a test report that includes traceability to national standards. If you plan to calibrate or do a verification of the Calibrator at your site, use this chapter as a guide. The procedures in this chapter are manual versions of the software-controlled procedure used at the Fluke Service Center.

## Equipment Necessary for Calibration and Verification

Table 3-1 is a list of necessary equipment to calibrate and do a verification of the performance of the Calibrator. If a specified instrument is not available, you can use an equivalent instrument that has the same or better performance.

**Table 3-1. Consolidated List of Required Equipment for Calibration and Verification**

Qty	Manufacturer	Model	Equipment	Purpose
1	Fluke	5500A/LEADS	Test lead set	All functions
1	Fluke	8508A	Reference Multimeter	DC voltage, dc current, resistance, thermocouple measurement and sourcing
1	Fluke	752A	Reference Divider 100:1, 10:1	DC voltage
1	Keithley	155	Null Detector	DC voltage (calibrate Fluke 752A for dc voltage)
1	Fluke	742A-1k	Resistance Standard, 1 k $\Omega$	DC current
1	Fluke	742A-100	Resistance Standard, 100 $\Omega$	DC current
1	Fluke	742A-10	Resistance Standard, 10 $\Omega$	DC current
1	Fluke	742A-1	Resistance Standard, 1 $\Omega$	DC current
1	Guildline	9230	0.1 $\Omega$ shunt	DC current, verification procedure only
1	Guildline	9230	0.01 $\Omega$ shunt	DC current
1	Fluke	742A-1M	Resistance Standard, 1 M $\Omega$	Resistance
1	Fluke	742A-10 M	Resistance Standard, 10 M $\Omega$	Resistance
1	Guildline	9334/100 M	Resistance Standard, 100 M $\Omega$	Resistance
1	Guildline	9334/1G	Resistance Standard, 1G $\Omega$	Resistance
1	Fluke	PN 900394	Type N to dual banana adapter	AC voltage
1	Fluke	5790A	AC Measurement Standard	AC voltage, ac current
1	Fluke	A40	10 mA, 20 mA, 200 mA, 2 A current shunts	AC current

Table 3-1. Consolidated List of Required Equipment for Calibration and Verification (cont.)

Qty	Manufacturer	Model	Equipment	Purpose
1	Fluke	A40A	20 A current shunt	AC current
1	Fluke	792A-7004	A40 Current Shunt Adapter	AC current
1	various	metal film resistors	1 k $\Omega$ , 200 $\Omega$	AC current
1	Fluke	PM 9540/BAN	Cable Set	Capacitance
1	Fluke	PM 6304C	LCR Meter	Capacitance
1	Fluke	5700A	Calibrator	Precision current source for ac/dc current transfers, and to use in conjunction with an Fluke 8508A DMM for thermocouple measurement function
1	ASTM	56 C	Mercury thermometer	Thermocouple measurement
1	various	various	Dewar flask and cap, mineral oil lag bath	Thermocouple measurement
1	North Atlantic Or Clarke-Hess	2000  6000	Precision Phase Meter <sup>[1]</sup>	Phase
1	Fluke	PN 690567	Fluke resistor network used as a shunt, 0.01 $\Omega$ , 0.09 $\Omega$ , 0.9 $\Omega$ values needed	Phase
1	Hewlett-Packard	3458A	Digital Multimeter	Capacitance
1	Fluke	6680B	Frequency Counter	Frequency
[1] If desired, the test uncertainty ratio (TUR) can be improved by characterizing the phase meter with a primary phase standard like the Clarke-Hess 5500 before use.				

## Calibration

The standard Calibrator has no internal hardware adjustments. Oscilloscope options have hardware adjustments. See Chapter 6. The Control Display steps you through the calibration procedure. Calibration occurs in these steps:

1. The Calibrator sources output values and you measure the outputs with a traceable measurement instrument of higher accuracy. The Calibrator automatically sets the outputs and instructs you to make external connections to applicable measurement instruments.
2. At each measure and enter step, you can push the OPTIONS, and BACK UP STEP softkeys to redo a step, or SKIP STEP to skip over a step.
3. You can type in the measured results through the front panel keyboard or remotely with an external terminal or computer.

*Note*

*Intermixed with the “output and measure” procedures are internal 5520A calibration procedures where operator input is not necessary.*

4. The Calibrator calculates a software correction factor and puts it in volatile memory.
5. When the calibration procedure is complete, you are instructed to put all the correction factors in nonvolatile memory or discard them and start again.

For most calibration procedures, the frequency and phase steps are not necessary. All the calibration steps are available from the front panel interface and the remote interface (IEEE-488 or serial). Frequency and phase calibration are recommended after instrument repair, and are available only through the remote interface (IEEE-488 or serial). See the “Calibration Remote Commands” section to learn more about calibration through the remote interface.

**Start Calibration**

From the front panel, push the **SETUP** key, followed by the **CAL** softkey twice, and then the **5522A CAL** softkey. The CALIBRATION SWITCH on the rear panel can be in the ENABLE or NORMAL position when you begin calibration. It must be set to ENABLE to store the correction factors into nonvolatile memory.

You start a calibration procedure when you push the **5522A CAL** softkey. From this point:

1. The Calibrator automatically sets the outputs and prompts you to make external connections to applicable measurement instruments.
2. The Calibrator then goes into Operate mode, or instructs you to put it into Operate mode.
3. You are then instructed to type in the value read on the measurement instrument.

*Note*

*At each measure and enter step, to do a step again, push the **OPTIONS**, and **BACK UP STEP** softkey, or skip a step with the **SKIP STEP** softkey.*

**DC Volts Calibration (NORMAL Output)**

Table 3-2 is a list of equipment necessary to calibrate the dc volts function. (The equipment is also shown in the consolidated table, Table 3-1).

**Table 3-2. Test Equipment Required for DC Volts Calibration**

Qty	Manufacturer	Model	Equipment
1	Fluke	5500A/LEADS	Test lead set
1	Fluke	8508A	Reference Multimeter
1	Fluke	752A	Reference Divider
1	Keithley	155	Null Detector

To calibrate the dc voltage function:

1. On the Fluke 8508A put a 4-wire short (Fluke PN 2540973) across the HI and LO input and sense terminals.
2. Push DCV, then INPUT, and then ZERO FUNC. Allow the zero function to finish.
3. Make sure that the UUT (Unit Under Test) is in Standby.
4. Start the Calibrator calibration as instructed in the “Start Calibration” section.

5. Do an internal DC Zeros Calibration as instructed.
6. Connect the test equipment as shown in Figure 3-1.
7. Measure and type in the values into the UUT for steps 1 through 6 in Table 3-3 as instructed. You will disconnect and reconnect the reference multimeter as instructed in these steps.
8. Make sure that the UUT is in Standby.
9. Connect the reference multimeter and Reference Divider to the UUT as shown in Figure 3-1.
10. For voltages 30 V dc and above, see the subsequent section.

**Table 3-3. Calibration Steps for DC Volts**

Step	Calibrator Output (NORMAL)
1	1.000000 V
2	3.000000 V
3	-1.000000 V
4	-3.000000 V
5	0.0000 mV
6	300.0000 mV
7	30.00000 V
8	300.0000 V
9	1000.000 V

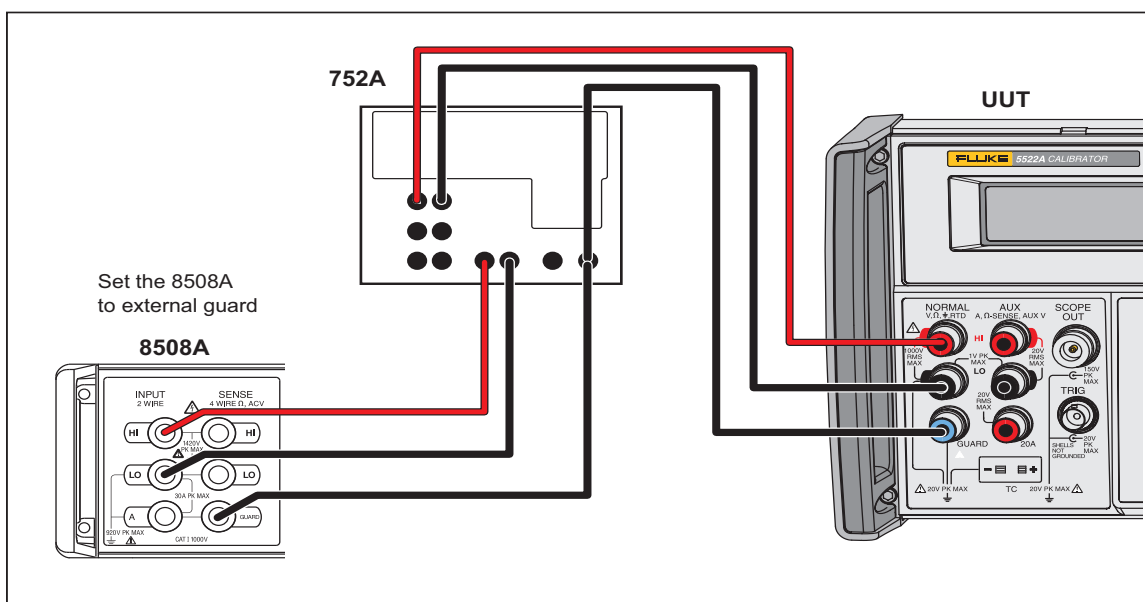

**Figure 3-1. DC Volts Calibration Connections up to 30 V**

gjh115.eps

**DC Volts Calibration (30 V dc and Above)**

To calibrate the dc voltage function (30 Vdc and above):



- Type in the measured values into the Calibrator for each step in Table 3-5 as instructed.

Table 3-5. AC Volts Calibration Steps

Steps	5522A Output (NORMAL)	
	Amplitude	Frequency
1	3.29990 V	100.00 Hz
2	0.33000 V	100.00 Hz
3	3.00000 V	500.0 kHz
4	3.0 V	9.99 Hz
5	30.000 mV	100.00 Hz
6	300.000 mV	100.00 Hz
7	300.000 mV	500.0 kHz
8	30.0000 V	100.00 Hz
9	300.000 V	70.00 kHz
10	1000.00 V	100.00 Hz
11	1000.00 V	7.000 kHz

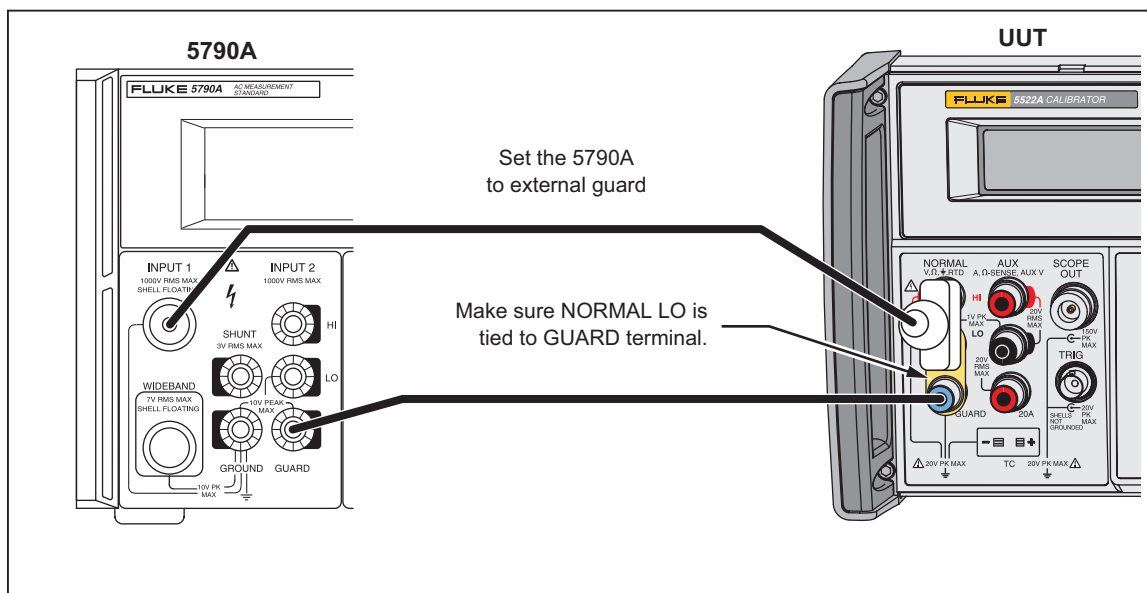

Figure 3-3. AC Volts Calibration Connections

gjh116.eps

**Thermocouple Function Calibration**

Table 3-6 is a list of equipment necessary to calibrate the thermocouple measure and source functions. (The equipment is also shown in the consolidated table, Table 3-1.)

**Table 3-6. Test Equipment Necessary for Thermocouple Function Calibration**

Qty	Manufacturer	Model	Equipment
1	Fluke	5520A/LEADS	Test lead set (includes Type-J thermocouple, wire, and mini plug)
4 feet	various	various	24-gauge solid copper telephone wire
1	ASTM	56C	Mercury thermometer
1	various	various	Dewar flask and cap, mineral oil lag bath
1	Fluke	8508A	Reference Multimeter

To calibrate the thermocouple function:

1. Make sure that the UUT is in standby.
2. With no connections to the UUT terminals, push the **GO ON** softkey as instructed to start TC calibration. Let the internal calibration steps complete.
3. Connect the 8508A to the TC terminals with solid copper telephone wire and a copper (uncompensated) TC miniplug as shown in Figure 3-4. Attach the wires directly to the Reference Multimeter binding posts. Set the Reference Multimeter to read dc millivolts.
4. Type the measured value into the UUT for step 1 in Table 3-7 as instructed.
5. Disconnect the test equipment.
6. Connect a Type-J thermocouple to the TC terminals on the UUT. Put the thermocouple and a precision mercury thermometer fully in to a mineral oil lag bath that is  $\pm 2$  °C of ambient temperature. The test setup is shown in Figure 3-5.
7. Let the temperature measurement become stable for a minimum of 3 minute, then read the temperature on the mercury thermometer and type it into the UUT.

**Table 3-7. Thermocouple Measurement Calibration Steps**

Step	5522A Output (AUX HI, LO)
1	300 mV dc (NORMAL)
2	Enter temperature read from mercury thermometer as prompted

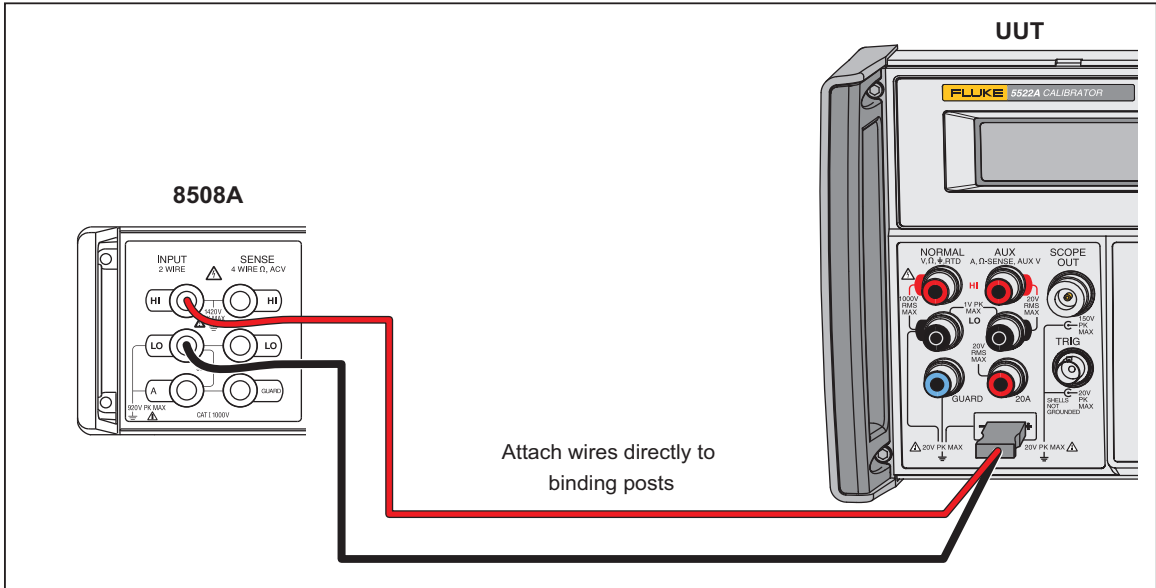

Figure 3-4. Thermocouple Source Calibration Connections

gjh117.eps

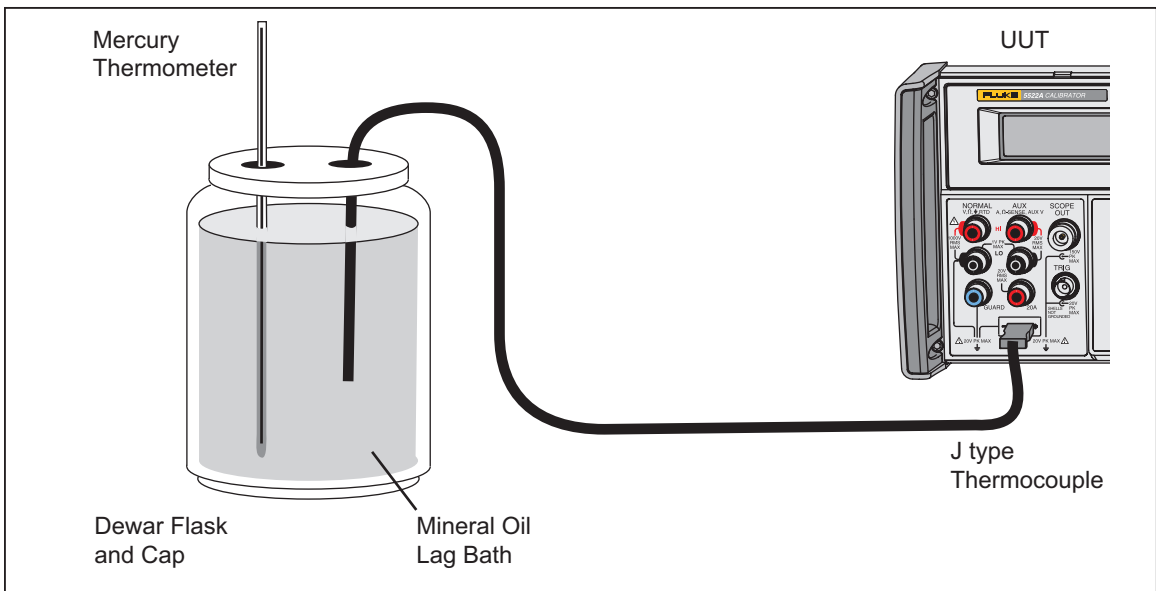

Figure 3-5. Thermocouple Measure Calibration Connections

gjh101.eps

### DC Current Calibration

Table 3-8 is a list of equipment necessary to calibrate the dc current function. (The equipment is also listed in Table 3-1.)

You must use the calibrated dc current function of the Calibrator later to prepare for ac calibration. Because of this, you must save the dc current constants after dc current calibration and exit calibration, then resume calibration. This dc current calibration procedure shows how to save, exit, and resume calibration.

**Table 3-8. Test Equipment Necessary for DC Current Calibration**

Qty	Manufacturer	Model	Equipment
1	Fluke	5500A/LEADS	Test lead set
1	Fluke	8508A	Reference Multimeter
1	Fluke	742A-1k	Resistance Standard, 1 kΩ
1	Fluke	742A-100	Resistance Standard, 100 Ω
1	Fluke	742A-10	Resistance Standard, 10 Ω
1	Fluke	742A-1	Resistance Standard, 1 Ω
1	Guildline	9230	0.01 Ω shunt

To calibrate the dc current function:

1. On the Fluke 8508A put a 4-wire short (Fluke PN 2540973) across the HI and LO input and sense terminals.
2. Push DCV, then INPUT, and then ZERO FUNC. Allow the zero function to finish.
3. Make sure that the UUT is in standby.
4. Set the 8508A to measure dc voltage.
5. Connect the 8508A and 742A-1k Resistance Standard to the UUT as shown in Figure 3-6.
6. On the first dc current calibration point in Table 3-9, let the output become stable, record the 8508A voltage measurement, and compute the UUT current output with the certified resistance value of the 742A.
7. Type in the calculated value into the UUT.
8. Continue to the subsequent calibration point, make sure that the UUT is in standby, and disconnect the 742A.
9. Do steps 3 through 6 again with the resistance standard or current shunt specified for each calibration point in Table 3-9.
10. Exit calibration and save the calibration constants that were changed so far with the front panel menus or the CAL\_STORE remote command.

**Table 3-9. DC Current Calibration Steps**

Step	5522A Output (AUX HI, LO)	Shunt to Use
1	300.000 μA	Fluke 742A-1k 1 kΩ Resistance Standard
2	3.00000 mA	Fluke 742A-100 100 Ω Resistance Standard
3	30.000 mA	Fluke 742A-10 10 Ω Resistance Standard
4	300.000 mA	Fluke 742A-1 1 Ω Resistance Standard
5	2.00000 A	Guildline 9230 0.01 Ω shunt
	<b>20A, LO</b>	
6	10.0000 A	Guildline 9230 0.01 Ω shunt

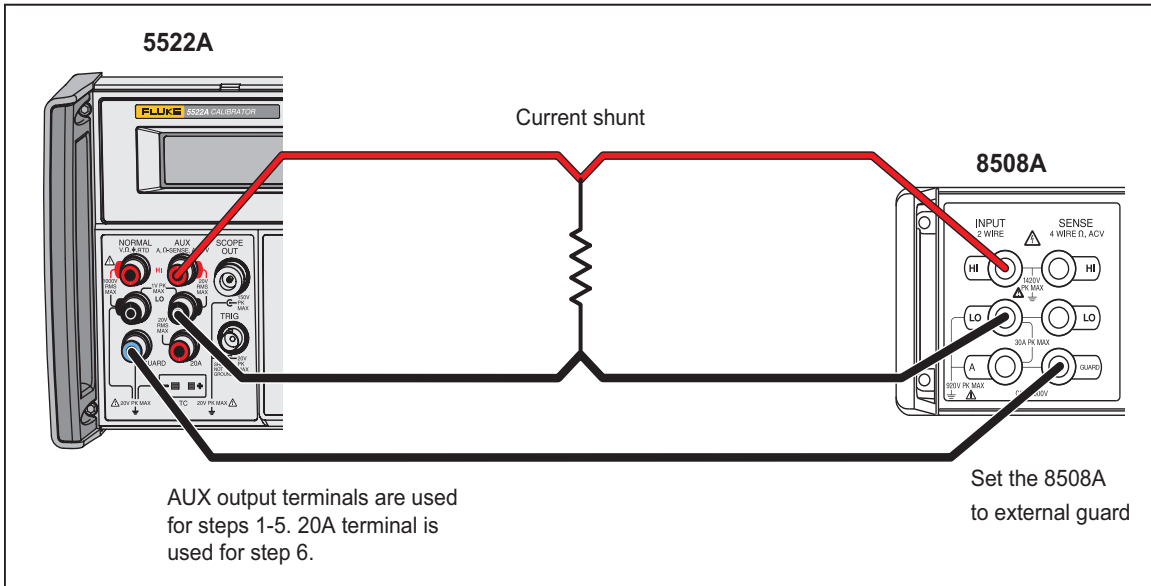

Figure 3-6. DC Current Calibration Connections

## AC Current Calibration

### Note

*DC current must be calibrated before you do the ac current calibration.*

The ac current calibration uses a number of current shunts that must be dc characterized before they can be used. You can do the dc characterization with the Calibrator, but you must do the complete Calibrator dc current calibration first. In the dc characterization procedure, data is collected for each of the ac current levels that is necessary for the ac current calibration procedure. For example, if a shunt is used for 0.33 mA ac and 3.3 mA ac calibrations, you must get data at .33 mA dc and 3.3 mA dc.

Follow these steps to characterize the shunt:

Connect the test equipment as shown in Figure 3-7.

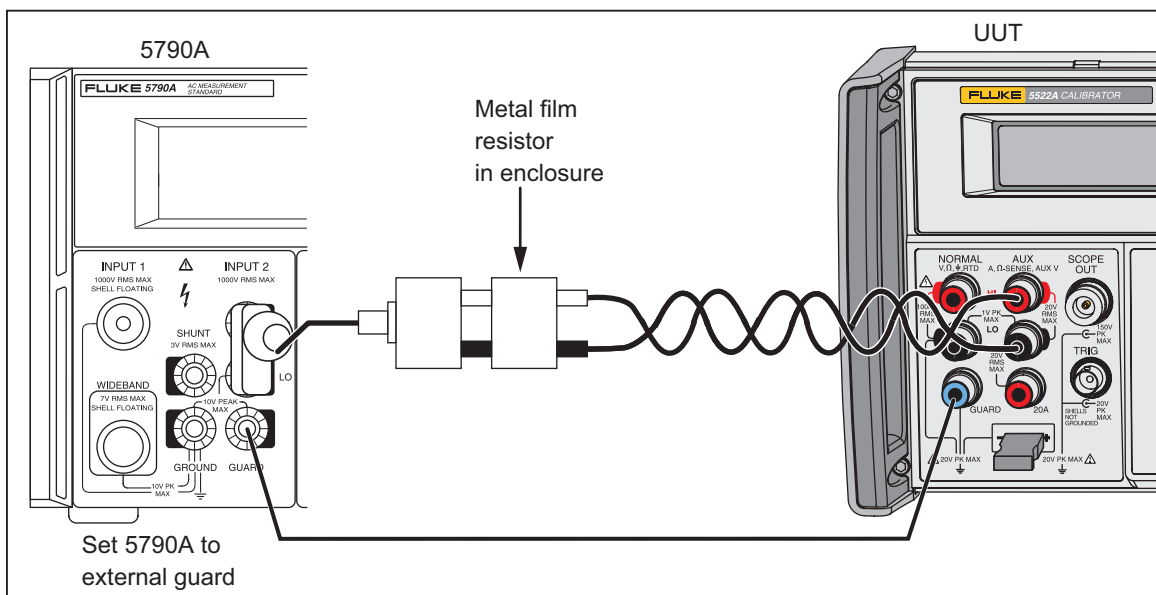

**Figure 3-7. AC Current Calibration with Fluke A40 Shunt Connections**

For each amplitude shown in Table 3-11, apply the equivalent +(positive) and -(negative) dc current from the Calibrator.

Calculate the actual dc characterization value with this formula:

$$\frac{((+ \text{ value}) - (- \text{ value}))}{2}$$

The time between the dc characterization of a current shunt and its use in the calibration procedure must be kept to a minimum. To decrease this time, each shunt is characterized immediately before you use it. As the ac current calibration procedure is done, it must be temporarily aborted each time a new shunt value is necessary. After the shunt is characterized, the calibration procedure is continued at the point immediately before.

An example of this procedure:

1. Do the dc current calibration procedure.
2. In Table 3-11, select the first current shunt (A40-10 mA)
3. Do a dc characterization of the shunt at the amplitude specified in the table (as demonstrated above).
4. Do the ac current calibration procedure again and push the SKIP STEP softkey to go

to the step(s) where shunt characterization is necessary.

5. Set the Calibrator to OPERATE and measure the ac voltage across the shunt.
6. Use the data collected in the dc characterization with the ac correction factors supplied for the shunt by the manufacturer to calculate the ac current. Type this value into the calibrator.
7. Continue this procedure until you do all the steps in Table 3-11.

Some of the important remote commands used in this procedure are:

- CAL\_START MAIN, AI      Start the ac current calibration procedure.
- CAL\_SKIP                      Skip to the appropriate calibration step.
- CAL\_ABORT                    Used to exit calibration between steps.
- CAL\_NEXT                    Perform the next calibration step.
- CAL\_STORE                    Store the new calibration constants

Because of the complexity of this procedure, it is recommended that the procedure be automated. See Figure 3-9 for a MET/CAL code fragment that demonstrates an automated calibration procedure.

Table 3-10 is a list of equipment necessary to calibrate the ac current function. (The equipment is also shown in the Table 3-1.) Refer to Figure 3-8 for the equipment connections.

**Table 3-10. Test Equipment Necessary for AC Current Calibration**

Qty	Manufacturer	Model	Equipment
1	Fluke	5500A/LEADS	Test lead set
1	Fluke	PN 900394	Type N to dual banana adapter
1	Fluke	5790A	AC Measurement Standard
1	Fluke	A40-10 mA	Current Shunt, 10 mA
1	Fluke	A40-200 mA	Current Shunt, 200 mA
1	Fluke	A40-2A	Current Shunt, 2 A
1	Fluke	A40A-20A	Current Shunt, 20 A
1	Fluke	792A-7004	A40 Current Shunt Adapter

**Table 3-11. AC Current Calibration Steps**

Steps	5522A Output (AUX HI, LO)		
	Amplitude	Frequency	Shunt to Use
1	3.29990 mA	100.00 Hz	Fluke A40 10 mA
2	0.33000 mA	100.00 Hz	Fluke A40 10 mA
3	3.00000 mA	10.00 kHz	Fluke A40 10 mA
4	3.00000 mA	30.000 kHz	Fluke A40 10 mA
5	0.30000 mA	100.00 Hz	Fluke A40 10 mA
6	0.30000 mA	10.00 kHz	Fluke A40 10 mA

**Table 3-11. AC Current Calibration Steps (cont.)**

Steps	5522A Output (AUX HI, LO)		
	Amplitude	Frequency	Shunt to Use
7	0.30000 mA	30.00 kHz	Fluke A40 10 mA
8	30.0000 mA	100.00 Hz	Fluke A40 200 mA
9	30.0000 mA	10.00 kHz	Fluke A40 200 mA
10	30.0000 mA	30.00 kHz	Fluke A40 200 mA
11	300.000 mA	100.00 Hz	Fluke A40 2 A
12	300.000 mA	10.00 kHz	Fluke A40 2 A
13	300.000 mA	30.00 kHz	Fluke A40 2 A
14	2.00000 A	100.00 Hz	Fluke A40 2 A
15	2.00000 A	1000.0 Hz	Fluke A40 2 A
16	2.00000 A	5000.0 Hz	Fluke A40 2 A
17	2.00000 A	60.00 Hz	Fluke A40 2 A
18	2.00000 A	100.00 Hz	Fluke A40 2 A
19	2.00000 A	440.00 Hz	Fluke A40 2 A
<b>AUX 20A, LO</b>			
20	10.0000 A	100.00 Hz	Fluke A40A 20 A
21	10.0000 A	500.00 Hz	Fluke A40A 20 A
22	10.0000 A	1000.00 Hz	Fluke A40A 20 A
23	10.0000 A	60.00 Hz	Fluke A40A 20 A
24	10.0000 A	100.00 Hz	Fluke A40A 20 A
25	10.0000 A	440.00 Hz	Fluke A40A 20 A

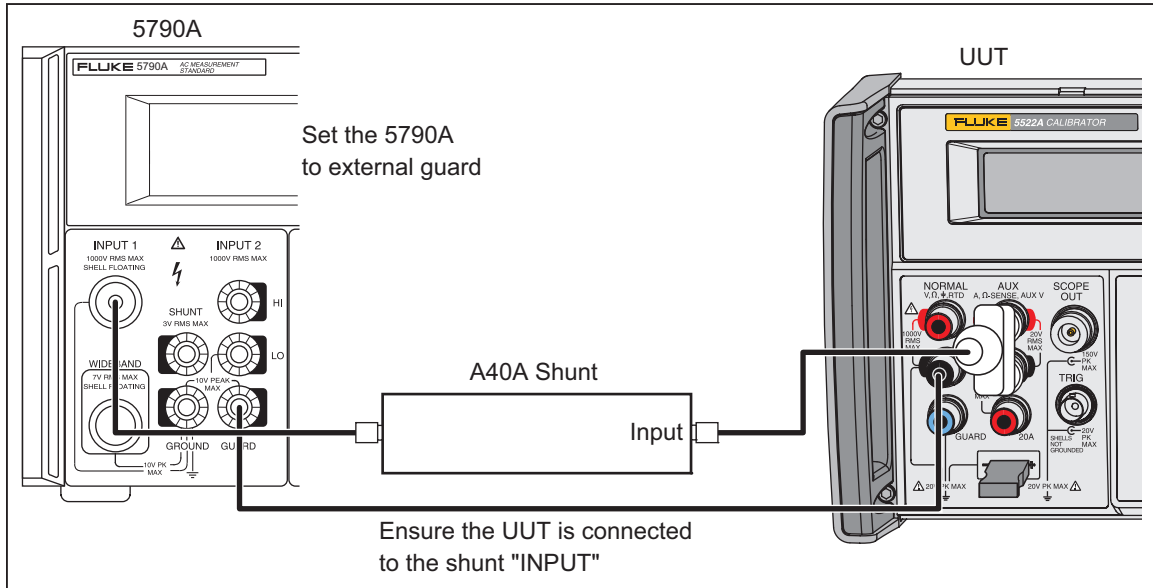

Figure 3-8. AC Current Calibration with Fluke A40A Shunt Connection

gjh131.eps

```

Fluke Corporation - Worldwide Support Center MET/CAL Procedure
=====
INSTRUMENT:          Sub Fluke 5520A ACI ADJ
DATE:                22-Sep-98
AUTHOR:              Gary Bennett, Metrology Specialist
REVISION:            0.6
ADJUSTMENT THRESHOLD: 70%
NUMBER OF TESTS:     1
NUMBER OF LINES:     487
CONFIGURATION:       Fluke 5790A
=====
STEP   FSC   RANGE NOMINAL      TOLERANCE   MOD1      MOD2  3  4 CON
# 10 Sep 98 changed Cal_Info? commands to Out? and checked for 10A -
# needs cal_next to get past display; check for 0 out when ACI is done.
#
  1.001 ASK-   R   Q N                U       C       F       W

  1.002 HEAD          AC CURRENT ADJUSTMENT
# Set M[10] to 3mA initially
  1.003 MATH          M[10] = 0.003
# Reset UUT - get it out of calibration mode.
  1.004 IEEEE          *CLS;*RST; *OPC?[I]
  1.005 IEEEE          ERR?[I$] [GTL]
  1.006 MATH          MEM1 = FLD(MEM2,1,"")
  1.007 JMPT
  1.008 IEEEE          CAL_SW?[I] [GTL]
  1.009 MEME
  1.010 JMPZ          1.012
  1.011 JMP           1.015
  1.012 HEAD          WARNING! CALIBRATION SWITCH IS NOT ENABLED.
  1.013 DISP          The UUT CALIBRATION switch is in NORMAL.
  1.013 DISP
  1.013 DISP          The switch MUST be in ENABLE to store the
  1.013 DISP          new calibration constants.
  1.013 DISP
  1.013 DISP          Select ENABLE, then press "Advance" to
  1.013 DISP          continue with the calibration process.
  1.014 JMP           1.008

# Reset 5790A standard.
  1.015 ACMS          *
  1.016 5790          *                               S
  1.017 HEAD          DCI References
  1.018 PIC           552A410m
  1.019 IEEEE          OUT 3.2999mA, 0HZ; OPER; *OPC?[I] [GTL]
  1.020 IEEEE          [D30000] [GTL]

  1.021 ACMS          G

  1.022 5790          A                               SH   N 2W
    
```

Figure 3-9. Sample MET/CAL Program

```

1.023 MATH          M[17] = MEM
# Apply nominal -DC Current to A40
1.024 IIEEE        OUT -3.2999mA, 0HZ; OPER; *OPC?[I] [GTL]
1.025 IIEEE        [D5000] [GTL]
1.026 ACMS                G
1.027 5790          A          SH      N  2W
1.028 MATH          M[17] = (ABS(MEM) + M[17]) / 2

1.029 IIEEE        OUT .33mA, 0HZ; OPER; *OPC?[I] [GTL]
1.030 IIEEE        [D15000] [GTL]
1.031 ACMS                G
1.032 5790          A          SH      N  2W
1.033 MATH          M[18] = MEM
# Apply nominal -DC Current to A40
1.034 IIEEE        OUT -.33mA, 0HZ; OPER; *OPC?[I] [GTL]
1.035 IIEEE        [D5000] [GTL]
1.036 ACMS                G
1.037 5790          A          SH      N  2W
1.038 MATH          M[18] = (ABS(MEM) + M[18]) / 2

1.039 IIEEE        OUT 3mA, 0HZ; OPER; *OPC?[I] [GTL]
1.040 IIEEE        [D15000] [GTL]
1.041 ACMS                G
1.042 5790          A          SH      N  2W
1.043 MATH          M[19] = MEM
# Apply nominal -DC Current to A40
1.044 IIEEE        OUT -3mA, 0HZ; OPER; *OPC?[I] [GTL]
1.045 IIEEE        [D5000] [GTL]
1.046 ACMS                G
1.047 5790          A          SH      N  2W
1.048 MATH          M[19] = (ABS(MEM) + M[19]) / 2
1.049 IIEEE        CAL_START MAIN,AI; *OPC?[I] [GTL]
1.050 IIEEE        CAL_NEXT; *OPC?[I] [GTL]
1.051 HEAD          Calibrating 3.2999mA @ 100Hz
# cal_next is required for initial start.
# after sending AIG330U if you send cal_next 5520A tries to
# start the cal at that time.

# 3.2999mA @ 100Hz
1.052 IIEEE        *CLS;OPER; *OPC?[I] [GTL]
1.053 IIEEE        [D5000] [GTL]
1.054 ACMS                G
1.055 5790          A          SH      N  2W

# Calculate difference between the average value of both polarities of DC
# Current and the applied AC Current.
1.056 MATH          M[21] = 0.0032999 - (.0032999 * (1 - (MEM / M[17])))

```

Figure 3-9. Sample MET/CAL Program (cont.)

```
# Determine measurement frequency to retrieve correct AC-DC difference value.
1.057 IEEE          OUT?[I$] [GTL]
1.058 MATH          M[2] = FLD(MEM2,5,"")
# Retrieve AC-DC difference from data file named "A40-10mA"
1.059 DOS           get_acdc A40-10mA
1.060 JMP           1.064
1.061 OPBR          An error occurred during get_acdc
1.061 OPBR          Press YES to try again or NO to terminate.
1.062 JMP           1.059
1.063 JMP           1.231

# Correct the calculated value of AC Current by adding the AC-DC difference
# of the A40-series shunt used at the frequency under test
1.064 MATH          MEM = (M[21] * MEM) + M[21]
# Store corrected value into the UUT
1.065 IEEE          CAL_NEXT [MEM]; *OPC? [I] [GTL]
1.066 IEEE          ERR? [I$] [GTL]
1.067 MATH          MEM1 = FLD(MEM2,1,"")
1.068 JMP           1.231
# 'Ask' UUT for next value to calibrate
1.069 IEEE          CAL_REF? [I] [GTL]
```

**Figure 3-9. Sample MET/CAL Program (cont.)**

**DC Volts Calibration (AUX Output)**

To calibrate the auxiliary dc voltage function, use the same procedure used for the normal dc voltage output, but connect to the AUX HI and LO terminals on the UUT. Table 3-12 is a list of the calibration steps for AUX dc volts.

**Table 3-12. AUX DC Volts Calibration Steps**

Step	5522A Output (AUX)
1	300.000 mV
2	3.00000 V
3	7.00000 V

**AC Volts Calibration (AUX Output)**

To calibrate the auxiliary ac voltage function, use the same procedure used for the normal ac voltage output, but connect to the AUX HI and LO terminals on the UUT. Table 3-13 is a list of the calibration steps for AUX dc volts.

**Table 3-13. AUX Output AC Volts Calibration Steps**

Step	5522A Output (AUX)	
	Amplitude	Frequency
1	300.000 mV	100 Hz
2	300.000 mV	5 kHz
3	3.00000 V	100 Hz
4	3.00000 V	5 kHz
5	5.0000 V	100 Hz
6	5.0000 V	5 kHz
7	3.0 V	9.99 Hz

### Resistance Calibration

Table 3-14 is a list of equipment necessary to calibrate the resistance function. (The equipment is also shown in the consolidated table, Table 3-1.)

**Table 3-14. Test Equipment Necessary for Resistance Calibration**

Qty	Manufacturer	Model	Equipment
1	Fluke	5500A/LEADS	Test lead set
1	Fluke	8508A	Reference Multimeter

To calibrate the resistance function:

1. On the Fluke 8508A put a 4-wire short (Fluke PN 2540973) across the HI and LO input and sense terminals.
2. Push Ohms, then INPUT, and then ZERO FUNC. Allow the zero function to finish.
3. Make sure that the UUT (Unit Under Test) is in Standby.
4. Follow the instructions on the Control Display to connect the 8508A to the UUT for 4 wire ohms measurement as shown in Figure 3-10.
5. Push the **GO ON** softkey and let the internal calibration steps complete.
6. Measure and type the values into the UUT for calibration steps 1 through 8 in Table 3-15 as instructed.
7. Connect the UUT to the 8508A in a 2-wire ohms configuration as shown in Figure 3-11.
8. On the 8508A, set the function to OHMS. In the Ohms Config menu, turn on **LoI** and turn off **Fast** and **4wΩ**. Set the applicable resistance range for each step in Table 3-15.
9. Measure and type the values into the UUT for calibration steps 9 through 16 in Table 3-15 as instructed.
10. Make sure that the UUT is in standby and disconnect the equipment.

**Table 3-15. Resistance Calibration Steps**

Step	5522A Output (4-Wire Ohms, NORMAL and AUX)
1	1.0000 Ω
2	11.0000 Ω
3	110.0000 Ω
4	0.350000 kΩ
5	1.100000 kΩ
6	3.50000 kΩ
7	11.00000 kΩ
8	35.0000 kΩ
<b>2-Wire Ohms, NORMAL</b>	
9	110.0000 kΩ
10	0.350000 MΩ

Table 3-15. Resistance Calibration Steps (cont.)

Step	5522A Output (2-Wire Ohms, NORMAL)
11	1.100000 MΩ
12	3.50000 MΩ
13	11.00000 MΩ
14	35.0000 MΩ
15	110.000 MΩ
16	400.00 MΩ

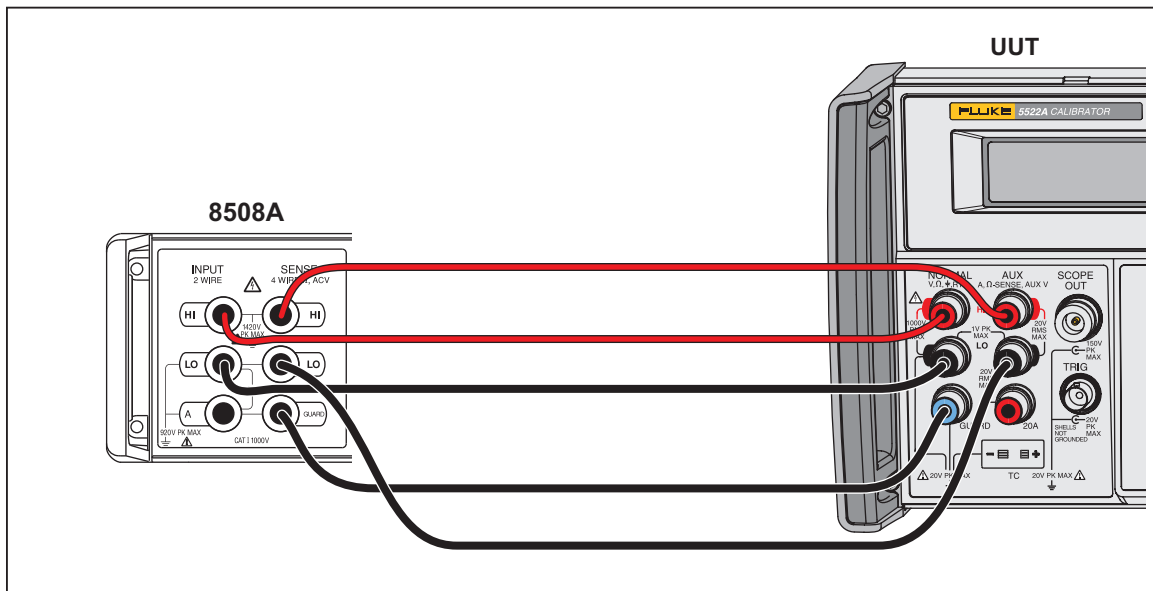

Figure 3-10. 4-Wire Resistance Connection

gjh119.eps

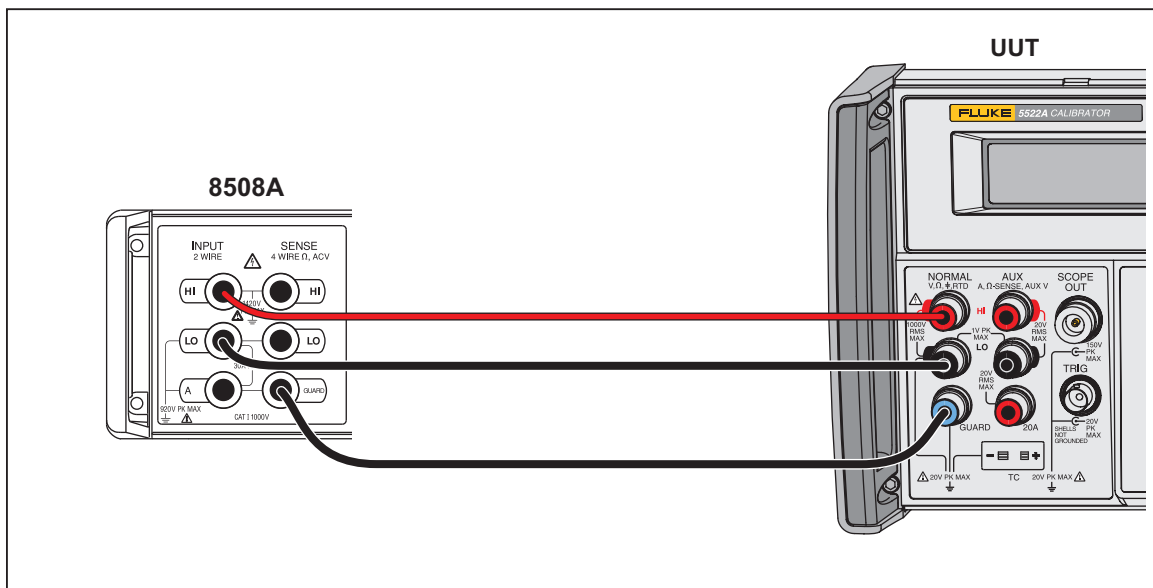

Figure 3-11. 2-Wire Resistance Connection

gjh121.eps

### Capacitance Calibration

Table 3-16 is a list of equipment necessary to calibrate the capacitance function. (The equipment is also shown Table 3-1.)

**Table 3-16. Test Equipment Necessary for Capacitance Calibration**

Qty	Manufacturer	Model	Equipment
1	Fluke	PM 9540/BAN	Cable Set
1	Fluke	PM 6304C	LCR Meter

To calibrate the capacitance function:

1. Connect the UUT to the LCR meter with the Fluke PM 9540/BAN cables as shown in Figure 3-12. These special cables remove the necessity for a four-wire connection.

*Note*

*Make sure there are no other connections to the Calibrator, especially the SCOPE BNC. More ground connections to the Calibrator can cause erroneous capacitance outputs.*

2. Set the frequency on the LCR meter as shown in Table 3-17.
3. Measure and type the values into the UUT for the calibration steps in Table 3-17 as instructed. The right column in the table shows the best stimulus frequency for each calibration point.
4. Make sure that the UUT is in Standby and disconnect the LCR meter.

**Table 3-17. Capacitance Calibration Steps**

Step	5522A Output (NORMAL)	
	Calibrator Output	Best Stimulus Frequency
1	200 pF	1 kHz
2	0.5000 nF	1 kHz
3	1.1000 nF	1 kHz
4	3.5000 nF	1 kHz
5	11.0000 nF	1 kHz
6	35.000 nF	1 kHz
7	110.000 nF	1 kHz
8	0.35000 $\mu$ F	100 Hz
9	1.10000 $\mu$ F	100 Hz
10	3.3000 $\mu$ F	100 Hz
11	11.0000 $\mu$ F	100 Hz
12	33.000 $\mu$ F	100 Hz

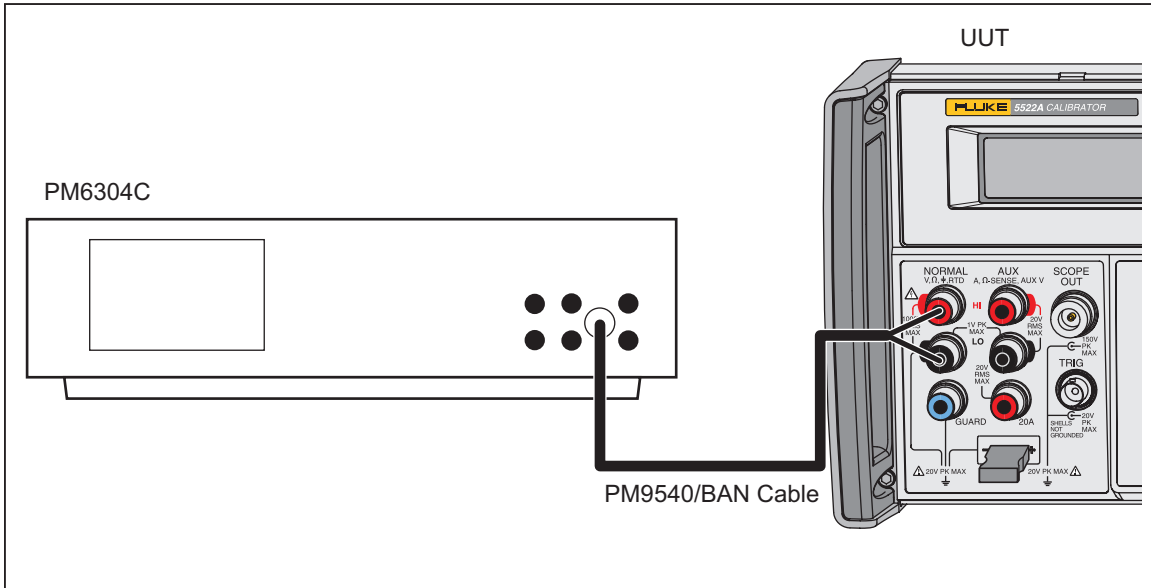

Figure 3-12. Capacitance Calibration Connection

gjh123.eps

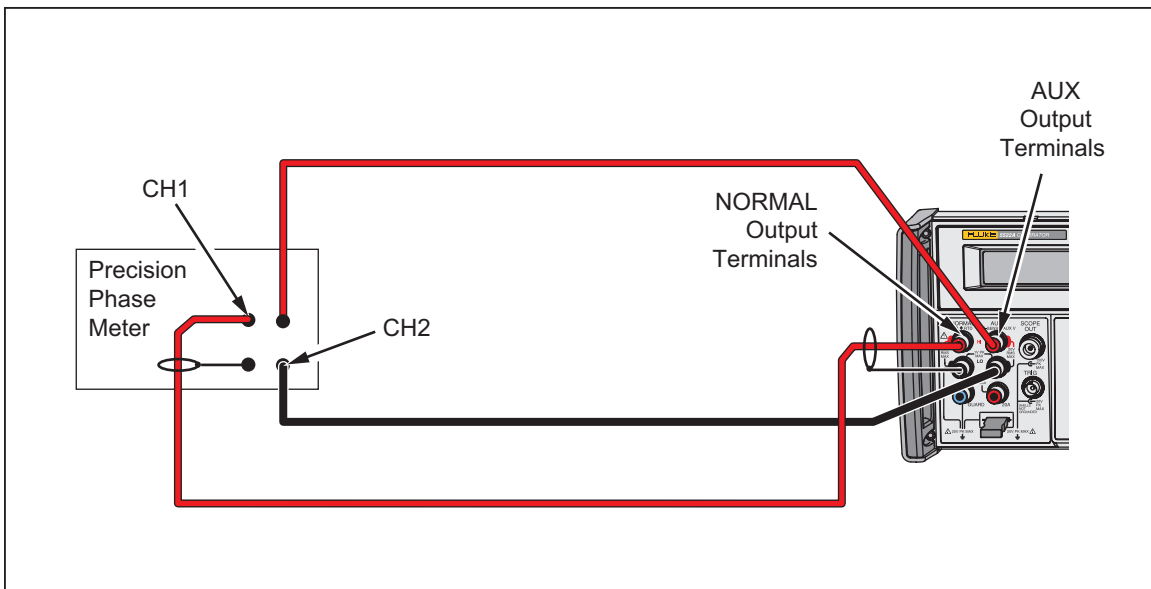

Figure 3-13. Normal Volts and AUX Volts Phase Verification Connection

gjh102.eps

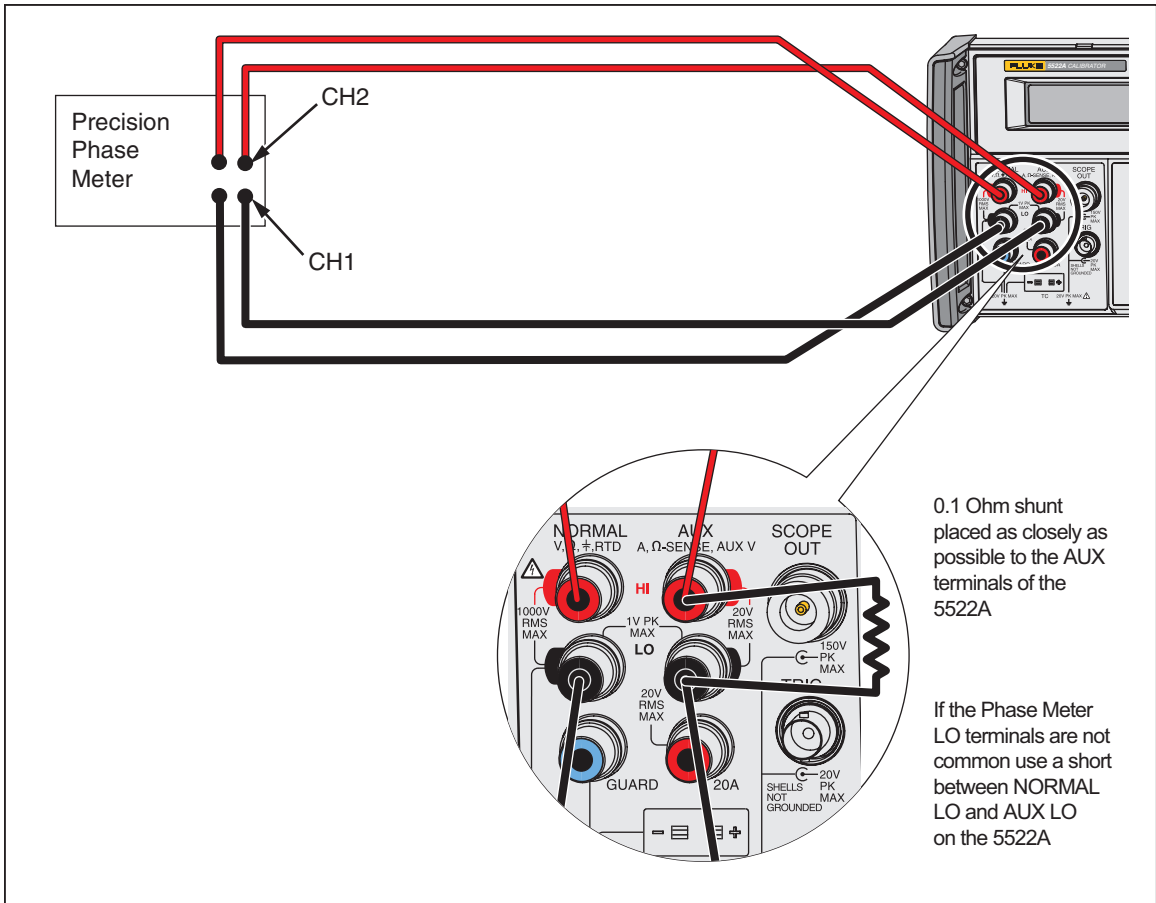

Figure 3-14. Volts and Current Phase Verification Connection

gjh133.eps

### Calibration Remote Commands

Calibration of the calibrator with remote commands is simple. To access the standard calibration steps, send the command:

CAL\_START MAIN

To jump to specified calibration steps, you can append a modifier to this command. Table 3-18 is a list of calibration entry points.

Table 3-18. Calibration Entry Points in Remote

Entry Points for CAL_START MAIN	Modifier
AC Volts	AV
Thermocouple Measuring	TEMPX
DC Current	ICAL
AC Current	AI
AUX DC Volts	V2
AUX AC Volts	AVS
Resistance	R
Capacitance	C
AC Volts	AV

To go directly to ac volts calibration, send:

CAL\_START MAIN,AV

To go directly to resistance calibration, send:

CAL\_START MAIN,R

These calibration commands can be used through the IEEE-488 or serial interface. To use the serial interface without a calibration program:

1. Connect the applicable COM port from a PC to the Serial 1 connector of the Calibrator, with a Fluke PM8914 cable.
2. In Microsoft Windows, open the Terminal program. Set the communications parameters to the values of the Calibrator.
3. Push . Type the calibration command, for example, CAL\_START MAIN.

What follows is a list of remote calibration commands for the Calibrator. The common commands in this list do not show the \* character that must be the first character of the command. These remote commands duplicate what can be initiated through the front panel of the Calibrator when it is set to local mode.

**IEEE-488 (GPIB) and RS-232 Applicability** Each command title shown in this section shares the same remote interface applicability, IEEE-488 (general purpose interface bus, or GPIB) and RS-232 remote operations, and command group: Sequential, Overlapped, and Coupled.

IEEE-488     RS-232     Sequential     Overlapped     Coupled

**Sequential Commands** Commands executed immediately as they are found in the data stream are called sequential commands. A command that is not overlapped or coupled is sequential.

**Overlapped Commands** Commands that require additional time to execute are called overlapped commands because they can overlap the next command before execution is done.

**Coupled Commands** Some commands are coupled commands because they “couple” in a compound command sequence. You must be careful to make sure that one command does not disable the second command and thereby cause a fault.

---

### CAL\_ABORT

Description:    Instructs the Calibrator to abort the calibration procedure after the present step

Example:        CAL\_ABORT

---

### **CAL\_BACKUP**

Description: Skip to the subsequent entry point in calibration procedure.

---

### **CAL\_DATE?**

Description: Sends a calibration date related to the stored calibration constants.  
The date is sent with the same format as the CLOCK command.

Parameter: Which date: MAIN, ZERO, OHMSZERO, SCOPE

Response: The date

---

### **CAL\_DAYS?**

Description: Sends the number of days and hours since the last calibration constants were stored.

Parameter: Which date: MAIN, ZERO, OHMSZERO, SCOPE

Response: 1. (Integer) Days  
2. (Integer) Hours

---

### **CAL\_FACT**

Description: Set the procedure "fault action" flag. Procedures refer to calibration and diagnostic procedures. This command is more useful for diagnostics than calibration.

Parameter: (Character) CONT to continue on faults or ABORT to abort on faults

Example: CAL\_FACT ABORT (this is the default)

---

### **CAL\_FACT?**

Description: Get the procedure "fault action" flag.

Response: (Character) CONT or ABORT

Example: ABORT

---

### **CAL\_FAULT?**

Description: Get information about calibration error (if one occurred).

Response: 1. error number (use EXPLAIN? command to interpret)  
2. Name of step where error occurred

---

### **CAL\_INFO?**

Description: Sends message or instructions related to the present step.

Response: (String) the message string

---

**CAL\_NEXT**

Description: Continue a calibration procedure if it is stopped for a CAL\_NEXT command.

Parameter: (Optional) reference value (used if it's waiting for a reference) If the reference value has no unit, the unit is assumed to be that returned by the CAL\_REF? command

Example: CAL\_NEXT  
CAL\_NEXT 2.999987

---

**CAL\_REF?**

Description: Sends nominal value possible for reference entry.

Response: 1. The nominal value  
2. The accepted or implied unit  
3. Example: 3.000000e+00,V

---

**CAL\_SKIP**

Description: Skip to the subsequent entry point in calibration procedure.

---

**CAL\_SECT**

Description: Skip to the subsequent section of calibration procedure.

---

**CAL\_START**

Description: Start a calibration procedure.

Parameter: 1. Procedure name:  
     MAIN is the procedure for the 5520A minus a scope cal option  
     ZERO is the internal procedure to correct zero offsets  
     OHMSZERO is the internal procedure to touch up resistance offsets  
     SCOPE is the procedure for the 5520A-SC300 scope cal option  
     SC600 is the procedure for the 5520A-SC600 scope cal option  
     SC1100 is the procedure for the 5522A-SC1100 cal option  
     DIAG is the diagnostic pseudo-cal procedure  
     NOT aborts a procedure after the step underway

2. (Optional) name of the step at which to start.  
 If this parameter is not supplied, calibration starts at the start.

Example: CAL\_START MAIN  
CAL\_START MAIN,DVG3\_3

---

### **CAL\_STATE?**

Description: Sends state of calibration.

Response: RUN - In a calibration step  
REF - Stopped for a CAL\_NEXT with reference (measurement) value  
INS - Instruction available, stopped for a CAL\_NEXT  
NOT - Not in a calibration procedure (or at end of one)

---

### **CAL\_STEP?**

Description: Sends name of step currently running.

Response: (Char) the step name

Example: IDAC\_RATIO (running IDAC ratio calibration)  
NOT (not running a calibration procedure now)

---

### **CAL\_STORE**

Description: Store new calibration constants (CAL switch must be ENABLED).

---

### **CAL\_STORE?**

Description: Sends if a cal store is necessary or not.

Response: 1 is yes, 0 if no

---

### **CAL\_SW?**

Description: Sends how the calibration switch is set.

Response: (Integer) 1 for enable, 0 for normal

Example: 1

---

### **EOFSTR**

Description: Sets the End-Of-File character string used for calibration reports.

The maximum length is two characters. The EOF character is kept in nonvolatile memory.

Parameter: The EOF string (two characters maximum)

---

### **EOFSTR?**

Description: Sends the End-Of-File character string used for calibration reports.

Parameter: None

Response: (String) The End-Of-File character string

### **PR\_RPT**

Description: Prints a self-calibration report out of one of the serial ports

- Parameter:
1. Type of report to print: STORED, ACTIVE, or CONSTS
  2. Format of report: PRINT (designed to be read)  
 SPREAD (designed to be loaded into a spreadsheet)
  3. Calibration interval to be used for instrument specifications in the report: I90D (90 day specifications) or I1Y (1 year specifications)
  4. Serial port out which to print report: HOST or UUT

Example: PR\_RPT STORED,PRINT,I90D,HOST

### **RPT?**

Description: Sends a self-calibration report.

- Parameter:
1. Type of report to send: STORED, ACTIVE, or CONSTS
  2. Format of report: PRINT (designed to be read)  
 SPREAD (designed to be loaded into a spreadsheet)
  3. Calibration interval to be used for instrument specifications in the report:  
 I90D (90 day specifications) or I1Y (1 year specifications)

Example: RPT? STORED,PRINT,I90D

### **RPT\_PLEN**

Description: Sets the page length used for calibration reports. This parameter is stored in nonvolatile memory.

Parameter: Page length

### **RPT\_PLEN?**

Description: Sends the page length used for calibration reports.

Parameter: None

Response: (Integer) Page length

### **RPT\_STR**

Description: Sets the user report string used for calibration reports. The string is stored in nonvolatile memory. The CALIBRATION switch must be set to ENABLE.

Parameter: String of a maximum of 40 characters

---

### RPT\_STR?

Description: Sends the user report string used for calibration reports.

Parameter: None

Response: (String) A maximum of 40 characters

---

### STOP\_PR

Description: Stops a calibration report print job if one was queued to print.

Parameter: None

---

### UNCERT?

Description: Sends specified uncertainties for the present output. If there is no specification for an output, the uncertainty sent is zero.

Parameter: 1. (Optional) The preferred unit in which to express the primary output uncertainty (default is PCT).  
2. (Optional) The preferred unit in which to express the secondary output uncertainty (default is same as primary unit).

Response: 1. (Float) 90 day specified uncertainty of primary output.  
2. (Float) 1 year specified uncertainty of primary output.  
3. (Character) unit of primary output uncertainty.  
4. (Float) 90 day specified uncertainty of secondary output.  
5. (Float) 1 year specified uncertainty of secondary output.  
6. (Character) unit of secondary output uncertainty.

Example: With a power output of 1V, 1A, 1kHz:  
UNCERT?  
Sends 2.00E-02,2.10E-02,PCT,4.60E-02,6.00E-02,PCT

## **How to Make a Calibration Report**

Three different calibration reports are available from the Calibrator, each one formatted to print, or in comma-separated variable format for importation into a spreadsheet. Use the **REPORT SETUP** softkey below **UTILITY FUNCTS / CAL** to select lines per page, calibration interval, type of report, format, and which serial port to use. The specification shown in these reports is contingent on the interval set in the **REPORT SETUP** menu.

The three report types are:

- “**stored**,” lists output shifts as a result of the most recent stored calibration constants.
- “**active**,” lists output shifts as a result of a calibration just performed but whose calibration constants are not yet stored.
- “**consts**,” which is a listing of the active set of raw calibration constant values.

## Performance Verification Tests

The tests that follow are used to verify the performance of the Calibrator. If an out-of-tolerance condition is found, the instrument can be re-calibrated with the front panel or the remote interface.

Use the same test equipment and connection methods as used in the manual calibration procedures in this Chapter.

Zero the Calibrator before you do a test. See the “Zeroing the Calibrator” section.

### How to Zero the Calibrator

When you zero the Calibrator, it recalibrates internal circuitry. This includes the dc offsets in all ranges of operation. Zero the Calibrator on a 7 day interval, or when the Calibrator ambient temperature changes by more than 5 °C so the Calibrator operates to the specifications in Chapter 1. There are two Calibrator zero functions: total instrument zero (ZERO) and ohms-only zero (OHMS ZERO). Before you do the verification tests, do the total instrument zero.

To zero the calibrator:

*Note*

*The Calibrator rear-panel CALIBRATION switch does not have to be set to ENABLE for this procedure.*

Turn on the Calibrator and let it warm-up for a minimum of 30 minutes.

1. Push **RESET**.
2. Install a low-ohm copper short circuit across the **20 A** and **AUX LO** terminals.
3. Push **SETUP**. This opens the setup menu.
4. Push the **CAL** softkey. This opens the calibration information menu.
5. Push the **CAL** softkey.
6. Push the **ZERO** softkey to totally zero the Calibrator. When the zero procedure is done (20 minutes), push **RESET** to reset the calibrator.

### DC Volts Verification (NORMAL Output)

Make sure the Calibrator outputs the voltage between the high and low limits shown in Table 3-19. Use the same procedures and equipment that are in the manual calibration section.

**Table 3-19. Verification Tests for DC Voltage (NORMAL Output)**

Range	Output	Low Limit	High Limit
329.9999 mV	0.0000 mV	-0.0010 mV	0.0010 mV
329.9999 mV	329.0000 mV	328.9941 mV	329.0059 mV
329.9999 mV	-329.0000 mV	-329.0059 mV	-328.9941 mV
3.299999 V	0.000000 V	-0.000002 V	0.000002 V
3.299999 V	1.000000 V	0.999989 V	1.000011 V
3.299999 V	-1.000000 V	-1.000011 V	-0.999989 V
3.299999 V	3.290000 V	3.289968 V	3.290032 V
3.299999 V	-3.290000 V	-3.290032 V	-3.289968 V

**Table 3-19. Verification Tests for DC Voltage (NORMAL Output) (cont.)**

Range	Output	Low Limit	High Limit
32.99999 V	0.00000 V	-0.00002 V	0.00002 V
32.99999 V	10.00000 V	9.99988 V	10.00012 V
32.99999 V	-10.00000 V	-10.00012 V	-9.99988 V
32.99999 V	32.90000 V	32.89965 V	32.90035 V
32.99999 V	-32.90000 V	-32.90035V	-32.89965 V
329.9999 V	50.0000 V	49.9991 V	50.0009 V
329.9999 V	329.0000 V	328.9949 V	329.0051 V
329.9999 V	-50.0000 V	-50.0009 V	-49.9991 V
329.9999 V	-329.0000 V	-329.0051 V	-328.9949 V
1000.000 V	334.000 V	333.993 V	334.007 V
1000.000 V	900.000 V	899.985 V	900.015 V
1000.000 V	1020.000 V	1019.983 V	1020.017 V
1000.000 V	-334.000 V	-334.007 V	-333.993 V
1000.000 V	-900.000 V	-900.015 V	-899.985 V
1000.000 V	-1020.000 V	-1020.017 V	-1019.983 V

**DC Volts Verification (AUX Output)**

Make sure the Calibrator outputs the voltage between the high and low limits shown in Table 3-20. Use the same procedures and equipment that are in the manual calibration section.

**Table 3-20. Verification Tests for DC Voltage (AUX Output)**

Range	Output	Low Limit	High Limit
329.999 mV	0.000 mV	-0.350 mV	0.350 mV
329.999 mV	329.000 mV	328.551 mV	329.449 mV
329.999 mV	-329.000 mV	-329.449 mV	-328.551 mV
3.29999 V	0.33000 V	0.32955 V	0.33045 V
3.29999 V	3.29000 V	3.28866 V	3.29134 V
3.29999 V	-3.29000 V	-3.29134 V	-3.28866 V
7.0000 V	7.0000 V	6.9975 V	7.0025 V
7.0000 V	-7.0000 V	-7.0025 V	-6.9975 V

**DC Current Verification**

Make sure the Calibrator outputs the current between the high and low limits shown in Table 3-22. Use the same procedures and equipment that are in the manual calibration section. Use the shunt values in Table 3-21.

**Table 3-21. Shunt Values for DC Current Calibration and Verification**

Range of Verification Points	Shunt
± (0 to 329.000 µA)	Fluke 742A-1k 1k Ω Resistance Standard
± (1.9 mA to 3.29000 mA)	Fluke 742A-100 100 Ω Resistance Standard
± (19.0000 mA to 32.9000 mA)	Fluke 742A-10 10 Ω Resistance Standard
± (190.000 mA to 329.000 mA)	Fluke 742A-1 1 Ω Resistance Standard
± (1.09000 A)	Guidline 9230 0.1 Ω Shunt
± (2.00000 A to 20.0000 A)	Guidline 9230 0.01 Ω Shunt

**Table 3-22. Verification Tests for DC Current (AUX Output)**

Range	Output	Low Limit	High Limit
329.999 µA	0.000 µA	-0.020 µA	0.020 µA
329.999 µA	190.000 µA	189.957 µA	190.043 µA
329.999 µA	-190.000 µA	-190.043 µA	-189.957 µA
329.999 µA	329.000 µA	328.941 µA	329.059 µA
329.999 µA	-329.000 µA	-329.059 µA	-328.941 µA
3.29999 mA	0.00000 mA	-0.00005 mA	0.00005 mA
3.29999 mA	1.90000 mA	1.89980 mA	1.90020 mA
3.29999 mA	-1.90000 mA	-1.90020 mA	-1.89980 mA
3.29999 mA	3.29000 mA	3.28969 mA	3.29031 mA
3.29999 mA	-3.29000 mA	-3.29031 mA	-3.28969 mA
32.9999 mA	0.0000 mA	-0.00025 mA	0.00025 mA
32.9999 mA	19.0000 mA	18.9982 mA	19.0018 mA
32.9999 mA	-19.0000 mA	-19.0018 mA	-18.9982 mA
32.9999 mA	32.9000 mA	32.8971 mA	32.9029 mA
32.9999 mA	-32.9000 mA	-32.9029 mA	-32.8971 mA
329.999 mA	0.000 mA	-0.0025 mA	0.0025 mA
329.999 mA	190.000 mA	189.982 mA	190.018 mA
329.999 mA	-190.000 mA	-190.018 mA	-189.982 mA
329.999 mA	329.000 mA	328.971 mA	329.029 mA
329.999 mA	-329.000 mA	-329.029 mA	-328.971 mA
2.99999 A	0.00000 A	-0.00004 A	0.00004 A

Table 3-22. Verification Tests for DC Current (AUX Output) (cont.)

Range	Output	Low Limit	High Limit
2.99999 A	1.09000 A	1.08979 A	1.09021 A
2.99999 A	-1.09000 A	-1.09021 A	-1.08979 A
2.99999 A	2.99000 A	2.98906 A	2.99094 A
2.99999 A	-2.99000 A	-2.99094 A	-2.98906 A
20.5000 A	0.0000 A	-0.0005 A	0.0005 A
20.5000 A	10.9000 A	10.8954 A	10.9046 A
20.5000 A	-10.9000 A	-10.9046 A	-10.8954 A
20.5000 A	20.0000 A	19.9833 A	20.0167 A
20.5000 A	-20.0000 A	-20.0167 A	-19.9833 A

**Resistance Verification**

Make sure the Calibrator outputs the resistance between the high and low limits shown in Table 3-23. Use the same procedures and equipment that are in the manual calibration section. Use 4-wire measurements for resistances less than 110 k $\Omega$  and 2-wire measurements for higher values.

Table 3-23. Verification Tests for Resistance

Range	Output	Low Limit	High Limit
10.9999 $\Omega$	0.0000 $\Omega$	-0.0010 $\Omega$	0.0010 $\Omega$
10.9999 $\Omega$	2.0000 $\Omega$	1.9989 $\Omega$	2.0011 $\Omega$
10.9999 $\Omega$	10.9000 $\Omega$	10.8986 $\Omega$	10.9014 $\Omega$
32.9999 $\Omega$	11.9000 $\Omega$	11.8982 $\Omega$	11.9018 $\Omega$
32.9999 $\Omega$	19.0000 $\Omega$	18.9980 $\Omega$	19.0020 $\Omega$
32.9999 $\Omega$	30.0000 $\Omega$	29.9978 $\Omega$	30.0022 $\Omega$
109.9999 $\Omega$	33.0000 $\Omega$	32.9979 $\Omega$	33.0021 $\Omega$
109.9999 $\Omega$	109.0000 $\Omega$	108.9962 $\Omega$	109.0038 $\Omega$
329.9999 $\Omega$	119.0000 $\Omega$	118.9954 $\Omega$	119.0046 $\Omega$
329.9999 $\Omega$	190.0000 $\Omega$	189.9938 $\Omega$	190.0062 $\Omega$
329.9999 $\Omega$	300.0000 $\Omega$	299.9914 $\Omega$	300.0086 $\Omega$
1.099999 k $\Omega$	0.330000 k $\Omega$	0.329991 k $\Omega$	0.330009 k $\Omega$
1.099999 k $\Omega$	1.090000 k $\Omega$	1.089974 k $\Omega$	1.090026 k $\Omega$
3.299999 k $\Omega$	1.190000 k $\Omega$	1.189954 k $\Omega$	1.190046 k $\Omega$
3.299999 k $\Omega$	1.900000 k $\Omega$	1.899938 k $\Omega$	1.900062 k $\Omega$
3.299999 k $\Omega$	3.000000 k $\Omega$	2.999914 k $\Omega$	3.000086 k $\Omega$
10.99999 k $\Omega$	3.30000 k $\Omega$	3.29991 k $\Omega$	3.30009 k $\Omega$
10.99999 k $\Omega$	10.90000 k $\Omega$	10.89974 k $\Omega$	10.90026 k $\Omega$

**Table 3-23. Verification Tests for Resistance (cont.)**

Range	Output	Low Limit	High Limit
32.99999 kΩ	11.90000 kΩ	11.89954 kΩ	11.90046 kΩ
32.99999 kΩ	19.00000 kΩ	18.99938 kΩ	19.00062 kΩ
32.99999 kΩ	30.00000 kΩ	29.99914 kΩ	30.00086 kΩ
109.9999 kΩ	33.0000 kΩ	32.9991 kΩ	33.0009 kΩ
109.9999 kΩ	109.0000 kΩ	108.9974 kΩ	109.0026 kΩ
329.9999 kΩ	119.0000 kΩ	118.9950 kΩ	119.0050 kΩ
329.9999 kΩ	190.0000 kΩ	189.9933 kΩ	190.0067 kΩ
329.9999 kΩ	300.0000 kΩ	299.9905 kΩ	300.0095 kΩ
1.099999 MΩ	0.330000 MΩ	0.329990 MΩ	0.330010 MΩ
1.099999 MΩ	1.090000 MΩ	1.089971 MΩ	1.090029 MΩ
3.299999 MΩ	1.190000 MΩ	1.189922 MΩ	1.190078 MΩ
3.299999 MΩ	1.900000 MΩ	1.899894 MΩ	1.900106 MΩ
3.299999 MΩ	3.000000 MΩ	2.999850 MΩ	3.000150 MΩ
10.99999 MΩ	3.30000 MΩ	3.29959 MΩ	3.30041 MΩ
10.99999 MΩ	10.90000 MΩ	10.89875 MΩ	10.90125 MΩ
32.99999 MΩ	11.90000 MΩ	11.89512 MΩ	11.90488 MΩ
32.99999 MΩ	19.00000 MΩ	18.99370 MΩ	19.00630 MΩ
32.99999 MΩ	30.00000 MΩ	29.99150 MΩ	30.00850 MΩ
109.9999 MΩ	33.0000 MΩ	32.9838 MΩ	33.0162 MΩ
109.9999 MΩ	109.0000 MΩ	108.9534 MΩ	109.0466 MΩ
329.9999 MΩ	119.0000 MΩ	118.6025 MΩ	119.3975 MΩ
329.9999 MΩ	290.0000 MΩ	289.1750 MΩ	290.8250 MΩ
1100.000 MΩ	400.000 MΩ	394.700 MΩ	405.300 MΩ
1100.000 MΩ	640.000 MΩ	631.820 MΩ	648.180 MΩ
1100.000 MΩ	1090.000 MΩ	1076.420 MΩ	1103.580 MΩ

**AC Voltage Verification (NORMAL Output)**

Make sure the Calibrator outputs the voltage between the high and low limits shown in Table 3-24. Use the same procedures and equipment that are in the manual calibration section.

**Table 3-24. Verification Tests for AC Voltage (NORMAL Output)**

Range	Output	Frequency	Low Limit	High Limit
32.999 mV	3.000 mV	45 Hz	2.994 mV	3.006 mV
32.999 mV	3.000 mV	10 kHz	2.994 mV	3.006 mV

Table 3-24. Verification Tests for AC Voltage (NORMAL Output) (cont.)

Range	Output	Frequency	Low Limit	High Limit
32.999 mV	30.000 mV	9.5 Hz	28.335 mV	31.665 mV
32.999 mV	30.000 mV	10 Hz	29.976 mV	30.024 mV
32.999 mV	30.000 mV	45 Hz	29.990 mV	30.010 mV
32.999 mV	30.000 mV	1 kHz	29.990 mV	30.010 mV
32.999 mV	30.000 mV	10 kHz	29.990 mV	30.010 mV
32.999 mV	30.000 mV	20 kHz	29.989 mV	30.011 mV
32.999 mV	30.000 mV	50 kHz	29.970 mV	30.030 mV
32.999 mV	30.000 mV	100 kHz	29.898 mV	30.102 mV
32.999 mV	30.000 mV	450 kHz	29.770 mV	30.230 mV
329.999 mV	33.000 mV	45 Hz	32.987 mV	33.013 mV
329.999 mV	33.000 mV	10 kHz	32.987 mV	33.013 mV
329.999 mV	300.000 mV	9.5 Hz	283.350 mV	316.650 mV
329.999 mV	300.000 mV	10 Hz	299.917 mV	300.083 mV
329.999 mV	300.000 mV	45 Hz	299.950 mV	300.050 mV
329.999 mV	300.000 mV	1 kHz	299.950 mV	300.050 mV
329.999 mV	300.000 mV	10 kHz	299.950 mV	300.050 mV
329.999 mV	300.000 mV	20 kHz	299.947 mV	300.053 mV
329.999 mV	300.000 mV	50 kHz	299.902 mV	300.098 mV
329.999 mV	300.000 mV	100 kHz	299.788 mV	300.212 mV
329.999 mV	300.000 mV	500 kHz	299.450 mV	300.550 mV
3.29999 V	0.33000 V	45 Hz	0.32989 V	0.33011 V
3.29999 V	0.33000 V	10 kHz	0.32989 V	0.33011 V
3.29999 V	3.00000 V	9.5 Hz	2.83350 V	3.16650 V
3.29999 V	3.00000 V	10 Hz	2.99920 V	3.00080 V
3.29999 V	3.00000 V	45 Hz	2.99952 V	3.00048 V
3.29999 V	3.00000 V	1 kHz	2.99952 V	3.00048 V
3.29999 V	3.00000 V	10 kHz	2.99952 V	3.00048 V
3.29999 V	3.00000 V	20 kHz	2.99946 V	3.00054 V
3.29999 V	3.00000 V	50 kHz	2.99920 V	3.00080 V
3.29999 V	3.00000 V	100 kHz	2.99822 V	3.00178 V
3.29999 V	3.00000 V	450 kHz	2.99340 V	3.00660 V
3.29999 V	3.29000 V	2 MHz	0.07500 V <sup>[1]</sup>	
32.9999 V	3.3000 V	45 Hz	3.2990 V	3.3010 V

**Table 3-24. Verification Tests for AC Voltage (NORMAL Output) (cont.)**

Range	Output	Frequency	Low Limit	High Limit
32.9999 V	3.3000 V	10 kHz	3.2990 V	3.3010 V
32.9999 V	30.0000 V	9.5 Hz	28.3350 V	31.6650 V
32.9999 V	30.0000 V	10 Hz	29.9919 V	30.0081 V
32.9999 V	30.0000 V	45 Hz	29.9957 V	30.0043 V
32.9999 V	30.0000 V	1 kHz	29.9957 V	30.0043 V
32.9999 V	30.0000 V	10 kHz	29.9957 V	30.0043 V
32.9999 V	30.0000 V	20 kHz	29.9928 V	30.0072 V
32.9999 V	30.0000 V	50 kHz	29.9904 V	30.0096 V
32.9999 V	30.0000 V	90 kHz	29.9759 V	30.0241 V
329.999 V	33.000 V	45 Hz	32.993 V	33.007 V
329.999 V	33.000 V	10 kHz	32.989 V	33.011 V
329.999 V	300.000 V	45 Hz	299.953 V	300.047 V
329.999 V	300.000 V	1 kHz	299.953 V	300.047 V
329.999 V	300.000 V	10 kHz	299.946 V	300.054 V
329.999 V	300.000 V	18 kHz	299.928 V	300.072 V
329.999 V	300.000 V	50 kHz	299.922 V	300.078 V
329.999 V	200.000 V	100 kHz	199.630 V	200.370 V
1020.00 V	330.00 V	45 Hz	329.91 V	330.09 V
1020.00 V	330.00 V	10 kHz	329.91 V	330.09 V
1020.00 V	1000.00 V	45 Hz	999.74 V	1000.26 V
1020.00 V	1000.00 V	1 kHz	999.79 V	1000.21 V
1020.00 V	1000.00 V	5 kHz	999.79 V	1000.21 V
1020.00 V	1000.00 V	8 kHz	999.74 V	1000.26 V
1020.00 V	1020.00 V	1 kHz	1019.79 V	1020.21 V
1020.00 V	1020.00 V	8 kHz	1019.74 V	1020.26 V

[1] Typical specification is -24 dB at 2 MHz

**AC Voltage Verification (AUX Output)**

Make sure the Calibrator outputs the voltage between the high and low limits shown in Table 3-25. Use the same procedures and equipment that are in the manual calibration section.

**Table 3-25. Verification Tests for AC Voltage (AUX Output)**

Range	Output, AUX <sup>[1]</sup>	Frequency	Low Limit	High Limit
329.999 mV	10.000 mV	45 Hz	9.622 mV	10.378 mV
329.999 mV	10.000 mV	1 kHz	9.622 mV	10.378 mV

Table 3-25. Verification Tests for AC Voltage (AUX Output) (cont.)

Range	Output, AUX <sup>[1]</sup>	Frequency	Low Limit	High Limit
329.999 mV	10.000 mV	5 kHz	9.535 mV	10.465 mV
329.999 mV	10.000 mV	10 kHz	9.520 mV	10.480 mV
329.999 mV	10.000 mV	30 kHz	8.700 mV	11.300 mV
329.999 mV	300.000 mV	9.5 Hz	283.350 mV	316.650 mV
329.999 mV	300.000 mV	10 Hz	299.180 mV	300.820 mV
329.999 mV	300.000 mV	45 Hz	299.390 mV	300.610 mV
329.999 mV	300.000 mV	1 kHz	299.390 mV	300.610 mV
329.999 mV	300.000 mV	5 kHz	299.100 mV	300.900 mV
329.999 mV	300.000 mV	10 kHz	298.650 mV	301.350 mV
329.999 mV	300.000 mV	30 kHz	287.100 mV	312.900 mV
3.29999 V	3.00000 V	9.5 Hz	2.825 V	3.175 V
3.29999 V	3.00000 V	10 Hz	2.99505 V	3.00495 V
3.29999 V	3.00000 V	45 Hz	2.99745 V	3.00255 V
3.29999 V	3.00000 V	1 kHz	2.99745 V	3.00255 V
3.29999 V	3.00000 V	5 kHz	2.99410 V	3.00590 V
3.29999 V	3.00000 V	10 kHz	2.98960 V	3.01040 V
3.29999 V	3.00000 V	30 kHz	2.87720 V	3.12280 V
5.00000 V	5.00000 V	9.5 Hz	4.72500 V	5.27500 V
5.00000 V	5.00000 V	10 Hz	4.99205 V	5.00795 V
5.00000 V	5.00000 V	45 Hz	4.99605 V	5.00395 V
5.00000 V	5.00000 V	1 kHz	4.99605 V	5.00395 V
5.00000 V	5.00000 V	5 kHz	4.99110 V	5.00890 V
5.00000 V	5.00000 V	10 kHz	4.98360 V	5.01640 V

[1] Set the Normal output to 300 mV.

### AC Current Verification

Make sure the Calibrator outputs the current between the high and low limits shown in Table 3-27. Use the UUT dc current function that was verified before as the dc current source to make ac/dc current transfers with the 5790A. Use the shunt values in Table 3-26. See Figure 3-15 for the correct equipment connections. For ranges 19 mA to 2 A, refer to Figure 3-7. For more than 2 A, refer to Figure 3-8 for the setup connections.

Table 3-26. Shunt Values for AC Current Verification

Range of Verification Points (rms values)	Shunt
0 to 329.000 $\mu$ A	1 k $\Omega$ metal film resistor in a shielded box
1.9 mA to 3.29990 mA	200 $\Omega$ metal film resistor in a shielded box

**Table 3-26. Shunt Values for AC Current Verification (cont.)**

Range of Verification Points (rms values)	Shunt
19 mA to 3.3 mA	Fluke A40 20 mA Shunt
30.0000 mA to 190 mA	Fluke A40 200 mA Shunt
300.000 mA to 2 A	Fluke A40 2A Shunt
2.99000 A to 20.0000 A	Fluke A40A 20A Shunt

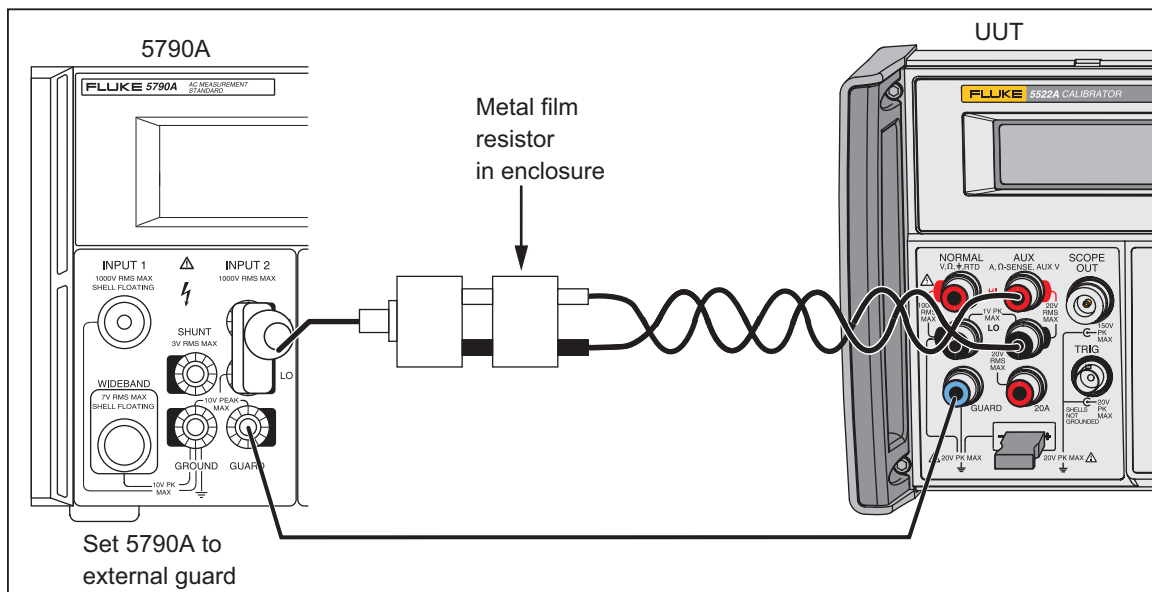

**Figure 3-15. AC Current Verification Connections with a Metal Film Resistor (3.299 mA and Lower)**

**Table 3-27. Verification Tests for AC Current**

Range	Output	Frequency	Low Limit	High Limit
329.99 $\mu$ A	33.00 $\mu$ A	1 kHz	32.87 $\mu$ A	33.13 $\mu$ A
329.99 $\mu$ A	33.00 $\mu$ A	10 kHz	32.60 $\mu$ A	33.40 $\mu$ A
329.99 $\mu$ A	33.00 $\mu$ A	30 kHz	32.20 $\mu$ A	33.80 $\mu$ A
329.99 $\mu$ A	190.00 $\mu$ A	45 Hz	189.71 $\mu$ A	190.29 $\mu$ A
329.99 $\mu$ A	190.00 $\mu$ A	1 kHz	189.71 $\mu$ A	190.29 $\mu$ A
329.99 $\mu$ A	190.00 $\mu$ A	10 kHz	188.66 $\mu$ A	191.34 $\mu$ A
329.99 $\mu$ A	190.00 $\mu$ A	30 kHz	187.32 $\mu$ A	192.68 $\mu$ A
329.99 $\mu$ A	329.00 $\mu$ A	10 Hz	328.37 $\mu$ A	329.63 $\mu$ A
329.99 $\mu$ A	329.00 $\mu$ A	45 Hz	328.57 $\mu$ A	329.43 $\mu$ A
329.99 $\mu$ A	329.00 $\mu$ A	1 kHz	328.57 $\mu$ A	329.43 $\mu$ A
329.99 $\mu$ A	329.00 $\mu$ A	5 kHz	328.03 $\mu$ A	329.97 $\mu$ A
329.99 $\mu$ A	329.00 $\mu$ A	10 kHz	326.83 $\mu$ A	331.17 $\mu$ A

Table 3-27. Verification Tests for AC Current (cont.)

Range	Output	Frequency	Low Limit	High Limit
329.99 $\mu$ A	329.00 $\mu$ A	30 kHz	324.65 $\mu$ A	333.35 $\mu$ A
3.2999 mA	0.3300 mA	1 kHz	0.3296 mA	0.3304 mA
3.2999 mA	0.3300 mA	5 kHz	0.3293 mA	0.3307 mA
3.2999 mA	0.3300 mA	30 kHz	0.3268 mA	0.3332 mA
3.2999 mA	1.9000 mA	1 kHz	1.8983 mA	1.9017 mA
3.2999 mA	1.9000 mA	10 kHz	1.8921 mA	1.9079 mA
3.2999 mA	1.9000 mA	30 kHz	1.8842 mA	1.9158 mA
3.2999 mA	3.2900 mA	10 Hz	3.2846 mA	3.2954 mA
3.2999 mA	3.2900 mA	45 Hz	3.2872 mA	3.2928 mA
3.2999 mA	3.2900 mA	1 kHz	3.2872 mA	3.2928 mA
3.2999 mA	3.2900 mA	5 kHz	3.2845 mA	3.2955 mA
3.2999 mA	3.2900 mA	10 kHz	3.2765 mA	3.3035 mA
3.2999 mA	3.2900 mA	30 kHz	3.2631 mA	3.3169 mA
32.999 mA	3.3000 mA	1 kHz	3.297 mA	3.303 mA
32.999 mA	3.3000 mA	5 kHz	3.296 mA	3.304 mA
32.999 mA	3.3000 mA	30 kHz	3.285 mA	3.315 mA
32.999 mA	19.0000 mA	1 kHz	18.991 mA	19.009 mA
32.999 mA	19.0000 mA	10 kHz	18.967 mA	19.033 mA
32.999 mA	19.0000 mA	30 kHz	18.935 mA	19.065 mA
32.999 mA	32.9000 mA	10 Hz	32.849 mA	32.951 mA
32.999 mA	32.9000 mA	1 kHz	32.886 mA	32.914 mA
32.999 mA	32.9000 mA	5 kHz	32.877 mA	32.923 mA
32.999 mA	32.9000 mA	10 kHz	32.844 mA	32.956 mA
32.999 mA	32.9000 mA	30 kHz	32.791 mA	33.009 mA
329.99 mA	33.0000 mA	1 kHz	32.97 mA	33.03 mA
329.99 mA	33.0000 mA	5 kHz	32.92 mA	33.08 mA
329.99 mA	33.0000 mA	30 kHz	32.69 mA	33.31 mA
329.99 mA	190.0000 mA	1 kHz	189.91 mA	190.09 mA
329.99 mA	190.0000 mA	10 kHz	189.60 mA	190.40 mA
329.99 mA	190.0000 mA	30 kHz	189.19 mA	190.81 mA
329.99 mA	329.0000 mA	10 Hz	328.49 mA	329.51 mA
329.99 mA	329.0000 mA	45 Hz	328.86 mA	329.14 mA
329.99 mA	329.0000 mA	1 kHz	328.86 mA	329.14 mA

**Table 3-27. Verification Tests for AC Current (cont.)**

Range	Output	Frequency	Low Limit	High Limit
329.99 mA	329.0000 mA	5 kHz	328.69 mA	329.31 mA
329.99 mA	329.0000 mA	10 kHz	328.37 mA	329.63 mA
329.99 mA	329.0000 mA	30 kHz	327.75 mA	330.25 mA
2.99999 A	0.33000 A	1 kHz	0.32978 A	0.33022 A
2.99999 A	0.33000 A	5 kHz	0.32735 A	0.33265 A
2.99999 A	0.33000 A	10 kHz	0.31840 A	0.34160 A
2.99999 A	1.09000 A	10 Hz	1.08827 A	1.09174 A
2.99999 A	1.09000 A	45 Hz	1.08951 A	1.09049 A
2.99999 A	1.09000 A	1 kHz	1.08951 A	1.09049 A
2.99999 A	1.09000 A	5 kHz	1.08355 A	1.09645 A
2.99999 A	1.09000 A	10 kHz	1.06320 A	1.11680 A
2.99999 A	2.99000 A	10 Hz	2.98542 A	2.99458 A
2.99999 A	2.99000 A	45 Hz	2.98840 A	2.99160 A
2.99999 A	2.99000 A	1 kHz	2.98840 A	2.99160 A
2.99999 A	2.99000 A	5 kHz	2.97405 A	3.00595 A
2.99999 A	2.99000 A	10 kHz	2.92520 A	3.05480 A
20.5000 A	3.3000 A	500 Hz	3.2954 A	3.3046 A
20.5000 A	3.3000 A	1 kHz	3.2954 A	3.3046 A
20.5000 A	3.3000 A	5 kHz	3.2155 A	3.3845 A
20.5000 A	10.9000 A	45 Hz	10.8926 A	10.9074 A
20.5000 A	10.9000 A	65 Hz	10.8926 A	10.9074 A
20.5000 A	10.9000 A	500 Hz	10.8893 A	10.9107 A
20.5000 A	10.9000 A	1 kHz	10.8893 A	10.9107 A
20.5000 A	10.9000 A	5 kHz	10.6255 A	11.1745 A
20.5000 A	20.0000 A	45 Hz	19.9750 A	20.0250 A
20.5000 A	20.0000 A	65 Hz	19.9750 A	20.0250 A
20.5000 A	20.0000 A	500 Hz	19.9690 A	20.0310 A
20.5000 A	20.0000 A	1 kHz	19.9690 A	20.0310 A
20.5000 A	20.0000 A	5 kHz	19.4950 A	20.5050 A

**Capacitance Verification**

Make sure the Calibrator outputs the current between the high and low limits shown in Table 3-28 Use the PM 6304C RCL Meter directly for capacitance values that are less than or equal to 109.000  $\mu$ F. For more than 109.000  $\mu$ F, you must use a timed charge up routine with a constant current source in order to achieve the necessary test uncertainty ratio.

To do a verification on capacitance more than 109.000  $\mu\text{F}$ , see the “200  $\mu\text{F}$  to 110 mF Capacitance Verification” section.

**Table 3-28. Verification Tests for Capacitance**

Range	Output	Test Frequency or Current	Low Limit	High Limit
0.3999 nF	0.2200 nF	1 kHz	0.2092 nF	0.2308 nF
0.3999 nF	0.3900 nF	1 kHz	0.3785 nF	0.4015 nF
1.0999 nF	0.4800 nF	1 kHz	0.4682 nF	0.4918 nF
1.0999 nF	0.6000 nF	1 kHz	0.5877 nF	0.6123 nF
1.0999 nF	1.0000 nF	1 kHz	0.9862 nF	1.0138 nF
3.2999 nF	2.0000 nF	1 kHz	1.9824 nF	2.0176 nF
10.9999 nF	7.0000 nF	1 kHz	6.9767 nF	7.0233 nF
10.9999 nF	10.9000 nF	1 kHz	10.8693 nF	10.9307 nF
32.9999 nF	20.0000 nF	1 kHz	19.8620 nF	20.1380 nF
109.999 nF	70.000 nF	1 kHz	69.767 nF	70.233 nF
109.999 nF	109.000 nF	1 kHz	108.693 nF	109.307 nF
329.999 nF	200.000 nF	1 kHz	199.320 nF	200.680 nF
329.999 nF	300.000 nF	1 kHz	299.130 nF	300.870 nF
1.09999 $\mu\text{F}$	0.70000 $\mu\text{F}$	100 Hz	0.69767 $\mu\text{F}$	0.70233 $\mu\text{F}$
1.09999 $\mu\text{F}$	1.09000 $\mu\text{F}$	100 Hz	1.08693 $\mu\text{F}$	1.09307 $\mu\text{F}$
3.29999 $\mu\text{F}$	2.00000 $\mu\text{F}$	100 Hz	1.99320 $\mu\text{F}$	2.00680 $\mu\text{F}$
3.29999 $\mu\text{F}$	3.00000 $\mu\text{F}$	100 Hz	2.99130 $\mu\text{F}$	3.00870 $\mu\text{F}$
10.9999 $\mu\text{F}$	7.0000 $\mu\text{F}$	100 Hz	6.9767 $\mu\text{F}$	7.0233 $\mu\text{F}$
10.9999 $\mu\text{F}$	10.9000 $\mu\text{F}$	100 Hz	10.8693 $\mu\text{F}$	10.9307 $\mu\text{F}$
32.9999 $\mu\text{F}$	20.0000 $\mu\text{F}$	100 Hz	19.9100 $\mu\text{F}$	20.0900 $\mu\text{F}$
32.9999 $\mu\text{F}$	30.0000 $\mu\text{F}$	100 Hz	29.8800 $\mu\text{F}$	30.1200 $\mu\text{F}$
109.999 $\mu\text{F}$	70.000 $\mu\text{F}$	50 Hz	69.662 $\mu\text{F}$	70.338 $\mu\text{F}$
109.999 $\mu\text{F}$	109.000 $\mu\text{F}$	50 Hz	108.529 $\mu\text{F}$	109.471 $\mu\text{F}$
329.999 $\mu\text{F}$	200.000 $\mu\text{F}$	54 $\mu\text{A}$ dc	199.020 $\mu\text{F}$	200.980 $\mu\text{F}$
329.999 $\mu\text{F}$	300.000 $\mu\text{F}$	80 $\mu\text{A}$ dc	298.680 $\mu\text{F}$	301.320 $\mu\text{F}$
1.09999 mF	0.33000 mF	90 $\mu\text{A}$ dc	0.32788 mF	0.33212 mF
1.09999 mF	0.70000 mF	180 $\mu\text{A}$ dc	0.69662 mF	0.70338 mF
1.09999 mF	1.09000 mF	270 $\mu\text{A}$ dc	1.08529 mF	1.09471 mF
3.2999 mF	1.1000 mF	270 $\mu\text{A}$ dc	1.0933 mF	1.1067 mF
3.2999 mF	2.0000 mF	540 $\mu\text{A}$ dc	1.9902 mF	2.0098 mF

**Table 3-28. Verification Tests for Capacitance (cont.)**

Range	Output	Test Frequency or Current	Low Limit	High Limit
3.2999 mF	3.0000 mF	800 $\mu$ A dc	2.9868 mF	3.0132 mF
10.9999 mF	3.3000 mF	900 $\mu$ A dc	3.2788 mF	3.3212 mF
10.9999 mF	10.9000 mF	2.7 mA dc	10.8529 mF	10.9471 mF
32.9999 mF	20.0000 mF	5.4 mA dc	19.8300 mF	20.1700 mF
32.9999 mF	30.0000 mF	8.0 mA dc	29.7600 mF	30.2400 mF
110.000 mF	33.000 mF	9.0 mA dc	32.570 mF	33.430 mF
110.000 mF	110.000 mF	27.0 mA dc	108.800 mF	111.200 mF

**200  $\mu$ F to 110 mF Capacitance Verification**

The calibrator can source capacitance values much larger than what most RCL meters can measure. To do capacitance verification on outputs from 200  $\mu$ F to 110 mF, a dc current from a precision current source and a high speed sampling digital multimeter is necessary.

**Capacitance Measurement**

By definition, capacitance is the product of an applied current and the ratio of the charge time to the charge voltage.

$$C = I * \frac{\Delta t}{\Delta v}$$

A measurement procedure for capacitance is to apply a known current across the capacitor and measure the voltage change for a known time interval.

**Table 3-29. Necessary Test Equipment for High-Value Capacitance Measurements**

Qty	Manufacturer	Model	Equipment
1	Fluke	5500A/LEADS	Test lead set
1	Hewlett-Packard	3458A	DMM
1	Fluke	5700A	Calibrator

Computer control of the instruments can remove the uncertainties found with manual control.

*Note*

*For this procedure, the amplitude of the current is chosen to limit compliance voltage across the capacitor under test to <3 V for the charge interval of 10 seconds. Refer to Table 3-28 for the dc current that is necessary for each capacitance value to be verified*

For less uncertainty, it is recommended that this procedure be done with computer control. See Figure 3-17 for an example Visual Basic program. If you wish to do this verification manually, the HP 3458A DMM can be programmed from its front panel to give the necessary timing and measurement storage. Please refer to the documentation for the HP 3458A for more information.

To measure high-end capacitance:

1. Connect the Fluke 5700A, 5522A, HP 3458A DMM and computer as shown in

Figure 3-16. See Table 3-29 for the necessary equipment.

2. Lock the HP 3458A in the 10 V dc range.
3. Set up the meter to make 100 samples at 1 ms-aperture width and a 100 ms sweep for a total of 10 seconds on a trigger command.
4. Type in the capacitance on the Calibrator.
5. Push **OPR**.
6. Type in the predetermined DCI level on the 5700A. Set the 5700A to Operate.
7. When the remote status indicator on the Calibrator shows a stable condition, your computer program will start the HP 3458A measurement sequence. Sense the voltage at the Calibrator output.
8. At the end of the measurement, set the 5700A to Standby and then retrieve the data from the HP 3458A.

*Note*

*If you operate manually, and you do not push the 5700A Standby key in a timely manner, the 5522A or 5700A will go to Standby. This is because of an overload condition. This will have no effect on the measurements made for the 10 second measurement period.*

9. The capacitance is calculated as the product of the dc current and the ratio of the time interval (10 seconds) divided by  $(V_{final} - V_{initial})$ .

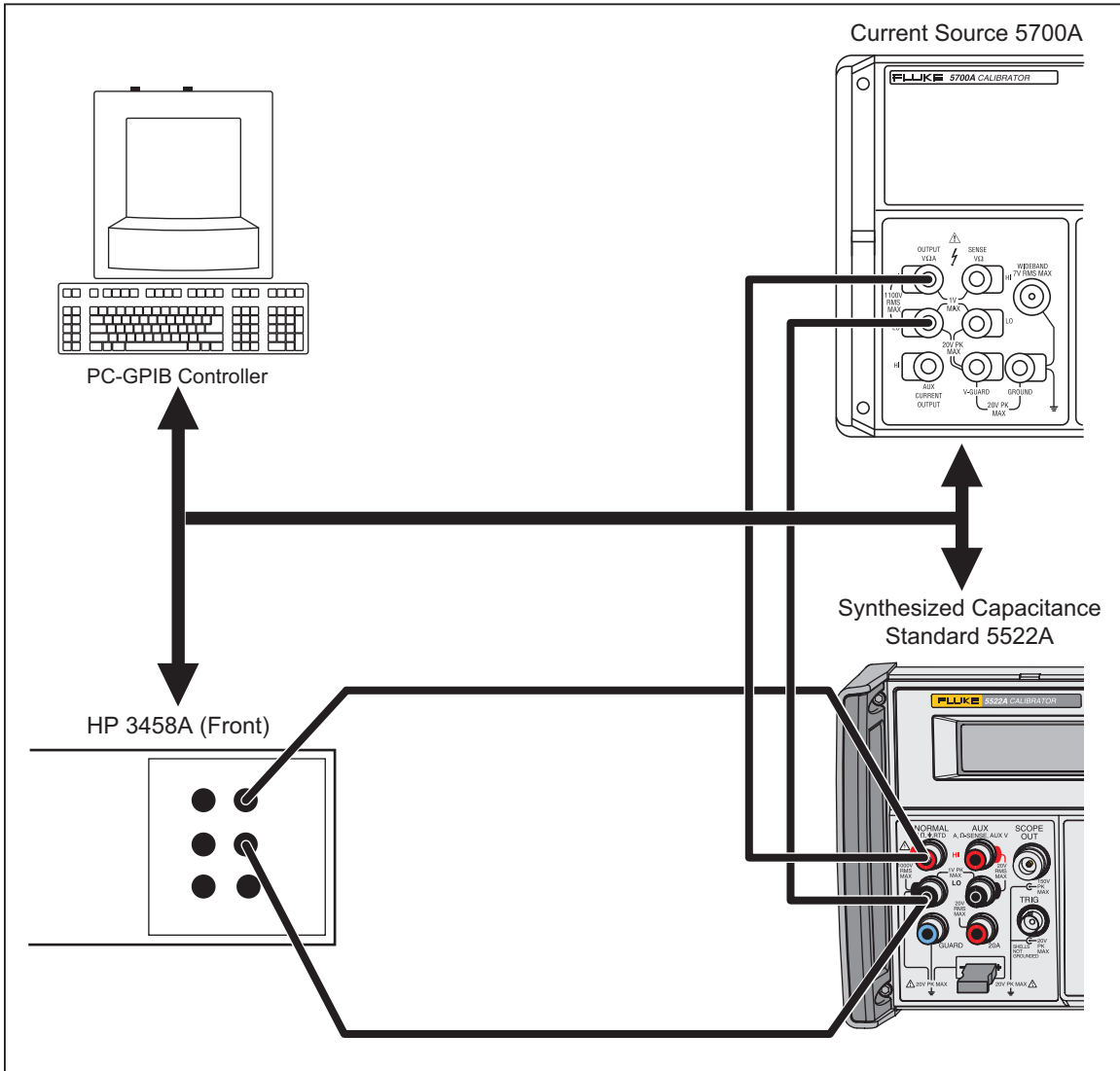

Figure 3-16. High-Value Capacitance Measurement Setup

gjh113.eps

```
'Initial 3458 Set-up:

errmsg = gpibPut(a_3458, "TARM HOLD; DCV 10; APER 1.0e-3; MEM FIFO; SWEEP 0.1, 100; END
ALWAYS")

-----

'5700 setup

If (range(stp) > .002) Then ' 1mF range with LCR Meter, 3mF range with I charge
' 3458 has already been set-up for measurement; now
' set up system 5700 for DCI output, set to OPERate
errmsg = gpibPut(a_5700, "CUR_POST AUX; OUT " + Str$(dci(stp)) + " A, 0 Hz")
srcSettled
errmsg = gpibPut(a_5700, "OPER")
srcSettled
Call trig_3458(stp)
errmsg = gpibPut(a_5700, "STBY")
End If

-----

Sub trig_3458 (stp As Integer)

Dim x As Integer, errmsg As String, response As String, no_samples As Integer, deltav
As Single
result = 0

' all of the voltage data is stuck into this array for optional regression analysis
Dim CapChan As Integer
CapChan = FreeFile
Open "C:\DATA\HICAP." & Format$(Str$(stp), "#") For Output As CapChan

' this triggers the readings and stores them internally in the 3458
errmsg = gpibPut(a_3458, "TARM SGL")

' retrieve the number of samples stored - loop until meter is finished taking samples
errmsg = gpibPut(a_3458, "MCOUNT?")
Do
response = Space$(80)
errmsg = gpibGet(a_3458, response)
Loop Until (Len(response) <> 0)
no_samples = Val(response)

' now retrieve the data and put into array
Print #CapChan, Val(response)
For x = 1 To no_samples
Do
response = Space$(80)
errmsg = gpibGet(a_3458, response)
```

Figure 3-17. Example Visual Basic Program

```

Loop Until (Len(response) <> 0)
    capdata(x) = Val(response)
    Print #CapChan, Val(response)
Next x
Close #CapChan

' throw out first and last reading, compute delta v
deltav = capdata(no_samples - 1) - capdata(2)

' dci() is the current; multiply by the charge time and divide product by change in
voltage
' charge time is (10 seconds - 2*100mS samples - 100mS for 0th sample)
result = (dci(stp) * 9.7) / deltav

End Sub

```

**Figure 3-17. Example Visual Basic Program (cont.)**

### Measurement Uncertainty

An example of how to calculate measurement uncertainty for a 3 mF verification is shown below.

Error Analysis Example: Capacitance test on 3 mF at 800  $\mu$ A

- 5700A DCI, 2.0 mA range: 50 ppm + 10 nA; at 800 A: 62.5 ppm.
- HP 3458A DCV, 10 V range: 4.1 ppm of measurement + 0.05 ppm of range.
- HP 3458A time base uncertainty: 100 ppm.
- UUT (Fluke 5522A) 3.0 mF: 0.44 %

While the HP 3458A dc volts accuracy is not specified for sample rates other than NPLC of 100, Fluke tests show the DMM is less than 25 ppm for the fast sample rate. 187.5 ppm (0.0187 %) when you add the error terms (62.5 ppm + 25 ppm + 100 ppm) for a test uncertainty ratio (TUR) > 20:1. The DMM has a number of other error sources. These are linearity, uncertainty on the 10 V range at 2 % of full scale, uncertainty in fast sample mode, and internal trigger timing uncertainty. Furthermore, the current source accuracy is contingent on the compliance voltage that changes continuously. Fluke tests were done to quantify each of these error sources, and none were found to contribute more than 0.02 %. This amount of error is not important, relative to the 5522A capacitance verification. See Table 3-28 for capacitance verification tests.

### Thermocouple Simulation Verification (Sourcing)

Make sure that the Calibrator outputs the temperatures between the high and low limits shown in Table 3-30. Use the 8508A DMM as the measurement device. Use copper connectors and copper wires.

**Table 3-30. Verification Tests for Thermocouple Simulation**

TC Type	Output, °C	Low Limit, mV	High Limit, mV
10 $\mu$ V/°C	0.00 °C (0.0000 mV)	-0.0030	0.0030
	100.00 °C (1.0000 mV)	0.99696	1.00304
	-100.00 °C (-1.0000 mV)	-1.00304	-.99696
	1000.00 °C (10.0000 mV)	9.99660	10.00340

**Table 3-30. Verification Tests for Thermocouple Simulation (cont.)**

TC Type	Output, °C	Low Limit, mV	High Limit, mV
10 µV/°C	-1000.00 °C (-10.0000 mV)	-10.0034	-9.9966
	10000.00 °C (100.0000 mV)	99.9930	100.0070
	-10000.00 °C (-100.0000 mV)	-100.0070	-99.9930

**Thermocouple Measurement Verification**

Make sure that the Calibrator outputs the temperatures between the high and low limits shown in Table 3-31. Use a Fluke 5500A Calibrator or equivalent instrument as the millivolt source, connected in parallel with an 8508A Reference Multimeter. At each verification point, use the 5500A error mode controls to adjust the calibrator output for a nominal measurement on the 8508A. Use copper connectors and copper wires.

**Table 3-31. Verification Tests for Thermocouple Measurement**

TC Type	Input, mV	Low Limit, °C	High Limit, °C
10 µV/°C	0.00 °C (0.0000 mV)	-0.30	0.30
	10000.00 °C (100.0000 mV)	9999.30	10000.70
	-10000.00 °C (-100.0000 mV)	-10000.70	-9999.30
	30000.00 °C (300.0000 mV)	29998.50	30001.50
	-30000.00 °C (-300.0000 mV)	-30001.50	-29998.50

**Phase Accuracy Verification, Volts and AUX Volts**

Make sure that the Calibrator outputs voltage at a phase between the high and low limits shown in Table 3-32. Use a precision phase meter as shown in Figure 3-13.

**Table 3-32. Verification Tests for Phase Accuracy, V and V**

Range, Normal Output, V	Output, Normal V	Frequency	Range, AUX Output	Output, AUX	Phase °	Low Limit	High Limit
3.29999	3.00000	65 Hz	3.29999 V	3.00000 V	0	-0.10	0.10
		400 Hz				-0.25	0.25
		1 kHz				-0.50	0.50
		5 kHz				-2.50	2.50
		10 kHz				-5.00	5.00
		30 kHz				-10.00	10.00
		65 Hz			60	59.90	60.10
		400 Hz				59.75	60.25
		1 kHz				59.50	60.50
		5 kHz				57.50	62.50
		10 kHz				55.00	65.00
		30 kHz				50.00	70.00
		65 Hz			90	89.90	90.10
		400 Hz				89.75	90.25
		1 kHz				89.50	90.50
		5 kHz				87.50	92.50
		10 kHz				85.00	95.00
		30 kHz				80.00	100.00
32.9999	30.0000	65 Hz				89.90	90.10
329.999	50.000	65 Hz				89.90	90.10

**Phase Accuracy Verification, Volts and Current**

Make sure that the Calibrator outputs voltage and current at a phase between the high and low limits shown in Table 3-33. Use a precision phase meter with a shunt as shown in Figure 3-14.

**Table 3-33. Verification Tests for Phase Accuracy, V and I**

Range, Normal Output	Output, Normal	Frequency	Range, AUX Output	Output, AUX	Phase °	Low Limit °	High Limit °
329.999 mV	30.000 mV	65 Hz	329.99 mA	300.00 mA	0	-0.10	0.10
329.999 mV	30.000 mV	1 kHz	329.99 mA	300.00 mA	0	-0.50	0.50
329.999 mV	30.000 mV	30 kHz	329.99 mA	300.00 mA	0	-10.00	10.00
329.999 mV	200.000 mV	65 Hz	2.99999 A	2.00000 A	0	-0.10	0.10
329.999 mV	50.000 mV	65 Hz	20.5000 A	5.0000 A	0	-0.10	0.10
329.999 mV	50.000 mV	400 Hz	20.5000 A	5.0000 A	0	-0.25	0.25
329.999 mV	30.000 mV	65 Hz	329.99 mA	300.00 mA	60	59.90	60.10
329.999 mV	200.000 mV	65 Hz	2.99999 A	2.00000 A	60	59.90	60.10
329.999 mV	200.000 mV	65 Hz	20.5000 A	20.0000 A	60	59.90	60.10
329.999 mV	200.000 mV	400 Hz	20.5000 A	20.0000 A	60	59.75	60.25
32.9999 V	3.3000 V	65 Hz	329.99 mA	300.00 mA	0	-0.10	0.10
32.9999 V	3.3000 V	65 Hz	2.99999 A	2.00000 A	0	-0.10	0.10
32.9999 V	3.3000 V	65 Hz	20.5000 A	5.0000 A	0	-0.10	0.10
32.9999 V	3.3000 V	400 Hz	20.5000 A	5.0000 A	0	-0.25	0.25
32.9999 V	3.3000 V	65 Hz	329.99 mA	300.00 mA	90	89.90	90.10
32.9999 V	3.3000 V	65 Hz	2.99999 A	2.00000 A	90	89.90	90.10
32.9999 V	3.3000 V	65 Hz	20.5000 A	20.0000 A	90	89.90	90.10
32.9999 V	3.3000 V	400 Hz	20.5000 A	20.0000 A	90	89.75	90.25
329.999 V	33.000 V	65 Hz	329.99 mA	300.00 mA	0	-0.10	0.10
329.999 V	33.000 V	65 Hz	2.99999 A	2.00000 A	0	-0.10	0.100
329.999 V	33.000 V	65 Hz	20.5000 A	5.0000 A	0	-0.10	0.10
329.999 V	33.000 V	400 Hz	20.5000 A	5.0000 A	0	-0.25	0.25
329.999 V	33.000 V	65 Hz	329.99 mA	300.00 mA	90	89.90	90.10
329.999 V	33.000 V	65 Hz	2.99999 A	2.00000 A	90	89.90	90.10
329.999 V	33.000 V	65 Hz	20.5000 A	20.0000 A	90	89.90	90.10
329.999 V	33.000 V	400 Hz	20.5000 A	20.0000 A	90	89.75	90.25

**Frequency Accuracy Verification**

Make sure that the Calibrator outputs voltage at the frequency between the high and low limits shown in Table 3-34. Use a Fluke PM6680B Frequency Counter.

**Table 3-34. Verification Tests for Frequency**

Range, Normal Output, V	Output, Normal, V	Frequency	Low Limit <sup>[1]</sup>	High Limit <sup>[1]</sup>
3.29999	3.00000	119.00 Hz	118.99970 Hz	119.00030 Hz
		120.0 Hz	119.99970 Hz	120.00030 Hz
		1000.0 Hz	999.9975 Hz	1000.0025 Hz
		100.00 kHz	99,999.75 Hz	100,000.25 Hz
[1] Frequency accuracy is specified for 1 year.				



# static awareness



A Message From  
Fluke Corporation

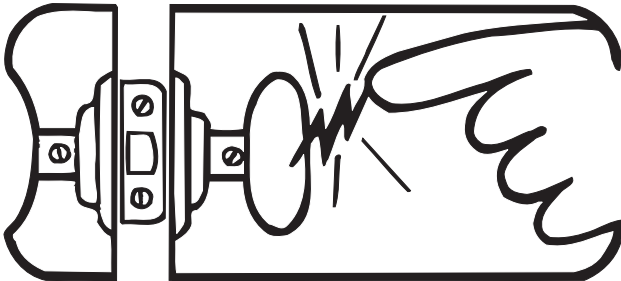

Some semiconductors and custom IC's can be damaged by electrostatic discharge during handling. This notice explains how you can minimize the chances of destroying such devices by:

1. Knowing that there is a problem.
2. Learning the guidelines for handling them.
3. Using the procedures, packaging, and bench techniques that are recommended.

The following practices should be followed to minimize damage to S.S. (static sensitive) devices.

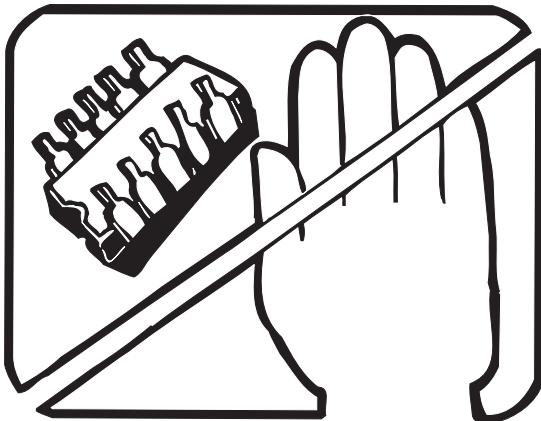

1. MINIMIZE HANDLING

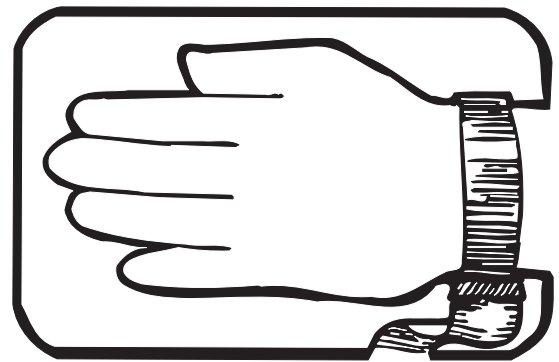

3. DISCHARGE PERSONAL STATIC BEFORE HANDLING DEVICES. USE A HIGH RESISTANCE GROUNDING WRIST STRAP.

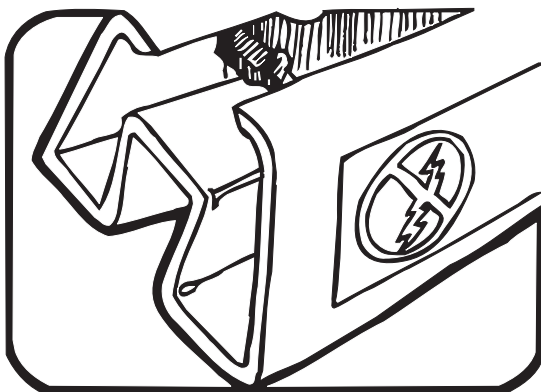

2. KEEP PARTS IN ORIGINAL CONTAINERS UNTIL READY FOR USE.

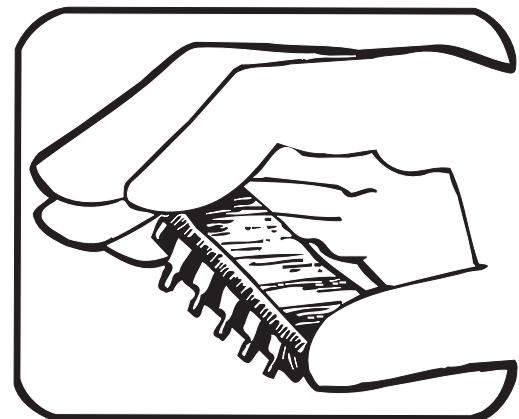

4. HANDLE S.S. DEVICES BY THE BODY.

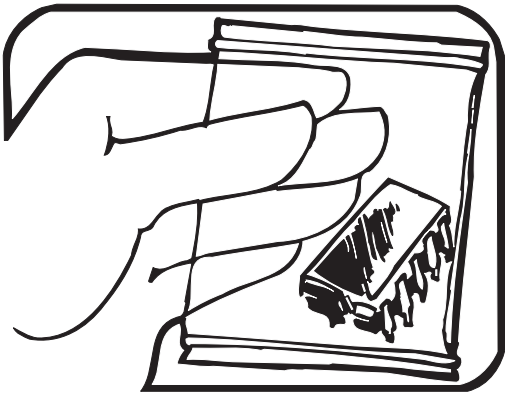

5. USE STATIC SHIELDING CONTAINERS FOR HANDLING AND TRANSPORT.

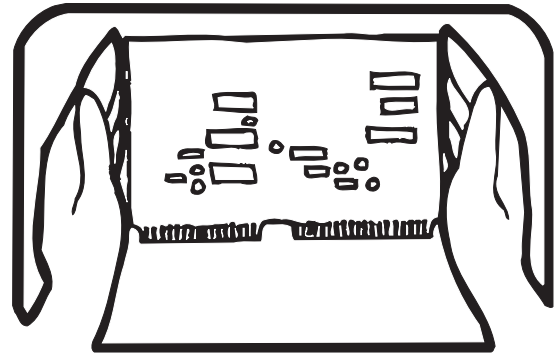

8. WHEN REMOVING PLUG-IN ASSEMBLIES HANDLE ONLY BY NON-CONDUCTIVE EDGES AND NEVER TOUCH OPEN EDGE CONNECTOR EXCEPT AT STATIC-FREE WORK STATION. PLACING SHORTING STRIPS ON EDGE CONNECTOR HELPS PROTECT INSTALLED S.S. DEVICES.

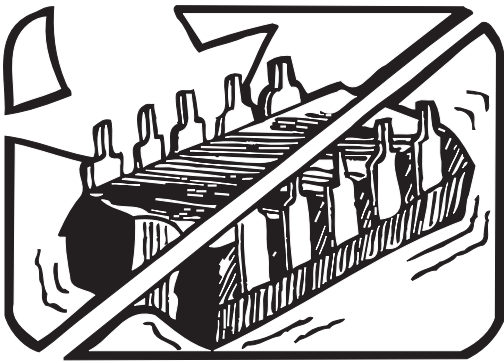

6. DO NOT SLIDE S.S. DEVICES OVER ANY SURFACE.

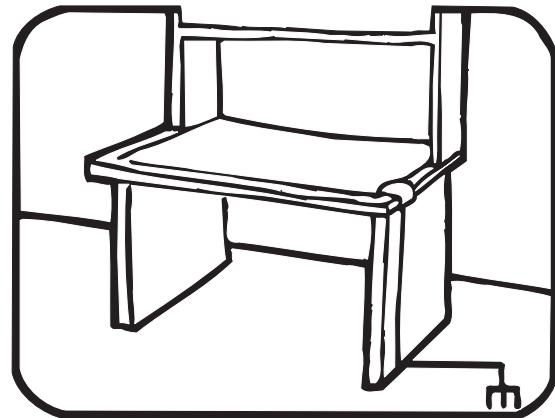

9. HANDLE S.S. DEVICES ONLY AT A STATIC-FREE WORK STATION.

10. ONLY ANTI-STATIC TYPE SOLDER-SUCKERS SHOULD BE USED.

11. ONLY GROUNDED-TIP SOLDERING IRONS SHOULD BE USED.

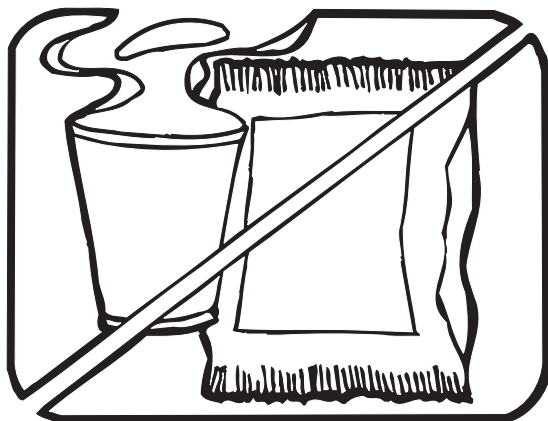

7. AVOID PLASTIC, VINYL AND STYROFOAM® IN WORK AREA.

PORTIONS REPRINTED  
WITH PERMISSION FROM TEKTRONIX INC.  
AND GERNER DYNAMICS, POMONA DIV.

# Chapter 4

## Maintenance

Title	Page
Introduction.....	4-3
Access Procedure.....	4-3
How to Remove Analog Modules.....	4-3
How to Remove the Main CPU (A9).....	4-3
How to Remove the Rear-Panel Assemblies.....	4-4
How to Remove the Filter PCA (A12).....	4-4
How to Remove the Encoder (A2) and Display PCAs.....	4-4
How to Remove the Keyboard and Access the Output Block.....	4-4
Diagnostic Tests.....	4-7
How to Do Diagnostic Tests.....	4-7
How to Test the Front Panel.....	4-7
Complete List of Error Messages.....	4-8



## Introduction

The Calibrator is a high performance instrument and it is not recommended that the user repair the boards to the component level. It is easy to introduce a subtle long-term stability problem when you touch the boards. Access procedures are supplied for those who must replace a defective module.

## Access Procedure

Use the procedures in this section to remove:

- Analog modules
- Main Central Processing Unit (CPU) (A9)
- Rear Panel Module (transformer and ac line input components)
- Filter PCA (A12)
- Encoder (A2) and display assemblies
- Keyboard PCA, and thermocouple I/O pca

## Remove Analog Modules

To remove the Voltage (A8), Current (A7), DDS (A6), or Synthesized Impedance (A5) modules:

1. Remove eight Phillips screws from the top cover.
2. Remove the top cover.
3. Remove eight Phillips screws from the guard box cover. The locations of the analog modules are printed on the guard box cover.
4. Lift off the guard box cover with the finger pull on the rear edge of the cover.
5. Release the board edge locks on the analog module to be removed.
6. Lift the board out of its socket in the Motherboard. Put the board shield side down.
7. To remove the shield, remove Phillips screw at the center of the shield, then pull the sides of the shield away from the board.
8. To install the shield, first align one set of tabs then push the other side into position.

## Main CPU (A9)

You can remove the Main CPU (A9) with the rear panel and Filter PCA (A12) installed. To remove the Main CPU PCA:

1. Remove the 3/16 inch jack screws from the SERIAL 1, SERIAL 2, and BOOST AMPLIFIER connectors.
2. Remove the 1/4 inch jack screws from the IEEE-488 connector.
3. Remove three Phillips screws from the right side of the rear panel.
4. Remove the ribbon cable from the Main CPU PCA (A9). There is not much room, but the cable is reachable.
5. Lift out the Main CPU PCA (A90).

### **Rear-Panel Assemblies**

To remove the transformer and the ac line input filter:

*Note*

*Figure 4-1 shows an exploded view of the rear-panel assemblies.*

1. Remove six Allen screws from the rear handles and then remove the handles.
2. Remove eight Phillips screws from the bottom cover.
3. Remove the bottom cover.
4. Remove the three Phillips screws that you access through holes in the bottom flange.
5. Remove the power switch pushrod.
6. Remove the rear panel. If the Main CPU (A9) is removed, then there are three large cables, plus one for fan power. If the Main CPU is installed, there is one more cable.

### **Filter PCA (A12)**

To remove the Filter PCA (A12):

1. Remove the top cover and guard-box cover. See the instructions in the “Remove Analog Modules” section.
2. Remove all the analog modules.
3. Remove the five Phillips screws from the front side of the rear guard box wall.
4. Lift out the Filter PCA.

### **Encoder (A2) PCA and Display Assembly**

To remove the Encoder PCA (A2) PCA and Display assembly:

*Note*

*Figure 4-2 shows an exploded view of the front-panel assemblies.*

1. Remove top and bottom covers.
2. With the bottom side up, disconnect all the cables that go to the front panel. One of these cables is attached by a cable tie that must be cut, then replaced with a new one when you assemble the Calibrator.
3. Remove six Allen screws from the two front handles. Then remove the handles.
4. Remove the front panel. The Encoder PCA (A2) and display pcas are now accessible.

### **Keyboard (A1) and Access the Output Block**

To remove the keyboard and access the output block:

1. Do all four steps in the “Encoder and Display” section.
2. Unlatch the plastic catches that fasten the front panel together.
3. Remove four Phillips screws that are around the output block.
4. Remove the output cables.
5. Pull apart the two main parts of the front panel.

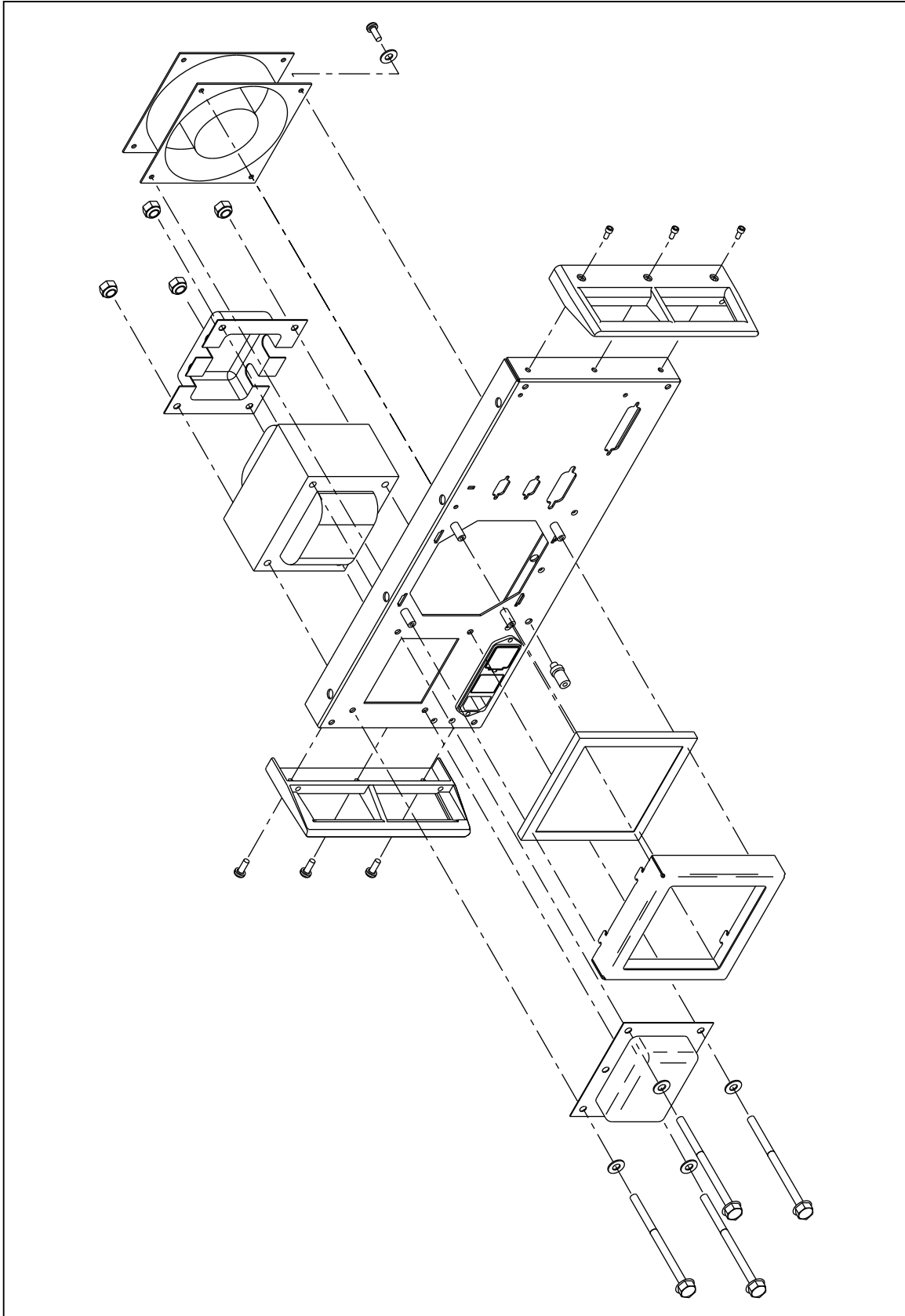

Figure 4-1. Exploded View of Rear-Panel Assemblies

om016f.eps

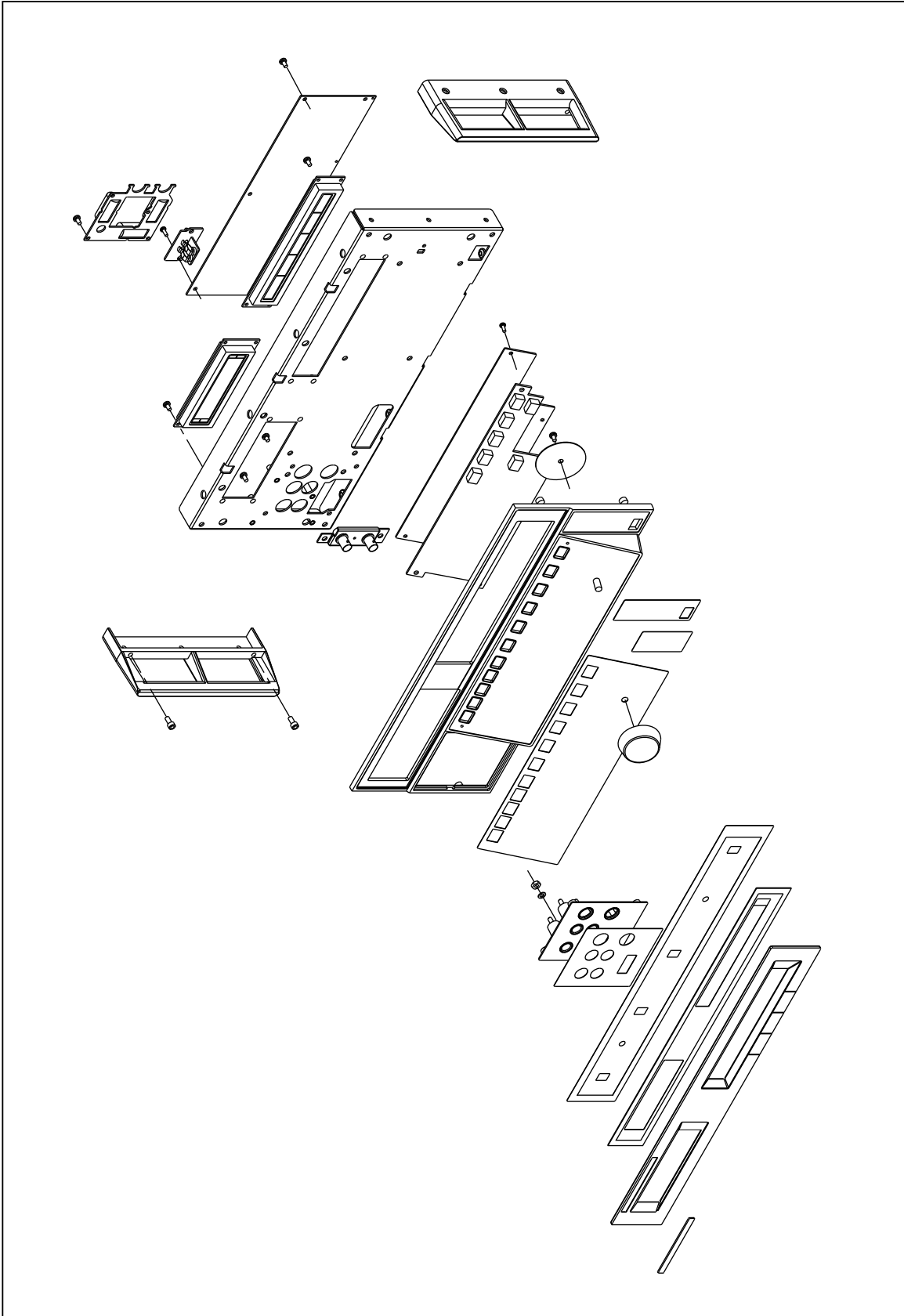

Figure 4-2. Exploded View of Front-Panel Assemblies

om017f.eps

## Diagnostic Tests

The Calibrator software has extensive self-test procedures. If self-test finds a malfunction, then use diagnostic tests to start fault isolation.

### Note

*Only do self-tests after the Calibrator has completed its warm-up.*

To access the diagnostic menus:

1. Push **SETUP**.
2. Push the **UTILITY FUNCTNS** softkey.
3. Push the **SELF TEST** softkey.

The menu shows:

- **DIAG** – Starts internal diagnostics
- **FRONT PANEL** – Lets you start the test for front panel knob, keys, bell, and displays.
- **SERIAL IF TEST** – Does a loopback test between the two serial ports. For this test, you must attach a straight-through serial cable between the two serial ports. Pins 2, 3, and 5 must be connected for this test.
- **DIGITAL TEST** – Does a test on the RAM and the bus on the Main CPU (A9).

### How to Do Diagnostic Tests

To do diagnostic tests:

1. Push **SETUP**.
2. Push the **UTILITY FUNCTNS** softkey.
3. Push the **SELF TEST** softkey. The menu shows **OPTIONS** and **GO ON**.
4. Push the **GO ON** softkey to start diagnostics.

The Calibrator instructs you to remove all cables from the front-panel outputs. Install a low-ohm copper short circuit across the **20A** and **AUX LO** terminals.

After you push the **GO ON** softkey, an automatic sequence of tests start. Diagnostics has a set of steps that are almost the same as the zero calibration and reports errors.

### How to Test the Front Panel

To test the front panel:

1. Push **SETUP**.
2. Push the **UTILITY FUNCTNS** softkey.
3. Push the **SELF TEST** softkey.
4. Push the **DIAG** softkey.

The menu shows:

**KNOB TEST** – Does a test on the knob encoder that shows a cursor that moves when you turn the knob.

**KEY TEST** – A test that shows the name of the key in the display when you push a key. Push **PREV MENU** to exit the test.

**BELL TEST** – Lets you operate the beeper for different periods of time.

**DISPLAY** – Turns on segments of the two displays. Push **RESET** to exit the test. With

Main software version 3.6, you can also push **PREV**, **STBY**, or **OPR** to exit the test.

*Note*

When you do a test on the output display (**DISPLAY MEAS**), you can select one of three test patterns: **ALLON**, **ALLOFF**, and **CURSOR TEST**.

## Complete List of Error Messages

Table 4-1 is a list of Calibrator error messages.

**Table 4-1. Error Message Format**

Error Number	(Message Class : Description)	Text Characters
0 to 65536	<b>QYE</b> Query Error, caused by a full input buffer, unterminated action or interrupted action	<b>F</b> Error is shown on the front panel as it occurs. Up to 36 text characters
	<b>DDE</b> Device-Specific Error, caused by some condition in the 5520A, for example, overrange	<b>R</b> Error is queued to the remote interface as it occurs
	<b>EXE</b> Execution Error, caused by an element external to, or inconsistent with, the 5522A	<b>S</b> Error causes instrument to go to Standby
	<b>CME</b> Command Error, caused by incorrect command syntax, unrecognized header, or parameter of the incorrect type	<b>D</b> Error causes instrument to go to the power up state
		(none) Error is sent to the initiator only (i.e., local initiator or remote initiator)

- 0 (QYE: ) No Error
- 1 (DDE:FR ) Error queue overflow
- 100 (DDE:FR D) Inguard not responding (send)
- 101 (DDE:FR D) Inguard not responding (recv)
- 102 (DDE:FR D) Lost sync with inguard
- 103 (DDE:FR ) Invalid guard xing command
- 104 (DDE:FR D) Hardware relay trip occurred
- 105 (DDE:FR D) Inguard got impatient
- 106 (DDE:FR D) A/D fell asleep
- 107 (DDE:FR D) Inguard watchdog timeout
- 108 (DDE:FR ) Inguard is obsolete
- 109 (DDE:FR D) Inguard parity error
- 110 (DDE:FR D) Inguard overrun error
- 111 (DDE:FR D) Inguard framing error
- 112 (DDE:FR D) Inguard fault error

113	(DDE:FR D)	Inguard fault input error
114	(DDE:FR D)	Inguard fault detect error
115	(DDE:FR D)	Inguard read/write error
300	(DDE: )	Invalid procedure number
301	(DDE: )	No such step in procedure
302	(DDE: )	Can't change that while busy
303	(DDE: )	Can't begin/resume cal there
304	(DDE: )	Wrong unit for reference
305	(DDE: )	Entered value out of bounds
306	(DDE: )	Not waiting for a reference
307	(DDE: )	Continue command ignored
308	(DDE:FR )	Cal constant outside limits
309	(DDE:FR )	Cal try to null failed
310	(DDE:FR D)	Sequence failed during cal
311	(DDE:FR D)	A/D measurement failed
312	(DDE:FR )	Invalid cal step parameter
313	(DDE: )	Cal switch must be ENABLED
314	(DDE:FR )	Divide by zero encountered
315	(DDE:FR )	Must be in OPER at this step
316	(DDE:FR )	Open thermocouple for RJ cal
317	(DDE:FR )	Bad reference Z or entry
318	(DDE:FR )	Cal takes DAC over top limit
319	(DDE: R )	Zero cal needed every 7 days
320	(DDE: R )	Ohms zero needed every 12 hours
398	(QYE:F )	Unusual cal fault %d
399	(QYE:F )	Fault during %s
400	(DDE:FR D)	Encoder not responding VERS
401	(DDE:FR D)	Encoder not responding COMM
402	(DDE:FR D)	Encoder not responding STAT
403	(DDE:FR )	Encoder self-test failed
405	(DDE:FR )	Message over display R side
406	(DDE:FR )	Unmappable character #0%d
407	(DDE:FR )	Encoder did not reset
408	(DDE:FR )	Encoder got invalid command
409	(DDE:FR D)	Encoder unexpectedly reset
500	(DDE: )	Internal state error
501	(DDE: )	Invalid keyword or choice
502	(DDE: )	Harmonic must be 1 - 50
503	(DDE: )	Frequency must be >= 0
504	(DDE: )	AC magnitude must be > 0
505	(DDE: )	Impedance must be >= 0
506	(DDE: )	Function not available
507	(DDE: )	Value not available
508	(DDE: )	Cannot enter watts by itself
509	(DDE: )	Output exceeds user limits
510	(DDE: )	Duty cycle must be 1.0-99.0
511	(DDE: )	Power factor must be 0.0-1.0
512	(DDE: )	Can't select that field now
513	(DDE: )	Edit digit out of range
514	(DDE: )	Can't switch edit field now
515	(DDE: )	Not editing output now
516	(DDE: )	dBm only for single sine ACV

517 (DDE: ) Freq too high for non-sine  
518 (DDE: ) Value outside locked range  
519 (DDE: ) Must specify an output unit  
520 (DDE: ) Can't do two freqs at once  
521 (DDE: ) Can't source 3 values at once  
522 (DDE: ) Temp must be degrees C or F  
523 (DDE: ) Can't do that now  
526 (DDE: ) Limit too small or large  
527 (DDE: ) No changes except RESET now  
528 (DDE: ) Offset out of range  
529 (DDE: ) Cannot edit to or from 0 Hz  
530 (DDE: ) Bad state image - not loaded  
531 (DDE: ) TC offset limited to +/-500 C  
532 (DDE: ) Can't go to STBY in Meas TC  
533 (DDE: ) Can't set an offset now  
534 (DDE: ) Can't lock this range  
535 (DDE: ) Can't set phase or PF now  
536 (DDE: ) Can't set wave now  
537 (DDE: ) Can't set harmonic now  
538 (DDE: ) Can't change duty cycle now  
539 (DDE: ) Can't change compensation now  
540 (DDE:FR ) Current OUTPUT moved to 5725A  
541 (DDE: ) TC ref must be valid TC temp  
542 (DDE: ) Can't turn EARTH on now  
543 (DDE: D) STA couldn't update OTD  
544 (DDE: ) Can't enter W with non-sine  
545 (DDE: ) Can't edit now  
546 (DDE: ) Can't set trigger to that now  
547 (DDE: ) Can't set output imp. now  
548 (DDE:FR ) Compensation is now OFF  
549 (DDE: ) Period must be  $\geq 0$   
550 (DDE: ) A report is already printing  
551 (DDE: ) ScopeCal option not installed  
552 (DDE: ) Not a ScopeCal function  
553 (DDE: ) Can't set marker shape now  
554 (DDE: ) Can't set video parameter now  
555 (DDE: ) Marker location out of range  
556 (DDE: ) Pulse width must be 1 - 255  
557 (DDE: ) Can't set range directly now  
558 (DDE: ) Not a range for this function  
559 (DDE: ) Can't set TD pulse now  
560 (DDE: ) ZERO\_MEAS only for C or PRES meas  
561 (DDE:FR ) That requires a -SC option  
562 (DDE:FR ) That requires a -SC600 option  
563 (DDE: ) Time limit must be 1s-60s  
564 (DDE: ) Can't set ref. phase now  
565 (DDE: ) ZERO\_MEAS reading not valid  
566 (DDE: ) Can't set dampen now  
567 (DDE: ) Can't turn EXGRD on now  
600 (DDE:FR D) Outguard watchdog timeout  
601 (DDE:FR ) Power-up RAM test failed  
602 (DDE:FR ) Power-up GPIB test failed

700	(DDE: R )	Saving to NV memory failed
701	(DDE: R )	NV memory invalid
702	(DDE: R )	NV invalid so default loaded
703	(DDE: R )	NV obsolete so default loaded
800	(DDE:FR )	Serial parity error %s
801	(DDE:FR )	Serial framing error %s
802	(DDE:FR )	Serial overrun error %s
803	(DDE:FR )	Serial characters dropped %s
900	(DDE:FR )	Report timeout - aborted
1000	(DDE:FR )	Sequence failed during diag
1200	(DDE:FR )	Sequence name too long
1201	(DDE:FR )	Sequence RAM table full
1202	(DDE:FR )	Sequence name table full
1300	(CME: R )	Bad syntax
1301	(CME: R )	Unknown command
1302	(CME: R )	Bad parameter count
1303	(CME: R )	Bad keyword
1304	(CME: R )	Bad parameter type
1305	(CME: R )	Bad parameter unit
1306	(EXE: R )	Bad parameter value
1307	(QYE: R )	488.2 I/O deadlock
1308	(QYE: R )	488.2 interrupted query
1309	(QYE: R )	488.2 unterminated command
1310	(QYE: R )	488.2 query after indefinite response
1311	(DDE: R )	Invalid from GPIB interface
1312	(DDE: R )	Invalid from serial interface
1313	(DDE: R )	Service only
1314	(EXE: R )	Parameter too long
1315	(CME: R )	Invalid device trigger
1316	(EXE: R )	Device trigger recursion
1317	(CME: R )	Serial buffer full
1318	(EXE: R )	Bad number
1319	(EXE: R )	Service command failed
1320	(CME: R )	Bad binary number
1321	(CME: R )	Bad binary block
1322	(CME: R )	Bad character
1323	(CME: R )	Bad decimal number
1324	(CME: R )	Exponent magnitude too large
1325	(CME: R )	Bad hexadecimal block
1326	(CME: R )	Bad hexadecimal number
1328	(CME: R )	Bad octal number
1329	(CME: R )	Too many characters
1330	(CME: R )	Bad string
1331	(DDE: R )	OPER not allowed while error pending
1332	(CME:FR )	Can't change UUT settings now
1500	(DDE:FRS )	Compliance voltage exceeded
1501	(DDE:FRS )	Shunt amp over or underload
1502	(DDE:FRS )	Current Amp Thermal Limit Exceeded
1503	(DDE:FRS )	Output current lim exceeded
1504	(DDE:FRS )	Input V or A limit exceeded
1505	(DDE:FRS )	VDAC counts out of range
1506	(DDE:FRS )	IDAC counts out of range

1507	(DDE:FRS )	AC scale dac counts out of range
1508	(DDE:FRS )	DC scale dac counts out of range
1509	(DDE:FRS )	Frequency dac counts out of range
1510	(DDE:FRS )	IDAC counts (DC OFFSET) out of range
1511	(DDE:FRS )	ZDAC counts out of range
1512	(DDE:FRS )	Can't read External Clock register
1513	(DDE:FRS )	External Clock too Fast
1514	(DDE:FRS )	External Clock too Slow
1515	(DDE:FR D)	Can't load waveform for scope mode
1600	(DDE:FR D)	OPM transition error
1601	(DDE:FR D)	TC measurement fault
1602	(DDE:FR D)	Z measurement fault
65535	(DDE:FR )	Unknown error %d

**Chapter 5**  
**List of Replaceable Parts**

<b>Title</b>	<b>Page</b>
Introduction.....	5-3
How to Obtain Parts.....	5-3



## Introduction

This chapter contains an illustrated list of replaceable parts for the Calibrator. Parts are shown by assembly, alphabetized by reference designator. Each assembly is accompanied by an illustration that shows the location of each part and its reference designator.

The parts lists contain:

- Reference designator (for example, “R52”)
- An indication if the part is subject to damage by static discharge (\* near the part description)
- Description
- Fluke part number
- Total quantity
- Special notes (factory-selected part for example)

### Caution

**A \* symbol shows a device that may be damaged by static discharge.**

## How to Obtain Parts

Electronic components may be ordered directly from the Fluke Corporation and its authorized representatives with the Fluke part number. Parts price information is available from the Fluke Corporation or its representatives. Refer to Tables 5-1 through 5-5.

To contact Fluke Calibration, call one of the following telephone numbers:

- Technical Support USA: 1-877-355-3225
- Calibration/Repair USA: 1-877-355-3225
- Canada: 1-800-36-FLUKE (1-800-363-5853)
- Europe: +31-40-2675-200
- Japan: +81-3-6714-3114
- Singapore: +65-6799-5566
- China: +86-400-810-3435
- Brazil: +55-11-3759-7600
- Anywhere in the world: +1-425-446-6110

In the event the part ordered has been replaced by a new or improved part, the replacement will be accompanied by an explanatory note and installation instructions, if necessary.

To make sure you get prompt delivery of the correct part, include in your order:

- Instrument model and serial number
- Part number and revision level of the pca (printed circuit assembly) that contains the part.
- Reference designator
- Fluke part number
- Description (as given under the Description heading)
- Quantity

Table 5-1. Front-Panel Assembly

Reference Designator	Description	Fluke Part Number	Quantity
A1	KEYBOARD BURN-IN A1	760868	1
A2	SUB - ASSEMBLY, ENCODER, A2	627232	1
A10	PCA, TC BUTTON, A10	4104614	1
A11	PCA, TC CONNECTION, A11	625951	1
H14-H33	SCREW, 8-32, .375, LO CAP, SCKT, STAINLESS STEEL, BLK OXIDE, LOCK	295105	20
H34-H42	SCREW, 5-20, .312, WASHER HEAD, PHILLIPS, STEEL, ZINC-CHROMATE, HI-LO THD FORM	494641	9
H65-H82	SCREW, PH, P, LOCK, SS, 6-32, .500	320051	18
H90-H101	WASHER, LOW THERMAL #8	859939	12
H101-H112	NUT, LOW THERMAL, 8-32	850334	12
H122-H151	SCREW, 6-32, .250, PAN, PHILLIPS, STEEL, ZINC-CLEAR, LOCK	152140	30
H158-H160	BINDING POST-RED	886382	3
H161-H164	SCREW, 6-32, .625, PAN, PHILLIPS, STEEL, ZINC-CLEAR, LOCK	152181	4
J1	CONNECTOR, ADAPTER, COAXIAL, N(F), SMA(F), BULKHEAD MOUNT, BULK	1279066	1
J2	CONNECTOR, CONN, COAX, BNC(F), CABLE	412858	1
MP3	FRONT PANEL, MODIFIED	1593149	1
MP4	HANDLE, 4U	3468705	4
MP5	BEZEL, FRONT PANEL	3843715	1
MP6	SHEET METAL KIT - 5522A	3834644	1
MP9	OUTPUT BLOCK	1278803	1
MP13	LCD MODULE, 5500A, 16X2 CHARACTER, STN, GRAY, TRANSFLECTIVE, YEL-GRN	929179	1
MP14	LCD MODULE, 5500A, 40X2 CHARACTER, STN, GRAY, TRANSFLECTIVE, YEL-GRN	929182	1
MP16	GASKET TAPE, FOAM, VINYL, .500, .062	282152	1
MP20	BINDING POST-BLUE	886366	1
MP21	BINDING POST-BLACK	886379	2
MP24	KEYPAD, ELASTOMERIC	1586668	1
MP25	DECAL, OUTPUT BLOCK, JASPER	1274401	1
MP26	LENS, BEZEL	945246	1
MP27	DECAL, POWER ON/OFF	886312	1
MP28	DECAL, KEYPAD	886304	1

**Table 5-1. Front-Panel Assembly (cont.)**

Reference Designator	Description	Fluke Part Number	Quantity
MP29	ENCODER WHEEL	764548	1
MP30	KNOB, ENCODER, GREY	868794	1
MP32	CORE, FERRITE, FLAT CABLE, 2.0W, 235 OHMS	643814	2
MP33	CLIP, FLAT CABLE FERRITE CORE	643822	2
MP35, MP36	GASKET, FRONT PANEL	627072	2
MP39	GASKET, CONDUCTIVE	627064	1
MP41	GROMMET, EXTRUDED, POLYETHYLENE, .085	854351	1
MP42	ADHESIVE, BEZEL	945258	1
MP43	NAMEPLATE - 5522A	3834667	1
MP45	GROMMET, SLOT, RUBBER, .406, .062	501593	1
MP48	CLAMP, CABLE, .50 ID, ADHESIVE MOUNT	688629	1
MP55, MP56	FOAM PAD, URETHANE, .312 W, .625 L, .375 THK, ADHESIVE	107687	2
W2	CABLE, OUTPUT TO MOTHER BOARD	3841106	1
W2	CABLE ACCESSORY, CABLE ACCESS, TIE, 11.00L, .19W, 3.00 DIA	501734	1

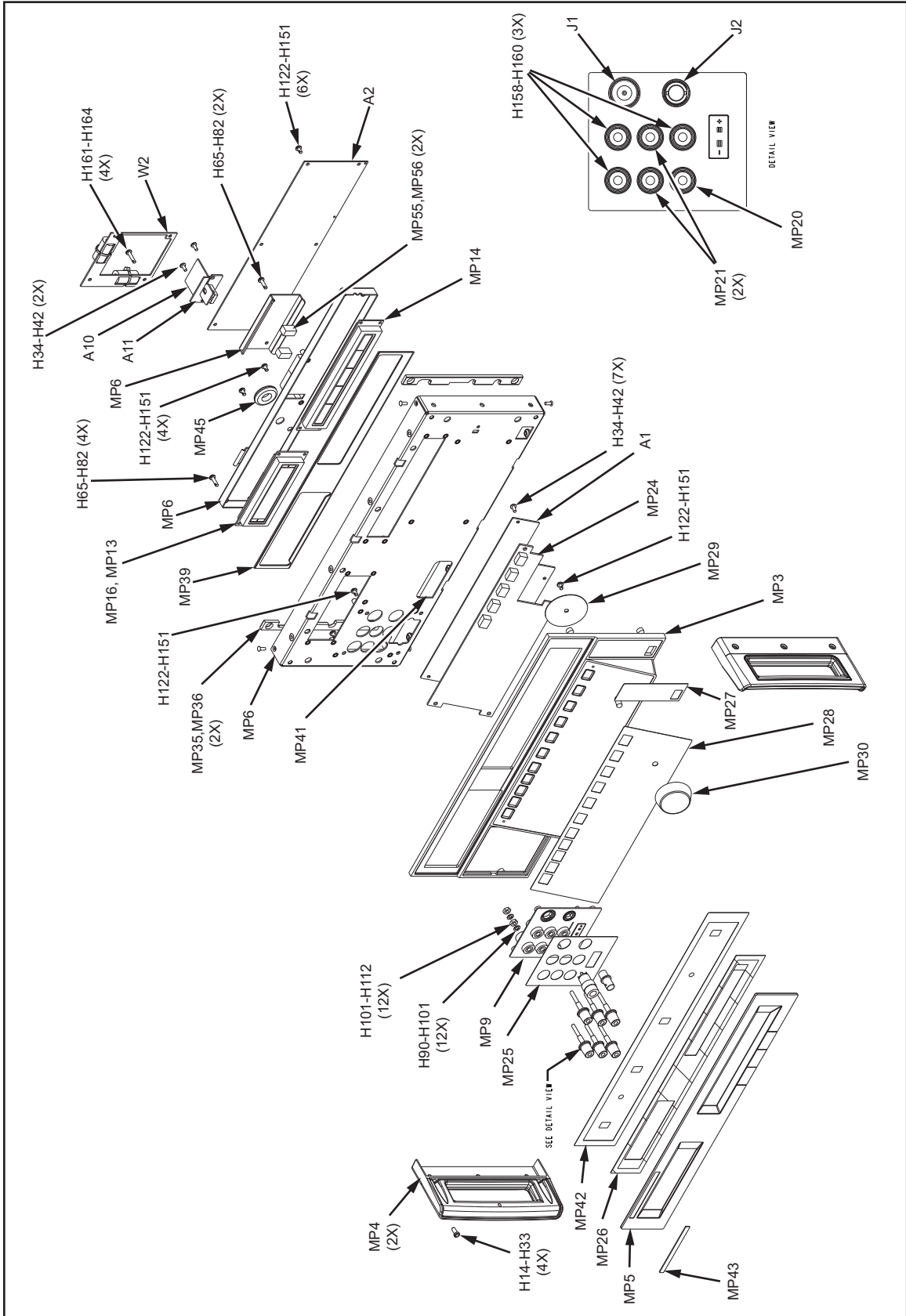

Figure 5-1. Front-Panel Assembly

gjh200.eps

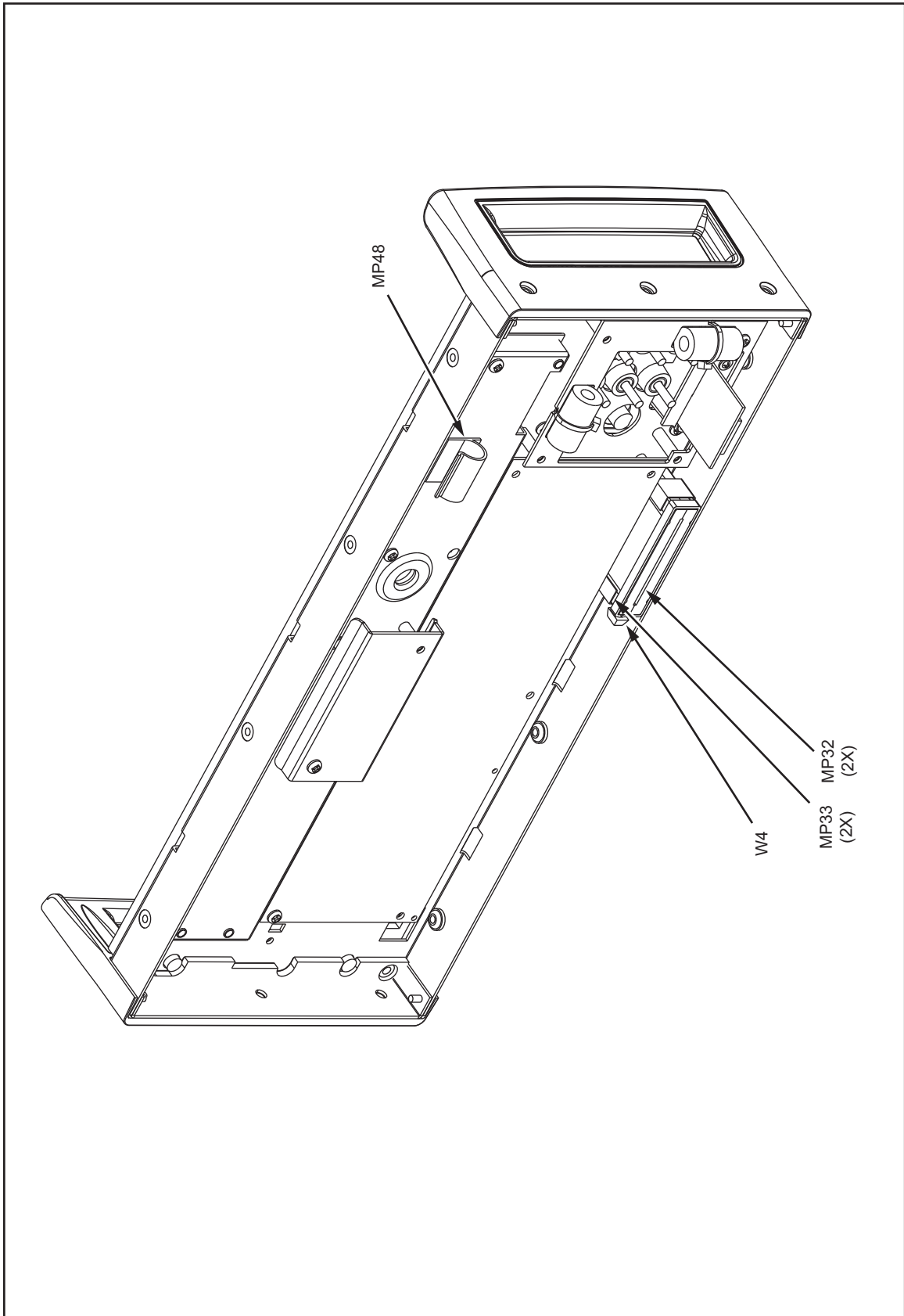

Figure 5-1. Front-Panel Assembly (cont.)

gjh201.eps

Table 5-2. Rear-Panel Assembly

Reference Designator	Description	Fluke Part Number	Quantity
A9	PCA, OUT-GUARD, CPU A9	3931491	1
B1	FAN ASSEMBLY	843029	1
F1	FUSE, .25X1.25, 2.5A, 250V, SLOW	851931	1
H5	WASHER, LOCK, INTRNL, STL, .267ID	110817	1
H6, H7	CONNECTOR ACC, CONN ACC, COAX, BNC, LOCKWASHER	622743	2
H8, H9	CONNECTOR ACC, CONN ACC, COAX, BNC, NUT	622719	2
H10-H13	WASHER, FLAT, STL, .170, .375, .031	110288	4
H14-H33	SCREW, 8-32, .375, LO CAP, SCKT, STAINLESS STEEL, BLK OXIDE, LOCK	295105	20
H83, H84	CONNECTOR ACCESSORY, D-SUB JACK SCREW, 4-40, .250 L, W/FLAT WASHER	1777348	2
H85, H86	CONNECTOR ACCESSORY, MICRO-RIBBON, SCREW LOCK, M3.5, 6-32, STEEL, ZINC-BLACK OR -CLEAR	854737	2
H87, H88, H89	WASHER, FLAT, STL, .160, .281, .010	111005	3
H102, H103	WASHER, FLAT, SS, .174, .375, .030	176743	2
H104	NUT, HEX, BR, 1/4-28	110619	1
H104-H107	SCREW, CAP, SCKT, STL, LOCK, 6-32, .750	944772	4
H108-H111	SCREW, MODIFIED	660933	4
H112-H115	NUT, HEX, ELASTIC STOP, STL, 10-32, .375	944350	4
H116-H119	SCREW, FHU, P, SS, 6-32, .312	867234	4
H120, H121	WASHER, FLAT, STL, .191, .289, .010	111047	2
H122-H151	SCREW, 6-32, .250, PAN, PHILLIPS, STEEL, ZINC-CLEAR, LOCK	152140	30
H152, H153	NUT, EXT LOCK, STL, 8-32	195263	2
H154-H157	WASHER, FLAT, .219 ID, .506 OD, .061 THK, STEEL, ZINC-CHROMATE	2565513	4
MP4	HANDLE, 4U	3468705	4
MP5	BEZEL, FRONT PANEL	3843715	1
MP6	SHEET METAL KIT - 5522A	3834644	1
MP18	FUSE, .25X1.25, 5A, 250V, SLOW	109215	1
MP19	SHIM, TRANSFORMER	625985	1
MP34	FILTER, LINE, 250VAC, 4A, W/ENTRY MODULE	944269	1
MP37	BINDING HEAD, PLATED	102889	1
MP38	BINDING POST, STUD, PLATED	102707	1

**Table 5-2. Rear-Panel Assembly (cont.)**

<b>Reference Designator</b>	<b>Description</b>	<b>Fluke Part Number</b>	<b>Quantity</b>
MP40	LABEL, CALIB, CERTIFICATION SEAL	802306	2
MP44	AIR FILTER	945287	1
MP49	FILTER PART, FILTER, LINE, PART, FUSE DRWR W/SHRT BAR	944277	1
MP50	FILTER PART, FILTER, LINE, PART, VOLTAGE SELECTOR	944272	1
T1	TRANSFORMER, POWER, 100-240V, 50/60HZ, 7:1:2:1:8:2:1:2, 5520A-6501, 284W, EI175	625720	1

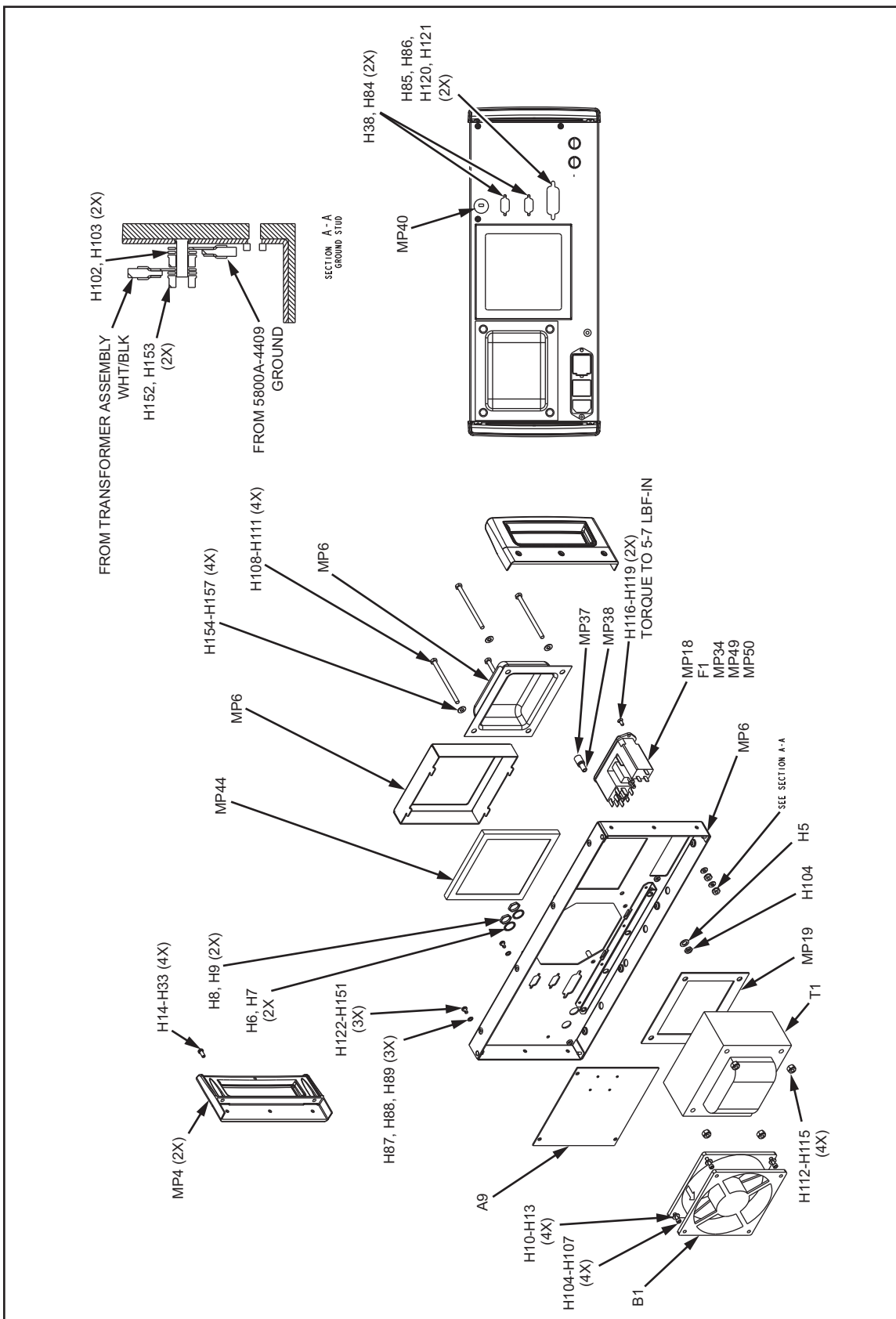

Figure 5-2. Rear-Panel Assembly

gjh202.eps

**Table 5-3. Chassis Assembly**

Reference Designator	Description	Fluke Part Number	Quantity
A3	PCA, MOTHER BOARD, A3	4104587	1
A5	PCA, OHMS, A5	4104593	1
A6	PCA, DDS, A6	4104606	1
A7	PCA, CURRENT. A7	626918	1
A8	PCB, VOLTAGE, A8	626926	1
A12	PCA, POWER SUPPLY, A12	4018083	1
H1-H4	140102, SCREW, M3X0.5, 8MM, PAN, PHILLIP, STEEL, ZN-CHROMATE	2803610	4
H14-H33	SCREW, 8-32, .375, LO CAP, SCKT, STAINLESS STEEL, BLK OXIDE, LOCK	295105	20
H43-H64	SCREW, FHU, P, LOCK, MAG SS, 6-32, .250	320093	22
H65-H82	SCREW, PH, P, LOCK, SS, 6-32, .500	320051	18
H116-H119	SCREW, FHU, P, SS, 6-32, .312	867234	4
H122-H151	SCREW, 6-32, .250, PAN, PHILLIPS, STEEL, ZINC-CLEAR, LOCK	152140	30
MP1, MP2	SHOCK ABSORBER	878983	2
MP3	SHIELD, MUMETAL	1552023	1
MP6	SHEET METAL KIT - 5522A	3834644	1
MP7	PUSH ROD	1275879	1
MP11	RETAINER, ANALOG TOPCOVER	3472691	2
MP12	EXTRUSION, SIDE	937271	2
MP15	INSERT, PLASTIC SIDE	937276	2
MP22	GROUND STRIP, BECU FINGERS, ADHES, .32 W, 12.5 L	601762	4
MP31	EJECTOR, PCB CARD EJECTOR, NYLON, ACCEPTS PCB THICKNESS 1/16 IN, UP TO 3/32 IN, WHITE	494724	4
MP46	POWER BUTTON, ON/OFF	775338	1
MP51	GROUND STRIP, GRND STRIP, CU FINGERS, .32, 12.50	601770	4
MP54	AIDE, PCB PULL	541730	1
MP57	TAPE, FOAM, POLYUR, W/LINER, .3125, .250	603134	1

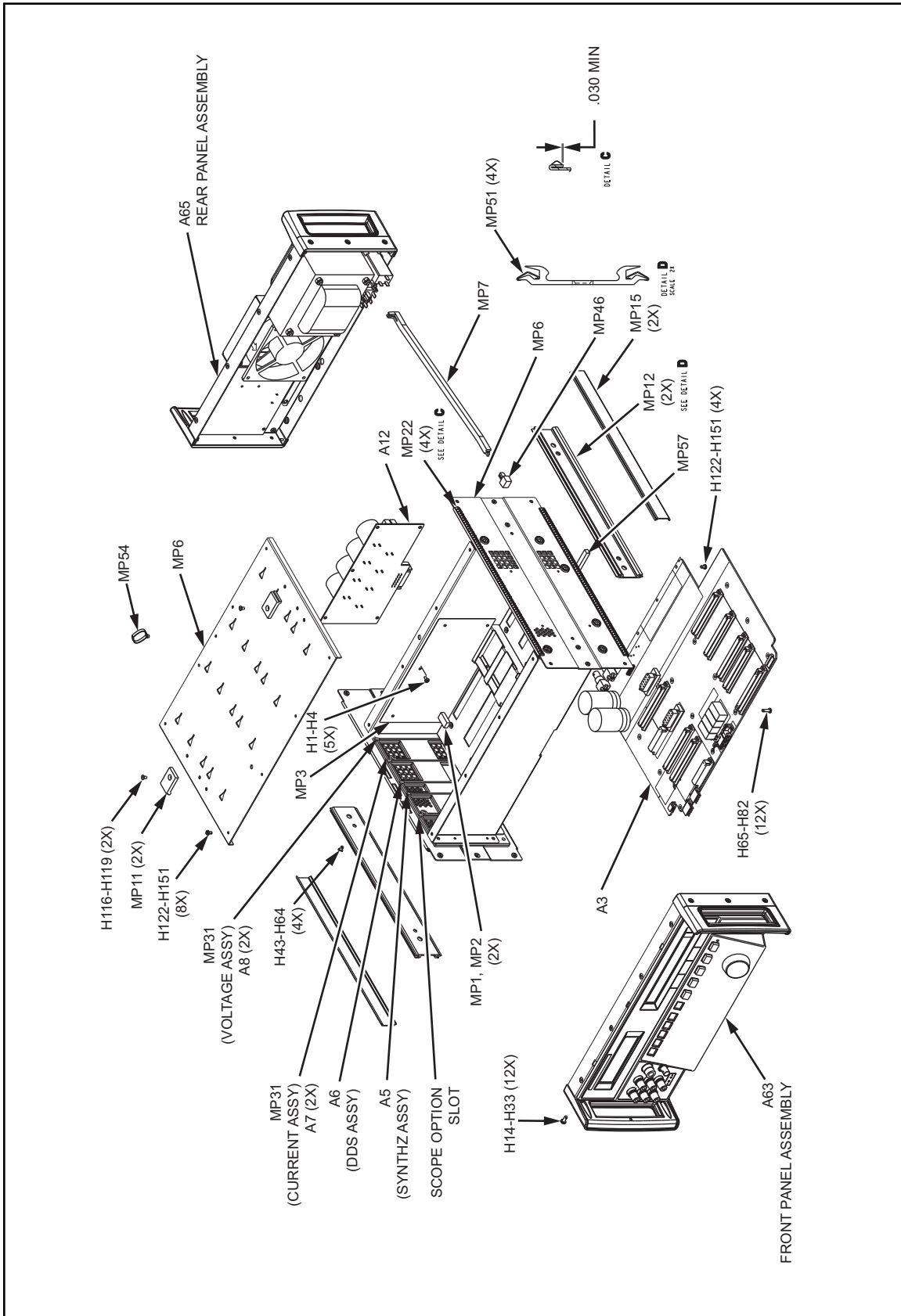

Figure 5-3. Chassis Assembly

gjh203.eps

**Table 5-4. Wiring**

<b>Reference Designator</b>	<b>Description</b>	<b>Fluke Part Number</b>	<b>Quantity</b>
MP52	LABEL, MYLAR, GROUND SYMBOL	911388	1
W1	LABEL, MYLAR, GROUND SYMBOL	172080	2
W2	CABLE, 20AMP OUTPUT	3473928	1
W3	WIRE, 6 GROUND"	626116	1
W5	CABLE, 14 PIN SIP, OPTREX	1572102	1

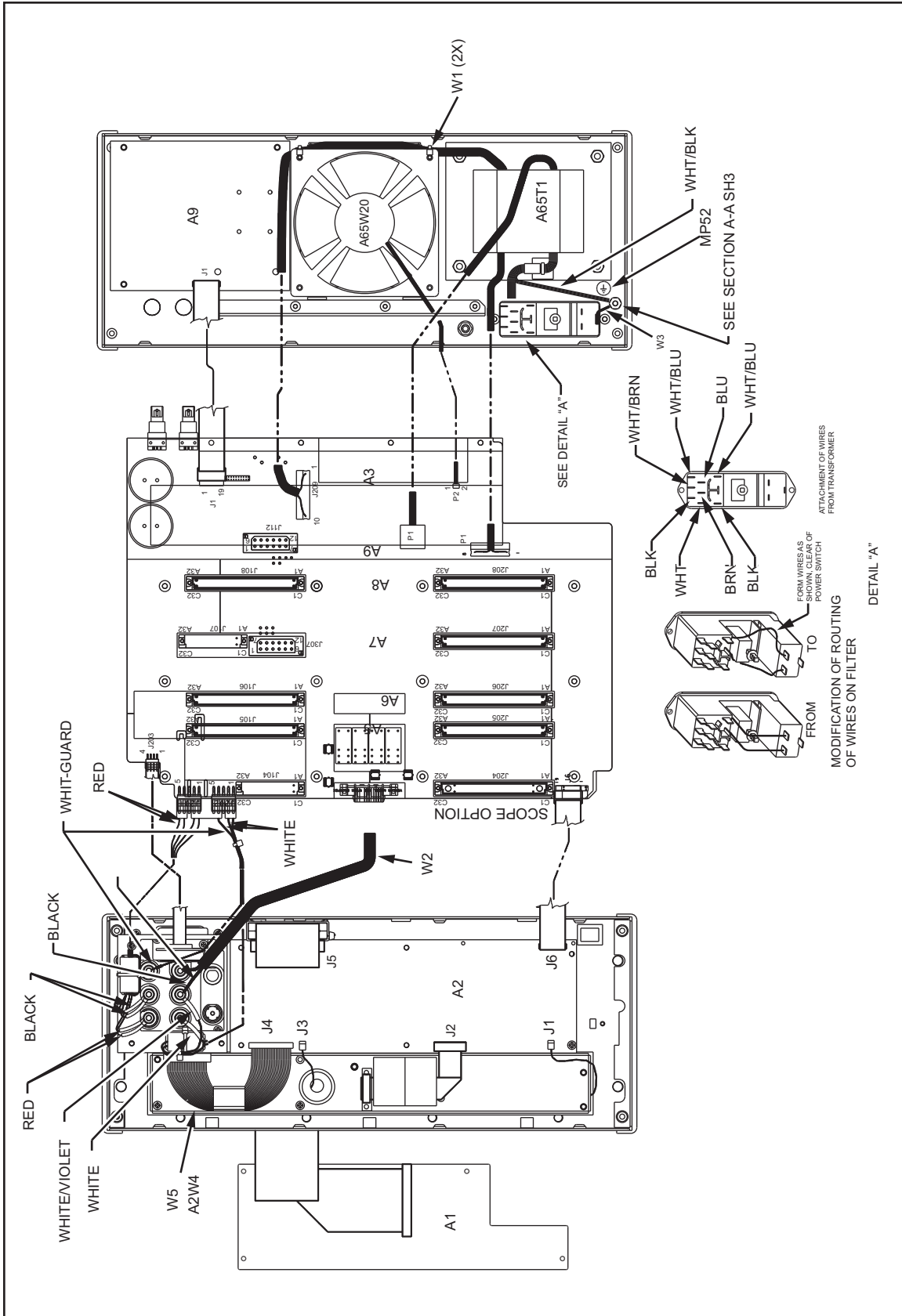

Figure 5-4. Wiring Diagram

gjh204.eps

**Table 5-5. Final Assembly**

<b>Reference Designator</b>	<b>Description</b>	<b>Fluke Part Number</b>	<b>Quantity</b>
H43-H64	SCREW, FHU, P, LOCK, MAG SS, 6-32, .250	320093	22
MP6	SHEET METAL KIT - 5522A	3834644	1
MP8	BOTTOM FOOT, MOLDED, GRAY #7	868786	4
MP10	TILT STAND	2650711	2

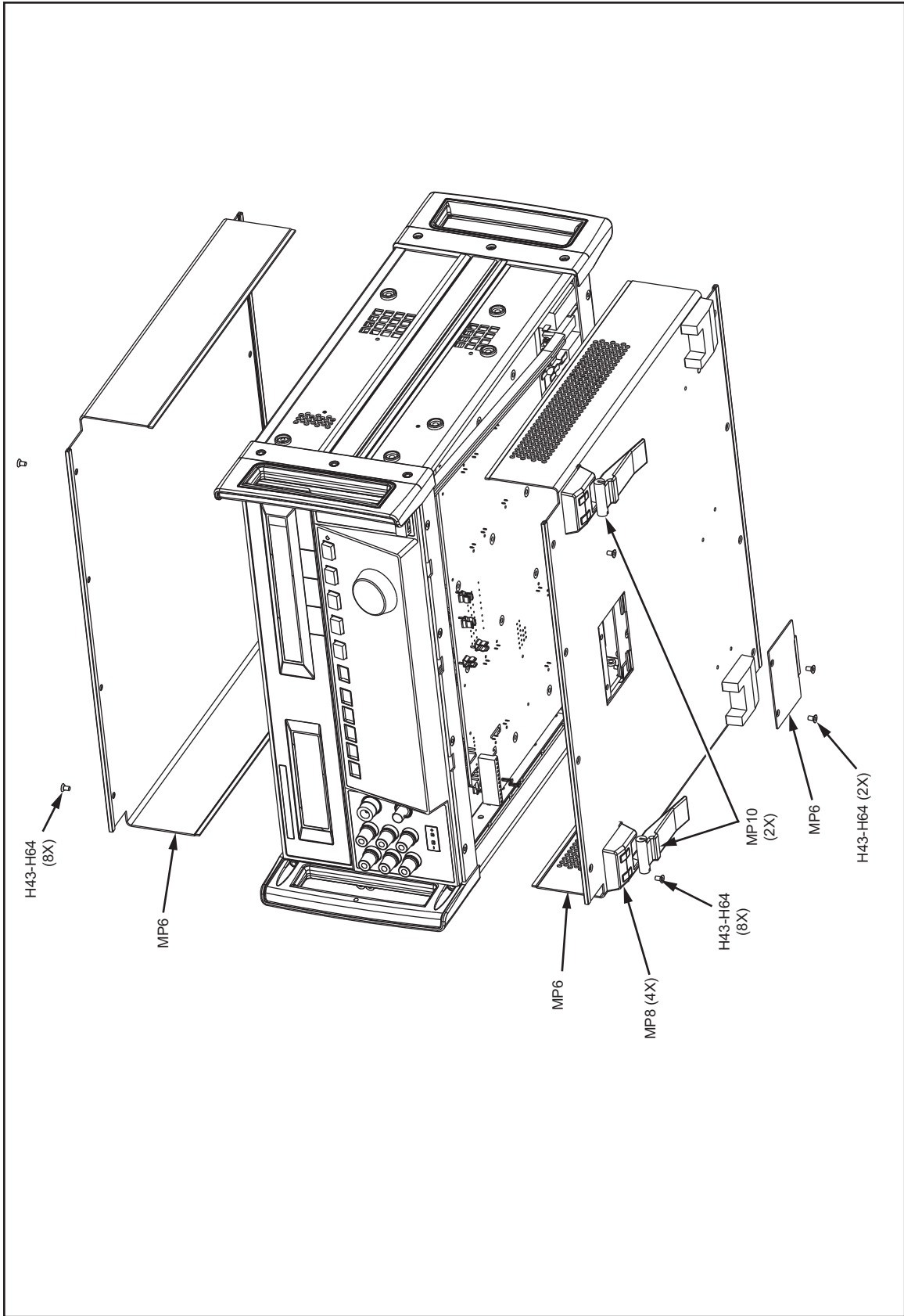

Figure 5-5. Final Assembly

gjh205.eps

# Chapter 6

## **SC600 Calibration Option**

<b>Title</b>	<b>Page</b>
Introduction.....	6-3
Maintenance.....	6-3
SC600 Specifications.....	6-3
Voltage Function Specifications.....	6-4
Edge Specifications .....	6-4
Leveled Sine Wave Specifications .....	6-5
Time Marker Specifications .....	6-5
Wave Generator Specifications .....	6-5
Pulse Generator Specifications.....	6-6
Trigger Signal Specifications (Pulse Function).....	6-6
Trigger Signal Specifications (Time Marker Function) .....	6-6
Trigger Signal Specifications (Edge Function) .....	6-6
Trigger Signal Specifications (Square Wave Voltage Function).....	6-6
Trigger Signal Specifications .....	6-6
Oscilloscope Input Resistance Measurement Specifications.....	6-6
Oscilloscope Input Capacitance Measurement Specifications .....	6-6
Overload Measurement Specifications.....	6-7
Theory of Operation.....	6-7
Voltage Mode .....	6-7
Edge Mode.....	6-7
Leveled Sine Wave Mode .....	6-7
Time Marker Mode.....	6-7
Wave Generator Mode .....	6-8
Input Impedance Mode (Resistance) .....	6-8
Input Impedance Mode (Capacitance).....	6-8
Overload Mode.....	6-8
Equipment Necessary for SC600 Calibration and Verification .....	6-10
Calibration Setup .....	6-13
Calibration and Verification of Square Wave Voltage Functions .....	6-14
Overview of HP3458A Operation .....	6-14
Voltage Square Wave Measurement Setup .....	6-14
Edge and Wave Gen Square Wave Measurements Setup .....	6-15
DC Voltage Calibration.....	6-16
AC Voltage Calibration.....	6-17
Wave Generator Calibration.....	6-17
Edge Amplitude Calibration.....	6-18
Leveled Sine Wave Amplitude Calibration.....	6-18
Leveled Sine Wave Flatness Calibration.....	6-19

Low Frequency Calibration.....	6-20
High Frequency Calibration.....	6-20
Pulse Width Calibration .....	6-21
MeasZ Calibration.....	6-22
Verification.....	6-24
DC Voltage Verification.....	6-24
Verification at 1 M $\Omega$ .....	6-25
Verification at 50 $\Omega$ .....	6-25
AC Voltage Amplitude Verification.....	6-27
Verification at 1 M $\Omega$ .....	6-28
Verification at 50 $\Omega$ .....	6-29
AC Voltage Frequency Verification.....	6-30
Edge Amplitude Verification.....	6-31
Edge Frequency Verification.....	6-32
Edge Duty Cycle Verification .....	6-33
Edge Rise Time Verification .....	6-33
Edged Aberration Verification .....	6-35
Tunnel Diode Pulser Drive Amplitude Verification.....	6-36
Leveled Sine Wave Amplitude Verification .....	6-36
Leveled Sine Wave Frequency Verification.....	6-38
Leveled Sine Wave Harmonics Verification.....	6-38
Leveled Sine Wave Flatness Verification .....	6-40
Equipment Setup for Low Frequency Flatness .....	6-41
Equipment Setup for High Frequency Flatness.....	6-41
Low Frequency Verification .....	6-42
High Frequency Verification.....	6-43
Time Marker Verification.....	6-44
Wave Generator Verification.....	6-45
Wave Generator Verification Setup .....	6-46
Verification at 1 M $\Omega$ .....	6-46
Verification at 50 $\Omega$ .....	6-47
Pulse Width Verification .....	6-49
Pulse Period Verification.....	6-50
MeasZ Resistance Verification.....	6-51
MeasZ Capacitance Verification .....	6-52
Overload Function Verification.....	6-53
SC600 Hardware Adjustments.....	6-54
Necessary Equipment .....	6-54
How to Adjust the Leveled Sine Wave Function .....	6-54
Equipment Setup .....	6-54
How to Adjust the Leveled Sine Wave VCO Balance.....	6-55
How to Adjust the Leveled Sine Wave Harmonics.....	6-55
How to Adjust the Aberrations for the Edge Function .....	6-56
Equipment Setup .....	6-56
How to Adjust the Edge Aberrations .....	6-57

## Introduction

This chapter contains information and procedures to do the servicing of the SC600 Oscilloscope Calibration Option.

The calibration and verification procedures supply traceable results for all of the SC600 functions while they are done with the recommended equipment. All of the necessary equipment, along with the minimum specifications, are shown in Table 6-1 in the “Equipment Necessary for SC600 Calibration and Verification” section.

The calibration and verification procedures in this chapter are not the ones Fluke uses at the factory. These procedures were made so you can calibrate and verify the SC600 at your own site if necessary. Look at all the procedures before you do them to make sure you have the resources to complete them. It is strongly recommended that, if possible, you send your Calibrator to Fluke for calibration and verification.

Hardware adjustments that are made after repair, at the factory, or designated Fluke service centers, are supplied in this manual.

## Maintenance

There are no maintenance procedures or diagnostic remote commands for the SC600 that are available to users. If your SC600 is not installed or is not connected to power, the error message in Figure 6-1 shows in the Calibrator display when you push **SCOPE**.

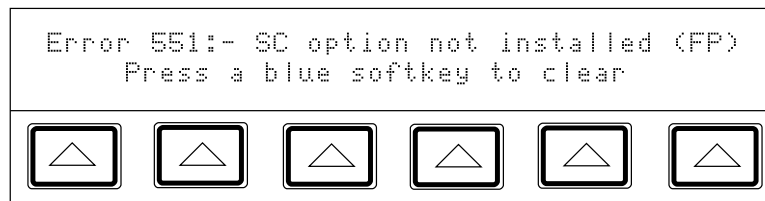

**Figure 6-1. Error Message for Scope Option**

om030i.eps

If this message shows in the display, and you have the SC600 installed in the Calibrator, you must send the Calibrator to Fluke for repair. To purchase an SC600, see your Fluke sales representative.

## SC600 Specifications

These specifications apply only to the SC600 Option. General specifications for the Calibrator mainframe can be found in Chapter 1. The specifications are correct for these conditions:

- The Calibrator is operated in the conditions specified in Chapter 1.
- The Calibrator has completed a warm-up period that is two times the period the Calibrator was turned off to a maximum of 30 minutes.
- The SC600 has been active more than 5 minutes.

### Voltage Function Specifications

Voltage Function	DC Signal		Square Wave Signal <sup>[1]</sup>	
	50 Ω Load	1 MΩ Load	50 Ω Load	1 MΩ Load
<b>Amplitude Characteristics</b>				
Range	0 to ±6.599 V	0 to ±130 V	±1 mV to ±6.599 V p-p	±1 mV to ±130 V p-p
Resolution	Range 1 to 24.999 mV 25 to 109.99 mV 110 mV to 2.1999 V 2.2 to 10.999 V 11 to 130 V		Resolution 1 μV 10 μV 100 μV 1 mV 10 mV	
Adjustment Range	Continuously adjustable			
1-Year Absolute Uncertainty, tcal ±5 °C	±(0.25 % of output + 40 μV)	± 0.05 % of output + 40 μV)	±(0.25 % of output + 40 μV)	±(0.1 % of output + 40 μV) <sup>[2]</sup>
Sequence	1-2-5 (e.g., 10 mV, 20 mV, 50 mV)			
<b>Square Wave Frequency Characteristics</b>				
Range	10 Hz to 10 kHz			
1-Year Absolute Uncertainty, tcal ±5 °C	±(2.5 ppm of setting)			
Typical aberration within 4 μs from 50 % of leading/trailing edge	<(0.5 % of output + 100 μV)			
[1] Selectable positive or negative, zero referenced square wave.				
[2] For square wave frequencies above 1 kHz, ± (0.25 % of output + 40 μV).				

### Edge Specifications

Edge Characteristics into 50 Ω Load		1-Year Absolute Uncertainty, tcal ± 5 °C
Rise Time	≤300 ps <sup>[1]</sup>	(+0 ps / -100 ps)
Amplitude Range (p-p)	4.5 mV to 2.75 V	±(2 % of output + 200 μV)
Resolution	4 digits	
Adjustment Range	±10 % around each sequence value (indicated below)	
Sequence Values	5 mV, 10 mV, 25 mV, 50 mV, 60 mV, 80 mV, 100 mV, 200 mV, 250 mV, 300 mV, 500 mV, 600 mV, 1 V, 2.5 V	
Frequency Range	900 Hz to 11 MHz	±(2.5 ppm of setting)
Typical Jitter, edge to trigger	<5 ps (p-p)	
Leading Edge Aberrations <sup>[2]</sup>	within 2 ns from 50 % of rising edge	<(3 % of output + 2 mV)
	2 to 5 ns	<(2 % of output + 2 mV)
	5 to 15 ns	<(1 % of output + 2 mV)
	after 15 ns	<(0.5 % of output + 2 mV)
Typical Duty Cycle	45 % to 55 %	
Tunnel Diode Pulse Drive	Square wave at 100 Hz to 100 kHz, with variable amplitude of 60 to 100 V p-p.	
[1] Above 2 MHz rise time specification <350 ps		
[2] All edge aberration measurements made with Tektronix 11801 mainframe with SD26 input module.		

### Leveled Sine Wave Specifications

Leveled Sine Wave Characteristics into 50 Ω	Frequency Range			
	50 kHz (reference)	50 kHz to 100 MHz	100 to 300 MHz	300 to 600 MHz
<b>Amplitude Characteristics (for measuring oscilloscope bandwidth)</b>				
Range (p-p)	5 mV to 5.5 V			
Resolution	<100 mV: 3 digits ≥100 mV: 4 digits			
Adjustment Range	continuously adjustable			
1-Year Absolute Uncertainty, tcal ±5 °C	±(2 % of output + 300 μV)	±(3.5 % of output + 300 μV)	±(4 % of output + 300 μV)	±(6 % of output + 300 μV)
Flatness (relative to 50 kHz)	not applicable	±(1.5 % of output + 100 μV)	±(2 % of output + 100 μV)	±(4 % of output + 100 μV)
Short-Term Amplitude Stability	≤ 1 % <sup>[1]</sup>			
<b>Frequency Characteristics</b>				
Resolution	1 kHz		10 kHz	
1-Year Absolute Uncertainty, tcal ±5 °C	±2.5 ppm <sup>[2]</sup>			
<b>Distortion Characteristics</b>				
2nd Harmonic	≤ -33 dBc			
3rd and Higher Harmonics	≤ -38 dBc			
<p>[1] Within 1 hour after reference amplitude setting, provided temperature varies no more than ±5 °C.</p> <p>[2] With REF CLK set to ext, the frequency uncertainty of the Leveled Sine Wave is the uncertainty of the external 10 MHz clock ±0.3 Hz/gate time.</p>				

### Time Marker Specifications

Time Maker into 50 Ω	5 s to 50 ms	20 ms to 100 ns	50 to 20 ns	10 ns	5 to 2 ns
1-Year Absolute Uncertainty at Cardinal Points, tcal ±5 °C <sup>[3]</sup>	±(25 + t * 1000) ppm <sup>[1]</sup>	±2.5 ppm	±2.5 ppm	±2.5 ppm	±2.5 ppm
Wave Shape	spike or square	spike, square, or 20 %-pulse	spike or square	square or sine	sine
Typical Output Level	>1 V p-p <sup>[2]</sup>	>1 V p-p <sup>[2]</sup>	>1 V p-p <sup>[2]</sup>	>1 V p-p <sup>[2]</sup>	>1 V p-p
Typical Jitter (rms)	<10 ppm	<1 ppm	<1 ppm	<1 ppm	<1 ppm
Sequence	5-2-1 from 5 s to 2 ns (e.g., 500 ms, 200 ms, 100 ms)				
Adjustment Range	At least ±10 % around each sequence value indicated above.				
Amplitude Resolution	4 digits				
<p>[1] t is the time in seconds.</p> <p>[2] Typical rise time of square wave and 20 %-pulse (20 % duty cycle pulse) is &lt; 1.5 ns.</p> <p>[3] Away from the cardinal points, add ±50 ppm.</p>					

### Wave Generator Specifications

Wave Generator Characteristics	Square Wave, Sine Wave, and Triangle Wave into 50 Ω or 1 MΩ
<b>Amplitude</b>	
Range	into 1 MΩ: 1.8 mV to 55 V p-p into 50 Ω: 1.8 mV to 2.5 V p-p
1-Year Absolute Uncertainty, tcal ±5 °C, 10 Hz to 10 kHz	±(3 % of p-p output + 100 μV)
Sequence	1-2-5 (e.g., 10 mV, 20 mV, 50 mV)
Typical DC Offset Range	0 to ± (≥40 % of p-p amplitude) <sup>[1]</sup>
<b>Frequency</b>	
Range	10 Hz to 100 kHz
Resolution	4 or 5 digits depending upon frequency
1-Year Absolute Uncertainty, tcal ±5 °C	±(25 ppm + 15 mHz)
[1] The DC offset plus the wave signal must not exceed 30 V rms.	

### Pulse Generator Specifications

Pulse Generator Characteristics	Positive pulse into 50 $\Omega$
Typical rise/fall times	<2 ns
Available Amplitudes	2.5 V, 1 V, 250 mV, 100 mV, 25 mV, 10 mV
<b>Pulse Width</b>	
Range	4 ns to 500 ns <sup>[1]</sup>
Uncertainty <sup>[2]</sup>	5 % of pulse width $\pm 2$ ns
<b>Pulse Period</b>	
Range	22 ms to 200 ns (45.5 Hz to 5 MHz)
Resolution	4 or 5 digits depending upon frequency and width
1-Year Absolute Uncertainty at Cardinal Points, tcal $\pm 5$ °C	$\pm 2.5$ ppm
[1] Pulse width not to exceed 40 % of period.	
[2] Pulse width uncertainties for periods below 2 $\mu$ s are not specified.	

### Trigger Signal Specifications (Pulse Function)

Pulse Period	Division Ratio	Amplitude into 50 $\Omega$ (p-p)	Typical Rise Time
22 ms to 200 ns	off/1/10/100	$\geq 1$ V	$\leq 2$ ns

### Trigger Signal Specifications (Time Marker Function)

Time Marker Period	Division Ratio	Amplitude into 50 $\Omega$ (p-p)	Typical Rise Time
2 to 9 ns	off/100	$\geq 1$ V	$\leq 2$ ns
10 to 749 ns	off/10/100	$\geq 1$ V	$\leq 2$ ns
750 ns to 34.9 ms	off/1/10/100	$\geq 1$ V	$\leq 2$ ns
35 ms to 5 s	off/1	$\geq 1$ V	$\leq 2$ ns

### Trigger Signal Specifications (Edge Function)

Edge Signal Frequency	Division Ratio	Typical Amplitude into 50 $\Omega$ (p-p)	Typical Rise Time	Typical Lead Time
900 Hz to 11 MHz	off/1	$\geq 1$ V	$\leq 2$ ns	40 ns

### Trigger Signal Specifications (Square Wave Voltage Function)

Voltage Function Frequency	Division Ratio	Typical Amplitude into 50 $\Omega$ (p-p)	Typical Rise Time	Typical Lead Time
10 Hz to 10 kHz	off/1	$\geq 1$ V	$\leq 2$ ns	1 $\mu$ s

### Trigger Signal Specifications

Trigger Signal Type	Parameters
Field Formats	Selectable NTSC, SECAM, PAL, PAL-M
Polarity	Selectable inverted or uninverted video
Amplitude into 50 $\Omega$ load	Adjustable 0 to 1.5 V p-p $\Omega$ , ( $\pm 7$ % accuracy)
Line Marker	Selectable Line Video Marker

### Oscilloscope Input Resistance Measurement Specifications

Scope Input Selected	50 $\Omega$	1 M $\Omega$
Measurement Range	40 to 60 $\Omega$	500 k $\Omega$ to 1.5 M $\Omega$
Uncertainty	0.1 %	0.1 %

### Oscilloscope Input Capacitance Measurement Specifications

Scope Input selected	1 M $\Omega$
Measurement Range	5 to 50 pF
Uncertainty	$\pm(5$ % of input + 0.5 pF) <sup>[1]</sup>
[1] Measurement made within 30 minutes of capacitance zero reference. SC600 option must be selected for at least five minutes prior to any capacitance measurement, including the zero process.	

### Overload Measurement Specifications

Source Voltage	Typical 'On' Current Indication	Typical 'Off' Current Indication	Maximum Time Limit DC or AC (1 kHz)
5 to 9 V	100 to 180 mA	10 mA	Settable 1 s to 60 s

## Theory of Operation

This section contains a brief overview of the SC600 operation modes. This information will let you identify which of the main plug-in PCAs of the Calibrator mainframe are defective. Figure 6-2 shows a block diagram of the SC600 Option (also referred to as the A50 PCA). Functions that are not shown in the figure are sourced from the DDS Assembly (A6 PCA). See Chapter 2 for a diagram of all Calibrator mainframe PCA assemblies.

### Voltage Mode

All signals for the voltage function come from the A51 Voltage/Video PCA, a daughter card to the A50 PCA. A dc reference voltage is supplied to the A51 PCA from the A6 DDS PCA. All dc and ac oscilloscope output voltages are derived from this signal and sourced on the A51 PCA. The output of the A51 PCA goes to the A50 Signal PCA (also attached to the A50 PCA) and attenuator module and is then cabled to the output connectors on the front panel. The reference dc signal is used to supply + and - dc and ac signals that are amplified or attenuated to supply the range of output signals.

### Edge Mode

The DDC A6 PCA is the source of the edge clock and goes to the A50 PCA. The signal is then shaped and divided to supply the fast edge and external trigger signals. The edge signal comes from the A50 PCA first to the attenuator assembly (where range attenuation occurs) and then to the SCOPE connector BNC on the front panel. If turned on, the trigger is connected to the Trig Out BNC on the front panel.

### Leveled Sine Wave Mode

All of the leveled sine wave signals (from 50 kHz to 600 MHz) are supplied from the A50 PCA. The leveled sine wave signal comes from the A50 PCA to the on-board attenuator assembly. The attenuator assembly supplies range attenuation and also contains a power detector which keeps amplitude flatness across the frequency range. The signal is then applied to the SCOPE connector on the front panel.

### Time Marker Mode

There are three primary “ranges” of time marker operation: 5 s to 20 ms, 10 ms to 2  $\mu$ s, and 1  $\mu$ s to 2 ns.

The A6 DDS PCA is the source of the 5 s to 20 ms markers and are sent to the A50 PCA. The signal path is also divided to supply the external trigger circuitry on the A50 PCA. If turned on, the trigger is connected to the Trig Out BNC on the front panel. The marker signal that goes through the A50 PCA is connected to the attenuator assembly. The signal is then applied to the SCOPE connector on the front panel.

The 10 ms to 2  $\mu$ s markers are derived from a square wave signal that comes from the A6 PCA and is applied to the A50 PCA for wave shaping and external trigger generation. If the trigger is turned on, the signal is connected to the Trig Out BNC on the front panel. The marker signal on the A50 PCA goes to the attenuator assembly and then to the SCOPE connector on the front panel.

The leveled sine wave generator on the A50 PCA is the source of the 1  $\mu$ s to 2 ns markers. This signal is also divided to drive the external trigger circuits. If the trigger is turned on, the signal is then connected to the Trig Out BNC on the front panel. The other path sends the signal to the marker circuits on the A50 PCA, where the signal is shaped into the other marker waveforms. The marker signals on the A50 PCA go to the attenuator assembly and then to the SCOPE connector on the front panel.

### **Wave Generator Mode**

All signals for the wavegen function come from the A6 PCA and go to the A50 PCA. They then go to the attenuator assembly, where range attenuation occurs. Wavegen signals are then sent to the SCOPE connector on the front panel. Video and pulse generator mode signals are derived from dedicated circuitry on the A50 SC600 option PCA. If there are faults related only to these functions, then the A50 PCA is most likely defective.

### **Input Impedance Mode (Resistance)**

The reference resistors for this mode are on the A50 PCA, while the DCV reference signal and measurement signals are on the A6 DDS PCA.

### **Input Impedance Mode (Capacitance)**

The A50 SC600 Scope Option PCA contains the capacitance measurement circuits, that uses signals from the leveled sine wave source. If there are faults related only to capacitance measurement, then the A50 PCA is most likely defective.

### **Overload Mode**

The A51 Voltage/Video PCA of the A50 SC600 Option PCA supplies the voltage for the overload mode. The voltage is applied to the external 50  $\Omega$  load, and the circuit current is monitored by the A6 DDS PCA.

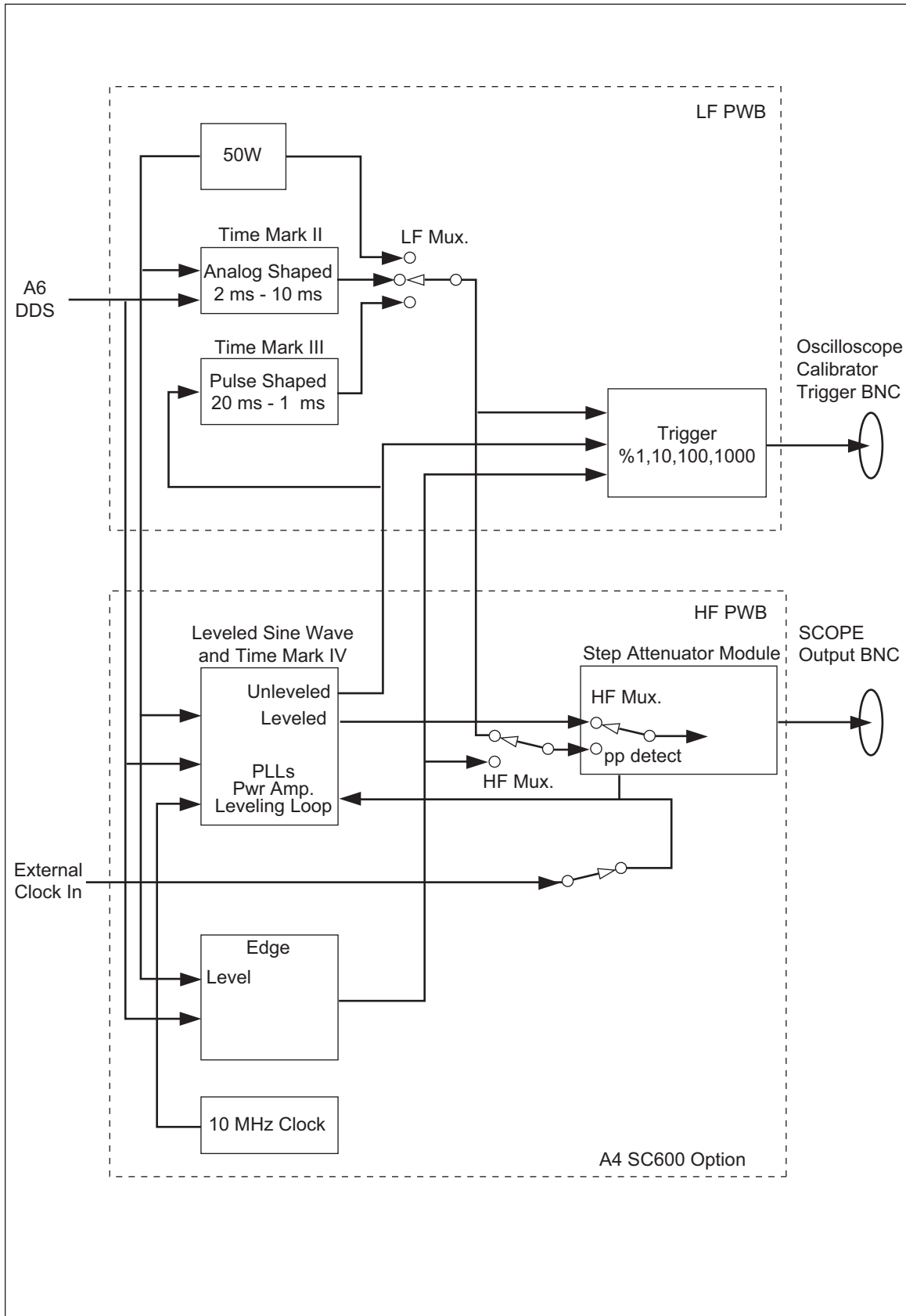

Figure 6-2. SC600 Block Diagram

om031f.eps

## Equipment Necessary for SC600 Calibration and Verification

Table 6-1 is a list of equipment necessary for calibration and verification of the SC600 Oscilloscope Option.

**Table 6-1. SC600 Calibration and Verification Equipment**

<b>Wave Generator and Edge Amplitude Calibration, AC Voltage and TD Pulsar Equipment</b>			
<b>Instrument</b>	<b>Model</b>	<b>Minimum Use Specifications</b>	
Digital Multimeter	HP 3458A	Voltage	1.8 mV to $\pm 130$ V p-p Uncertainty: 0.06 %
		Edge	4.5 mV to 2.75 V p-p Uncertainty: 0.06 %
Adapter	Pomona #1269		
Termination		Feedthrough $50 \Omega \pm 1$ % (used with edge amplitude Calibration and ac voltage verification)	
Output Cable	(supplied with SC600)	Type N to BNC	
<b>Edge Rise Time and Aberrations Verification</b>			
High-Frequency Digital Storage Oscilloscope	Tektronix 11801 with Tektronix SD-22/26 sampling head, or Tektronix TDS 820 with 8 GHz bandwidth	Frequency	12.5 GHz
		Resolution	4.5 mV to 2.75 V
Attenuator	Weinschel 9-10 (SMA) or Weinschel 18W-10 or equivalent	10 dB, 3.5 mm (m/f)	
Adapter		BNC(f) to 3.5 mm(m)	
Output Cable	(supplied with SC600)	Type N to BNC	
<b>Leveled Sine Wave Amplitude Calibration and Verification</b>			
AC Measurement Standard	Fluke 5790A	Range	5 mV p-p to 5.5 V p-p
		Frequency	50 kHz
Adapter	Pomona #1269	BNC(f) to Double Banana Plug	
Termination		Feedthrough $50 \Omega \pm 1$ %	
Output Cable	(supplied with SC600)	Type N to BNC	
<b>DC and AC Voltage Calibration and Verification, DC Voltage Verification</b>			
Digital Multimeter	HP 3458A		
Adapter	Pomona #1269	BNC(f) to Double Banana Plug	
Termination		Feedthrough $50 \Omega \pm 1$ %	
Output Cable	(supplied with SC600)	Type N to BNC	

**Table 6-1. SC600 Calibration and Verification Equipment (cont.)**

<b>Wave Generator and Edge Amplitude Calibration, AC Voltage and TD Pulser Equipment</b>			
<b>Instrument</b>	<b>Model</b>	<b>Minimum Use Specifications</b>	
<b>Pulse Width Calibration and Verification</b>			
High-Frequency Digital Storage Oscilloscope	Tektronix 11801 with Tektronix SD-22/26 sampling head		
Attenuator		3 dB, 3.5 mm (m/f)	
Adapter (2)		BNC(f) to 3.5 mm(m)	
Output Cable	(supplied with SC600)	Type N to BNC	
<b>Leveled Sine Wave Frequency Verification</b>			
Frequency Counter	PM 6680 with option (PM 9621, PM 9624, or PM 9625) and (PM 9690 or PM 9691)	50 kHz to 600 MHz, <0.15 ppm uncertainty	
Adapter	Pomona #3288	BNC(f) to Type N(m)	
Output Cable	(supplied with SC600)	Type N to BNC	
<b>Leveled Sine Wave Flatness (Low Frequency) Calibration and Verification</b>			
AC Measurement Standard	Fluke 5790A with -03 option	Range	5 mV p-p to 5.5 V p-p
		Frequency	50 kHz to 10 MHz
Adapter	Pomona #3288	BNC(f) to Type N(m)	
Output Cable	(supplied with SC600)	Type N to BNC	
<b>Leveled Sine Wave Harmonics Verification</b>			
Spectrum Analyzer	HO 8509A		
Adapter	Pomona #3288	BNC(f) to Type N(m)	
Output Cable	(supplied with SC600)	Type N to BNC	
<b>Pulse Period, Edge Frequency, AC Voltage Frequency Verification</b>			
Frequency Counter	PM 6680 with option (PM 9690 or PM 9691)	20 ms to 150 ns, 10 Hz to 10 MHz: <0.15 ppm uncertainty	
Output Cable	(supplied with SC600)	Type N to BNC	
<b>Edge Duty Cycle</b>			
Frequency Counter	PM 6680		
Output Cable	(supplied with SC600)	Type N to BNC	

Table 6-1. SC600 Calibration and Verification Equipment (cont.)

Wave Generator and Edge Amplitude Calibration, AC Voltage and TD Pulsar Equipment			
Instrument	Model	Minimum Use Specifications	
<b>Overload Functional Verification</b>			
Termination		Feedthrough 50 $\Omega$ $\pm$ 1 %	
Output Cable	(supplied with SC600)	Type N to BNC	
<b>MeasZ Resistance, Capacitance Verification</b>			
Resistors		1 M $\Omega$ and 50 $\Omega$ nominal values	
Capacitors		50 pF nominal value at the end of BNC(f) connector	
Adapters		To connect resistors and capacitors to BNC(f) connector	
Output Cable	(supplied with SC600)	Type N to BNC	
<b>Leveled Sine Wave Flatness (High Frequency) Calibration and Verification</b>			
Instrument	Model	Minimum Use Specifications	
Power Meter	Hewlett-Packard 437B	Range	-42 dBm to +5.6 dBm
		Frequency	10 MHz to 600 MHz
Power Sensor	Hewlett-Packard 8482A	Range	-20 dBm to +19 dBm
		Frequency	10 MHz to 600 MHz
Power Sensor	Hewlett-Packard 8481D	Range	-42 dBm to -20 dBm
		Frequency	10 MHz to 600 MHz
30 dB Reference Attenuator	Hewlett-Packard 11708A (supplied with HP 8481D)	Range	30 dB
		Frequency	50 MHz
Adapter	Hewlett-Packard PN 1250-1474	BNC(f) to Type N(f)	
Output Cable	(supplied with SC600)	Type N to BNC	
<b>Leveled Sine Wave Frequency, Time Marker Verification</b>			
Frequency Counter	PM 6680 with option (PM 9621, PM 9624, or PM 9625) and (PM 9690 or PM 9691)	2 ns to 5 s, 50 kHz to 600 MHz: <0.15 ppm uncertainty	
Adapter	Pomona #3288	BNC(f) to Type N(m)	
Output Cable	(supplied with SC600)	Type N to BNC	

Table 6-1. SC600 Calibration and Verification Equipment (cont.)

Wave Generator and Edge Amplitude Calibration, AC Voltage and TD Pulsar Equipment			
Instrument	Model	Minimum Use Specifications	
<b>Wave Generator Verification</b>			
AC Measurement Standard	Fluke 5790A with -03 option	Range	1.8 mV p-p to 55 V p-p
		Frequency	10 Hz to 100 kHz
Adapter	Pomona #1269	BNC(f) to Double Banana Plug	
Termination		Feedthrough 50 Ω ±1 %	
Output Cable	(supplied with SC600)	Type N to BNC	

## Calibration Setup

The procedures in this manual were made to let users calibrate the SC600 at their own site if it becomes necessary to do so. It is strongly recommended that, if possible, you send your Calibrator to Fluke for calibration and verification. The Calibrator Mainframe must be fully calibrated before you do calibration of the SC600.

The hardware adjustments are intended to be one-time adjustments done in the factory. Adjustment can be necessary after repair. Hardware adjustments must be done before calibration. Calibration must be done after if hardware adjustments are made. See the “Hardware Adjustments” section in this chapter.

The AC Voltage function is dependent on the DC Voltage function. Calibration of the AC Voltage function is necessary after the DC Voltage is calibrated.

The Calibrator Mainframe must complete a warm-up period and the SC600 must be turned on for a minimum of 5 minutes before you start calibration. This lets internal components become thermally stable. The Calibrator Mainframe warm-up period is a minimum of two times the period the calibrator was turned off, or a maximum of 30 minutes. Push **SCOPE** to turn on the SC600. The green LED on the SCOPE key is illuminated when the SC600 is turned on.

Most of the SC600 Option can be calibrated from the front panel. Push **SCOPE** to turn on the SC600 and wait a minimum of 5 minutes. To start the Scope Cal mode:

1. Push **SETUP**.
2. Push the **CAL** softkey.
3. Push the **CAL** softkey again.
4. Push the **SCOPE CAL** softkey.

### Note

*If you push the **Scope Cal** softkey sooner than 5 minutes after you pushed **SCOPE**, a warning message shows in the display.*

All equipment used to calibrate the SC600 must be calibrated, certified traceable if traceability is to be kept, and operated in their specified operation environment.

It is also important to make sure that the equipment has had sufficient time to warm up before you start calibration. Refer to the operation manual for each piece of equipment for more information.

Before you start calibration, look at all of the procedures to make sure you have the resources to do them.

The Calibrator starts calibration with the DC Voltage function. If it is necessary to start with a different function, push the **OPTIONS** softkey. Then push the **NEXT SECTION** softkey until you see the function name in the display.

## Calibration and Verification of Square Wave Voltage Functions

The Voltage, Edge, and Wave Generator functions have square wave voltages that must be calibrated or verified. The HP3458A digital multimeter can be programmed from the front panel or through the remote interface to make these measurements.

### Overview of HP3458A Operation

The Hewlett-Packard 3458A digital multimeter is configured as a digitizer to measure the peak-to-peak value of the signal. It is set to DCV, with different analog-to-digital integration times and trigger commands to measure the topline and baseline of the square wave signal.

### Voltage Square Wave Measurement Setup

To make accurate and repeatable measurements of the topline and baseline of a voltage square wave with a maximum frequency of 10 kHz, set the integration and sample time of the HP3458A. For this measurement, connect the external trigger of the HP3458A to the external trigger output of the SC600. Set the HP3458A to make an analog-to-digital conversion after it senses the falling edge of an external trigger.

The conversion does not occur until after the delay set by the 3458A “DELAY” command. The frequency measured by the DMM influences the actual integration time. Table 6-2 summarizes the DMM settings necessary to make topline and baseline measurements. Figure 6-3 illustrates the correct connections for this setup.

Table 6-2. Voltage HP3458A Settings

Voltage Input Frequency	HP3458A Settings		
	NPLC	DELAY (topline)	DELAY (baseline)
100 Hz	0.1	0.007 s	0.012 s
1 kHz	0.01	0.0007 s	0.0012 s
5 kHz	0.002	0.00014	0.00024
10 kHz	0.001	0.00007	0.00012

For all measurements, the HP 3458A is in DCV, manual range, with external trigger turned on. A convenient method to make these measurements from the front panel of the HP3458A is to put these parameters into some of the user-defined keys. For example, to make topline measurements at 1 kHz, you set the DMM to “NPLC .01; DELAY .0007; TRIG EXT”. To find the average of multiple measurements, you can set one of the keys to “MATH OFF; MATH STAT” and then use the “RMATH MEAN” function to recall the average or mean value.

#### Note

*For this application, if you make measurements of a signal >1 kHz, the HP 3458A can show 0.05 % to 0.1 % peaking in the 100 mV range. For these signals, lock the HP 3458A to the 1 V range.*

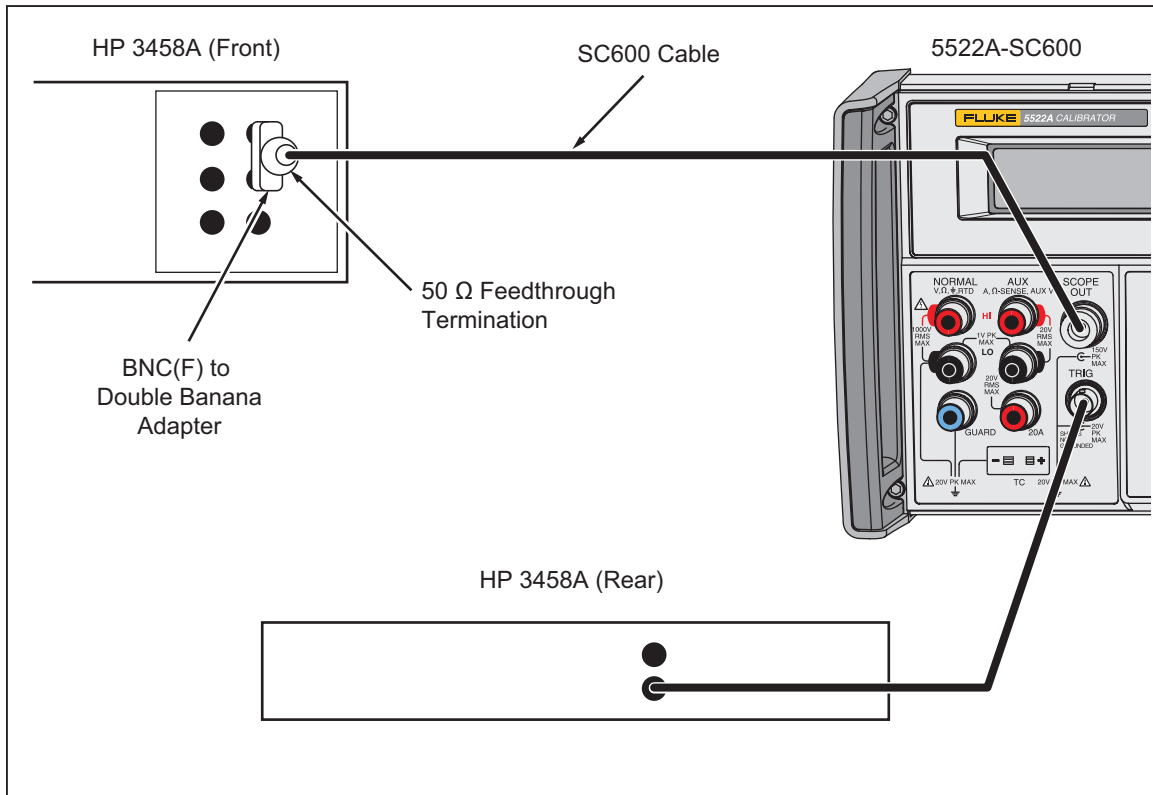

Figure 6-3. Equipment Setup for SC600 Voltage Square Wave Measurements

gjh105.eps

### Edge and Wave Gen Square Wave Measurements Setup

The setup to measure the topline and baseline of Edge and Wave Generator signals is a little different from the Voltage Square Wave method given above. The HP 3458A is triggered by a change in input level rather than an external trigger. The trigger level is set to 1 % of the DCV range, with ac coupling of the trigger signal. The delay after the trigger event is also changed for the Edge and Wave Generator functions. See Table 6-3 and Figure 6-4.

Table 6-3. Edge and Wave Generator HP 3458A Settings

Voltage Input Frequency	HP3458A Settings		
	NPLC	DELAY (topline)	DELAY (baseline)
1 kHz	.01	.0002 s	.0007 s
10 kHz	.001	.00002 s	.00007 s



HP 3458A DC voltage measurement become stable. Type in the measurement through the Calibrator keypad and then push .

*Note*

*The Calibrator will show a message if the typed in value is higher or lower than the limits of the value. If this occurs, examine the setup and carefully re-type in the measurement with the correct multiplier (i.e., m,  $\mu$ , n, p). If the warning continues, repair may be necessary.*

7. Do step 6 again until the Calibrator shows that the subsequent steps calibrate ac voltage. Push the **OPTIONS**, then **STORE CONSTS** softkeys to store the new calibration constants.

AC voltage must be calibrated: continue with the subsequent section.

### **AC Voltage Calibration**

This procedure uses the same equipment and setup as DC Voltage calibration. Refer to Figure 6-4. DC voltages are measured and typed in to the Calibrator to calibrate the AC Voltage function.

To calibrate the Calibrator for ac voltage:

1. Push the **OPTIONS** softkey.
2. Push the **NEXT SECTION** softkey until “The next steps calibrate -SC600 ACV” shows in the display.
3. Push the **GO ON** softkey.
4. Let the HP 3485A voltage measurement become stable.
5. Type in the measurement through the keypad of the Calibrator.
6. Push .

*Note*

*The Calibrator will show a message if the typed in value is higher or lower than the limits of the value. If this occurs, examine the setup and carefully re-type in the measurement with the correct multiplier (i.e., m,  $\mu$ , n, p). If the warning continues, repair may be necessary.*

7. Do step 4 again until the Calibrator shows that the subsequent steps calibrate WAVGEN. Push the **OPTIONS**, then **STORE CONSTS** softkeys to store the new calibration constants.

### **Wave Generator Calibration**

This procedure uses:

- Hewlett-Packard 3458A Digital Multimeter
- BNC(f) to Double Banana adapter
- Output cable supplied with the SC600

To calibrate the wave generator:

1. Push the **OPTIONS** softkey.
2. Push the **NEXT SECTION** softkey until “WAVEGEN Cal:” shows in the display.
3. Connect the SCOPE connector of the Calibrator to the HP3458A input with the output cable and the BNC(f) to Double Banana adapter.
4. Set the HP 3458A to DCV, NPLC = .01, LEVEL 1, TRIG LEVEL.

5. Set the HP 3458A DELAY to .0002 for the top part of the waveform (i.e. topline) measurement, and .0007 for the lower part of the waveform (i.e. baseline). Manually range lock the HP 3458A to the range that gives the most resolution for the topline measurements. Use this same range for the related baseline measurements at each step.
6. For each calibration step, get samples for 2 seconds minimum, with the HP 3458A MATH functions to retrieve the average or mean value. See the “Setup for SC600 Edge and Wave Generator Measurements” section for more information.

### Edge Amplitude Calibration

This procedure uses:

- Hewlett-Packard 3458A Digital Multimeter
- BNC(f) to Double Banana adapter
- Output cable supplied with the SC600
- 50  $\Omega$  feedthrough termination

To do Edge Amplitude Calibration:

1. Setup the equipment as shown in Figure 6-4.
2. Push the **OPTIONS** softkey.
3. Push the **NEXT SECTION** softkey until “Set up to measure fast edge amplitude” shows in the display.
4. Connect the SCOPE connector of the Calibrator to the HP 3458A input with the output cable and the BNC(f) to Double Banana adapter.
5. Set the HP 3458A to DCV, NPLC = .01, LEVEL 1, TRIG LEVEL.
6. Set the HP 3458A DELAY to .0002 for the top part of the waveform (or topline) measurement, and .0007 for the lower part of the waveform (or baseline). Manually range lock the HP 3458A to the range that gives the most resolution for the baseline measurements. Use this same range for the related baseline measurements at each step.

#### Note

*For the edge function, the topline is near 0 V and the baseline is a negative voltage.*

7. For each calibration step, get samples for 2 seconds minimum, with the HP 3458A MATH functions to retrieve the average or mean value. See the “Setup for SC600 Edge and Wave Generator Measurements” section for more information.

The “true amplitude” of the waveform is the difference between the topline and baseline measurements, after a load resistance error correction. To make this correction, multiply the measurement by  $(0.5 * (50 + Rload)/Rload)$ , where Rload = actual feedthrough termination resistance.

### Leveled Sine Wave Amplitude Calibration

This procedure uses:

- 5790A AC Measurement Standard
- BNC(f) to Double Banana adapter
- Output cable supplied with the SC600
- 50  $\Omega$  feedthrough termination

To do a leveled sine wave amplitude calibration:

1. Push the **OPTIONS** softkey.
2. Push the **NEXT SECTION** softkey until “Set up to measure fast edge amplitude” shows in the display.
3. Connect the output cable to the 50 Ω feedthrough termination.
4. Connect the other end of the output cable to the SCOPE connector of the Calibrator.
5. Connect the 50 Ω feedthrough termination at the other end of the cable to input 2 of the 5790A with the BNC(f) to Double Banana adapter.
6. Set the 5790A to AUTORANGE, digital filter mode to FAST, restart fine, and Hi Res on.
7. Push the **GO ON** softkey on the Calibrator.
8. Push **OPR** to turn on the Calibrator output.
9. Let the 5790A rms measurement become stable.
10. Multiply the 5790A measurement by  $(0.5 * (50 + R_{load})/R_{load})$ , where  $R_{load}$  = the actual feedthrough termination resistance, to correct for the resistance error. Type in the corrected rms measurement through the keypad of the Calibrator.
11. Push **ENTER**.

*Note*

*The Calibrator will show a message if the typed in value is higher or lower than the limits of the value. If this occurs, examine the setup and carefully re-type in the measurement with the correct multiplier (i.e., m, μ, n, p). If the warning continues, repair may be necessary.*

12. Do step 10 and 11 again until the Calibrator shows that the subsequent steps calibrate Leveled Sine flatness. Push the **OPTIONS**, then **STORE CONSTS** softkeys to store the new calibration constants.

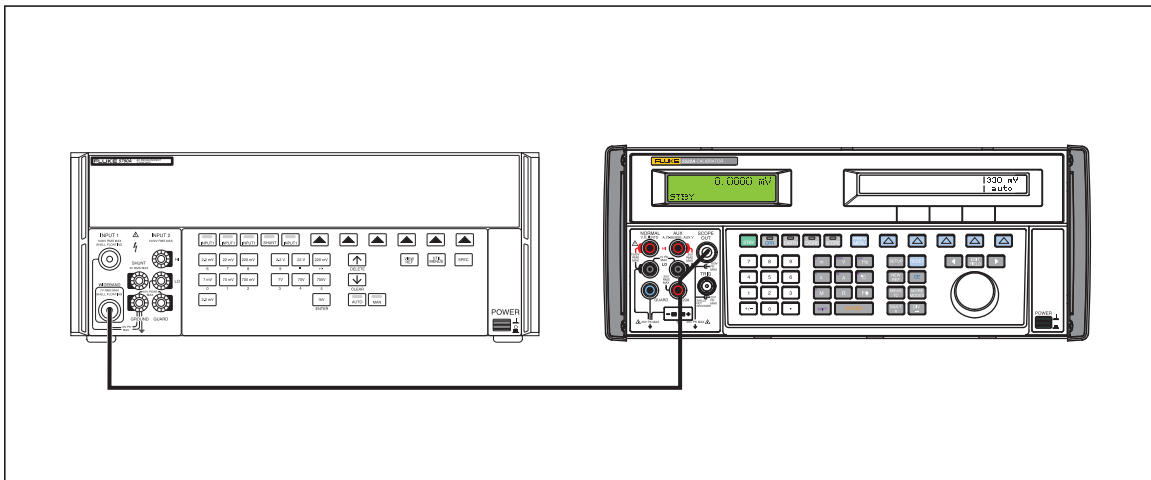

**Figure 6-5. Calibrator to 5790A AC Measurement Standard Connections**

gjh103.eps

**Leveled Sine Wave Flatness Calibration**

Leveled Sine Wave flatness calibration is divided into two frequency bands: 50 kHz to 10 MHz (low frequency) and >10 MHz to 600 MHz (high frequency). The equipment setups are different for each band. Flatness calibration of the low frequency band is made

relative to 50 kHz. Flatness calibration of the high frequency band is made relative to 10 MHz.

Leveled Sine Wave flatness is calibrated at multiple amplitudes. The low and high frequency bands are calibrated at each amplitude. Calibration starts with the low frequency band, then the high frequency band for the first amplitude, followed by the low frequency band, then the high frequency band for the second amplitude, and so on, until the flatness calibration is complete.

Push the **OPTIONS** and **NEXT SECTION** softkeys until “Set up to measure leveled sine flatness” shows in the display.

### *Low Frequency Calibration*

To do the low frequency calibration:

1. Connect the SCOPE connector of the Calibrator to the wideband input of the 5790A. See the “Equipment Setup for Low Frequency Flatness” section for more information.
2. Push the **GO ON** softkey.
3. Find the 50 kHz reference.
  - Let the 5790A measurement become stable.
  - Push the 5790A **Set Ref** softkey.
4. Push the 5790A **Clear Ref** softkey to clear the reference if necessary.
5. Push the **GO ON** softkey.
6. Adjust the amplitude with the front panel knob of the Calibrator until the 5790A reference deviation equals the 50 kHz reference  $\pm 1000$  ppm.
7. Do steps 2 through 6 again until Calibrator shows that the reference frequency is 10 MHz.

Continue with the high frequency calibration.

### *High Frequency Calibration*

To do the high frequency calibration:

1. Connect the SCOPE connector of the Calibrator to the power meter and power sensor. See the “Equipment Setup for High Frequency Flatness” section for more information.
2. Push the **GO ON** softkey.
3. Find the 10 MHz reference.
  - Push the power meter **SHIFT Key**, then **FREQ** key and use the arrow keys to type in the cal factor of the power sensor. Make sure the factor is correct, then push the **ENTER** key on the power meter.
  - Let the power meter measurement become stable.
  - Push the power meter **REL** key.
4. Push the **GO ON** softkey.
5. Push the power meter **SHIFT key**, then **FREQ** key, and use the arrow keys to set the Cal Factor of the power sensor for the frequency shown in the Calibrator display. Make sure that the factor is correct, then push the power meter **ENTER** key.
6. Adjust the amplitude with the front panel knob of the Calibrator until the power sensor is equal to the 10 MHz reference  $\pm 0.1$  %.

7. Do steps 1 through 5 again until the Calibrator display shows that the reference frequency is now 50 kHz or that the subsequent step is calibrate pulse width.

Do the low frequency calibration procedure for the subsequent amplitude unless the Calibrator Mainframe display shows that the subsequent steps calibrate pulse width. Push the **OPTIONS**, then **STORE CONSTS** softkeys to store the new calibration constants.

### **Pulse Width Calibration**

This procedure uses:

- High Frequency Digital Storage Oscilloscope (DSO): Tektronix 11801 with Tektronix SD-22/26 sampling head
- 3 dB attenuator, 3.5 mm (m/f)
- BNC(f) to 3.5 mm(m) adapter (2)
- Output cable supplied with the SC600
- Second BNC cable

To do a pulse width calibration:

1. Push the **OPTIONS** softkey.
2. Push the **NEXT SECTION** softkey until “Set up to measure pulse width” shows in the display.
3. Connect the output cable to the SCOPE connector on the Calibrator. Connect the other end of the output cable to one of the BNC(f) to 3.5 mm (m) adapter and then to the sampling head of the DSO through the 3 dB attenuator.
4. Use the second BNC cable with the BNC(f) to 3.5 mm(m) adapter attached to connect the TRIG OUT of the Calibrator to the trigger input of the DSO.
5. Set the DSO to:
  - Main Time Base: 40 ns
  - Vertical scale: 200 mV/div, +900 mV offset
  - Trigger: source = ext, level = 0.5 V, ext.  
atten. = x10, slope = +, mode = auto
  - Measurement function: positive width
6. Push the **GO ON** softkey.
7. Adjust the DSO horizontal scale and main time base position until the pulse signal spans between half and full display. If no pulse is output, increase the pulse width with the front-panel knob of the Calibrator until a pulse is output.
8. If instructed to adjust the pulse width by the Calibrator display, adjust the pulse width to as near 4 ns as possible with the front-panel knob of the Calibrator.
9. Push the **GO ON** softkey.
10. Let the DSO width measurement become stable.
11. Type in the measurement through the keypad of the Calibrator.
12. Push .

*Note*

*The Calibrator shows a message if the typed in value is higher or lower than the limits of the value. If this occurs, examine the setup and carefully re-type in the measurement with the correct multiplier ( $m$ ,  $\mu$ ,  $n$ ,  $p$ ). If the warning continues, type in a value between the pulse width shown in the display and the last typed in value. Continue to do this with a value that is nearer to the pulse width in the display until the value is accepted. After you complete the pulse width calibration you must re do the calibration until all typed in values are accepted the first time without the message.*

13. Do steps 7 through 12 again until the Calibrator instructs you to connect a resistor.
14. Push the **OPTIONS**, then **STORE CONSTS** softkeys to store the new calibration constants.

### **MeasZ Calibration**

The MeasZ function is calibrated with resistors and a capacitor of known values. The actual resistance and capacitance values are typed in while they are measured by the Calibrator.

The resistors and capacitor must make a solid connection to a BNC(f) to make a connection to the end of the output cable supplied with the SC600. The resistance and capacitance values must be known at this BNC(f) connector. An HP 3458A DMM is used to make a 4-wire ohms measurement at the BNC(f) connector to find the actual resistance values. An HP 4192A Impedance Analyzer at 10 MHz is used to find the actual capacitance value.

This procedure uses:

- Resistors of known values: 1 M $\Omega$  and 50  $\Omega$  nominal
- Adapters to connect resistors to the BNC(f) connector
- Adapters and capacitor to get 50 pF nominal value at the end of the BNC(f) connector
- Output cable supplied with the SC600

To do a MeasZ calibration:

1. Connect the equipment as shown in Figure 6-6.

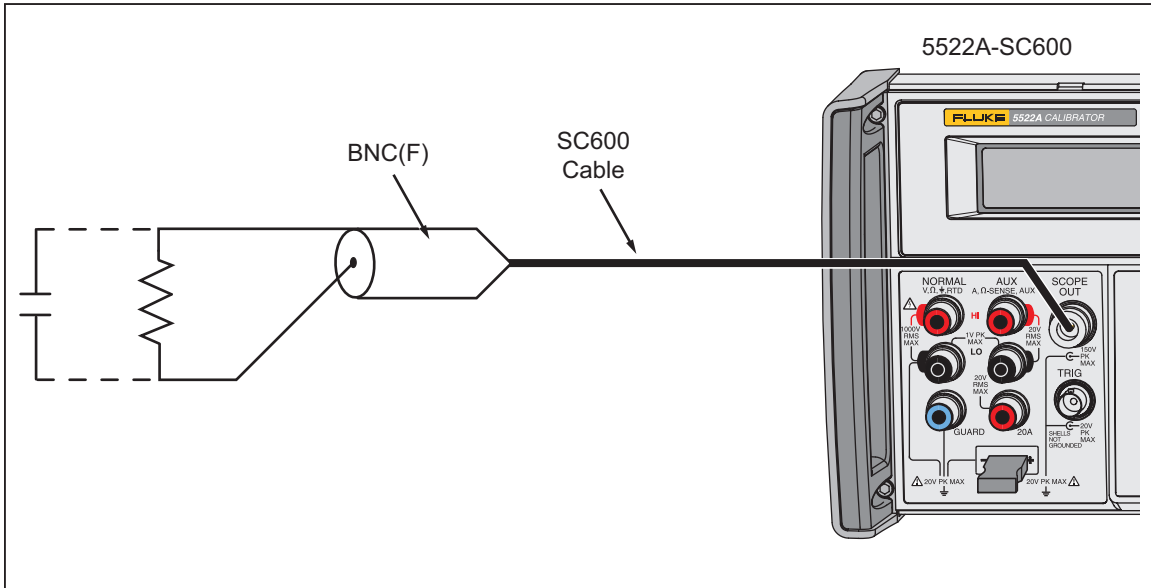

**Figure 6-6. MeasZ Calibration Connections**

gjh107.eps

2. Push the **OPTIONS** softkey.
3. Push the **NEXT SECTION** softkey until “connect a 50  $\Omega$  resistor” shows in the display.
4. Connect the output cable to the SCOPE connector of the Calibrator.
5. Connect the other end of the output cable to BNC(f) connector attached to the 50  $\Omega$  resistor.
6. Push the **GO ON** softkey.
7. Type in the 50  $\Omega$  resistance.

*Note*

*The Calibrator will show a message if the typed in value is higher or lower than the limits of the value. If this occurs, examine the setup and carefully re-type in the measurement with the correct multiplier (m,  $\mu$ , n, p). If the warning continues, repair may be necessary.*

8. When instructed by the Calibrator, disconnect the 50  $\Omega$  resistance and connect the 1 M $\Omega$  resistance to the end of the output cable.
9. Push the **GO ON** softkey.
10. Type in the actual 1 M $\Omega$  resistance.
11. When instructed for the first reference capacitor by the Calibrator, disconnect the 1 M $\Omega$  resistance and leave nothing attached to the end of the output cable.
12. Push the **GO ON** softkey.
13. Enter 0.
14. When prompted for the second reference capacitor by the Calibrator, connect the 50 pF capacitance to the end of the output cable.
15. Push the **GO ON** blue softkey.
16. Type in the actual 50 pF capacitance.
17. When the Calibrator shows calibration is complete in the display, push the **OPTIONS**, then **STORE CONSTS** softkeys to store the new calibration constants.

## Verification

Do a verification of all Oscilloscope Calibration functions a minimum of one time each year, or when the SC600 is calibrated. The verification procedures in this section supply traceable results. The factory uses different procedures and instruments of higher precision than those shown in this manual. The procedures in this manual let you verify the SC600 at your site if necessary. Fluke recommends you send the Calibrator to Fluke for calibration and verification.

All equipment used to do a verification on the SC600 must be calibrated, certified traceable if traceability is to be kept, and operated in their specified operation environment.

It is also important to make sure that the equipment has had sufficient time to warm up before you start verification. Refer to the operation manual for each piece of equipment for more information.

Before you start verification, look at all of the procedures to make sure you have the resources to do them.

Table 6-4 is a list of the SC600 functions and verification methods.

**Table 6-4. Verification Methods for SC600 Functions**

Function	Verification Method
DC Voltage	Procedure supplied in this manual.
AC Voltage amplitude	Procedure supplied in this manual.
AC Voltage frequency	Procedure supplied in this manual.
Edge amplitude	Procedure supplied in this manual.
Edge frequency, duty cycle, rise time	Procedure supplied in this manual.
Tunnel Diode Pulser amplitude	Procedure supplied in this manual. See the "Voltage and Edge Calibration and Verification" section for more information.
Leveled sine wave amplitude, frequency, harmonics, and flatness	Procedure supplied in this manual.
Time marker period	Procedure supplied in this manual.
Wave generator amplitude	Procedure supplied in this manual.
Pulse width, period	Procedure supplied in this manual.
MeasZ resistance, capacitance	Procedure supplied in this manual.
Overload functionality	Procedure supplied in this manual.

### DC Voltage Verification

This procedure uses:

- Hewlett-Packard 3458A Digital Multimeter
- BNC(f) to Double Banana adapter
- Output cable supplied with the SC600
- 50  $\Omega$  feedthrough termination

For dc voltage verification, see Figure 6-4 for equipment connections.

Set the Calibrator to SCOPE mode, with the Volt menu shown in the display.

**Verification at 1 MΩ**

To do a 1 MΩ verification:

1. Connect the SCOPE connector of the Calibrator to the HP 3458A input, with the cable and the BNC(f) to Double Banana adapter.
2. Make sure the Calibrator is set to 1 MΩ (The **Output @** softkey toggles the impedance between 50 Ω and 1 MΩ).
3. Set the HP 3458A to DCV, Auto Range, NPLC = 10, FIXEDZ = on.
4. Set the Calibrator output to the voltage in Table 6-5.
5. Push **OPR** on the Calibrator.
6. Let the HP 3458A measurement become stable.
7. Record the HP 3458A measurement for each voltage in Table 6-5.
8. Compare the result to the tolerance column.

**Verification at 50 Ω**

To do a 50 Ω verification:

1. Connect the SCOPE connector of the Calibrator to the HP 3458A input, with the cable and the 50 Ω termination connected to the BNC(f) to Double Banana adapter.
2. Make sure the Calibrator impedance is set to 50 Ω (The **Output @** softkey toggles the impedance between 50 Ω and 1 MΩ).
3. Set the HP 3458A to DCV, Auto Range, NPLC = 10, FIXEDZ = on.
4. Set the Calibrator output to the voltage in Table 6-6.
5. Push **OPR** on the Calibrator.
6. Let the HP 3458A measurement become stable.
7. Record the HP 3458A measurement for each voltage in Table 6-6.
8. Compare the result to the tolerance column.

**Table 6-5. DC Voltage Verification at 1 MΩ**

Calibrator Output	HP3458A Measurement (V dc)	Tolerance ±(V dc)
0 mV		0.00004 V
1.25 mV		4.063E-05 V
-1.25 mV		4.063E-05 V
2.49 mV		4.125E-05 V
-2.49 mV		4.125E-05 V
2.5 mV		4.125E-05 V
-2.5 mV		4.125E-05 V
6.25 mV		4.313E-05 V
-6.25 mV		4.313E-05 V
9.90 mV		4.495E-05 V

Table 6-5. DC Voltage Verification at 1 M $\Omega$  (cont.)

Calibrator Output	HP3458A Measurement (V dc)	Tolerance $\pm$ (V dc)
-9.90 mV		4.495E-05 V
10.0 mV		0.000045 V
-10.0 mV		0.000045 V
17.5 mV		4.875E-05 V
-17.5 mV		4.875E-05 V
24.9 mV		5.245E-05 V
-24.9 mV		5.245E-05 V
25.0 mV		0.0000525 V
-25.0 mV		0.0000525 V
67.5 mV		7.375E-05 V
-67.5 mV		7.375E-05 V
109.9 mV		9.495E-05 V
-109.9 mV		9.495E-05 V
110 mV		0.000095 V
-110 mV		0.000095 V
305 mV		0.0001925 V
-305 mV		0.0001925 V
499 mV		0.0002895 V
-499 mV		0.0002895 V
0.50 V		0.00029 V
-0.50 V		0.00029 V
1.35 V		0.000715 V
-1.35 V		0.000715 V
2.19 V		0.001135 V
-2.19 V		0.001135 V
2.20 V		0.00114 V
-2.20 V		0.00114 V
6.60 V		0.00334 V
-6.60 V		0.00334 V
10.99 V		0.005535 V
-10.99 V		0.005535 V
11.0 V		0.00554 V
-11.0 V		0.00554 V

**Table 6-5. DC Voltage Verification at 1 MΩ (cont.)**

Calibrator Output	HP3458A Measurement (V dc)	Tolerance ±(V dc)
70.5 V		0.03529 V
-70.5 V		0.03529 V
130.0 V		0.06504 V
-130.0 V		0.06504 V

**Table 6-6. DC Voltage Verification at 50 Ω**

Calibrator Output	HP3458A Measurement (V dc)	Tolerance (V dc min.)	Tolerance (V dc max.)
0 mV		-0.040 mV	0.040 mV
2.49 mV		2.4438 mV	2.5362 mV
-2.49 mV		-2.5362 mV	-2.4438 mV
9.90 mV		9.835 mV	9.965 mV
-9.90 mV		-9.965 mV	-9.835 mV
24.9 mV		24.798 mV	25.002 mV
-24.9 mV		-25.002 mV	-24.798 mV
109.9 mV		109.585 mV	110.215 mV
-109.9 mV		-110.215 mV	-109.585 mV
499 mV		497.71 mV	500.29 mV
-499 mV		-500.29 mV	-497.71 mV
2.19 V		2.1845 V	2.1955 V
-2.19 V		-2.1955 V	-2.1845 V
6.599 V		6.5825 V	6.6155 V
-6.599 V		-6.6155 V	-6.5825 V

**AC Voltage Amplitude Verification**

This procedure uses:

- Hewlett-Packard 3458A Digital Multimeter
- BNC(f) to Double Banana adapter
- Output cable supplied with the SC600
- 50 Ω feedthrough termination
- Second BNC cable

For ac voltage verification, see Figure 6-3 for equipment connections.

Set the Calibrator to SCOPE mode, with the Volt menu shown in the display.

### Verification at 1 M $\Omega$

To do a 1 M $\Omega$  verification:

1. Connect the SCOPE connector of the Calibrator to the HP 3458A input, with the cable and the BNC(f) to Double Banana adapter.
2. Connect the TRIG OUT connector of the Calibrator to the EXT Trig connector on the rear panel of the HP3458A.
3. Make sure the Calibrator is set to 1 M $\Omega$  (The **Output @** softkey toggles the impedance between 50  $\Omega$  and 1 M $\Omega$ ).
4. For ac voltage output at 1 kHz, set the HP 3458A to DCV, NPLC = .01, TRIG EXT.
5. Set the HP 3458A DELAY to .0007 for the top part of the waveform (or topline) measurement, and .0012 for the lower part of the waveform (or baseline). Manually range lock the HP 3458A to the range that gives the most resolution for the topline measurements. Use this same range for the related baseline measurements at each step.
6. Push the TRIG softkey on the Calibrator until **/1** shows in the display.
7. Measure the topline first as shown in Table 6-7. For each measurement, get samples for 2 seconds minimum, with the HP 3458A MATH functions to retrieve the average or mean value. See the “Setup for SC600 Edge and Wave Generator Measurements” section for more information.
8. Measure the baseline of each output after the topline measurement, as shown in Table 6-7. The peak-to-peak value is the difference between the topline and baseline measurements. Compare the result to the tolerance column.
9. When you make measurements at the other frequencies, set up the HP 3458A (NPLC and topline and baseline DELAY) as shown in Table 6-2. (See the “Setup for SC600 Voltage Square Wave Measurements” section.)

**Table 6-7. AC Voltage Verification at 1 M $\Omega$**

Calibrator Output (1 kHz, or as noted)	HP3458A Range	Topline Measurement	Baseline Measurement	Peak-to-Peak	Tolerance ( $\pm$ V)
1 mV	100 mV dc				0.000041
-1 mV	100 mV dc				0.000041
10 mV	100 mV dc				0.00005
-10 mV	100 mV dc				0.00005
25 mV	100 mV dc				0.000065
-25 mV	100 mV dc				0.000065
110 mV	100 mV dc				0.00015
-110 mV	100 mV dc				0.00015
500 mV	1 V dc				0.00054
-500 mV	1 V dc				0.00054
2.2 V	10 V dc				0.00224
-2.2 V	10 V dc				0.00224

Table 6-7. AC Voltage Verification at 1 MΩ (cont.)

Calibrator Output (1 kHz, or as noted)	HP3458A Range	Topline Measurement	Baseline Measurement	Peak-to-Peak	Tolerance (±V)
11 V	10 V dc				0.01104
-11 V	10 V dc				0.01104
130 V	1000 V dc				0.13004
-130 V	1000 V dc				0.13004
200 mV, 100 Hz	1 V dc				0.00024
200 mV, 1 kHz	1 V dc				0.00024
200 mV, 5 kHz	1 V dc				0.00054
200 mV, 10 kHz	1 V dc				0.00054
2.2 V, 100 Hz	10 V dc				0.00224
2.2 V, 5 kHz	10 V dc				0.00554
2.2 V, 10 kHz	10 V dc				0.00554

**Verification at 50 Ω**

To do a 50 Ω verification:

1. Connect the SCOPE connector of the Calibrator to the HP 3458A input, with the cable and the 50 Ω termination connected to the BNC(f) to Double Banana adapter.
2. Connect the TRIG OUT connector of the Calibrator to the EXT Trig connector on the rear panel of the HP3458A.
3. Make sure the Calibrator impedance is set to 50 Ω (The **Output @** softkey toggles the impedance between 50 Ω and 1 MΩ).
4. Set the HP 3458A to DCV, NPLC = .01, TRIG EXT.
5. Set the HP 3458A DELAY to .0007 for the top part of the waveform (topline) measurement, and .0012 for the lower part of the waveform (baseline). Manually range lock the HP 3458A to the range that gives the most resolution for the topline measurements. Use this same range for the related baseline measurements at each step. See Table 6-8.
6. Push the TRIG softkey on the Calibrator until **1** shows in the display.
7. Measure the topline first as shown in Table 6-8. For each measurement, get samples for 2 seconds minimum, with the HP 3458A MATH functions to retrieve the average or mean value. See the “Setup for SC600 Edge and Wave Generator Measurements” section for more information.
8. Measure the baseline of each output after the topline measurement, as shown in Table 6-8. The peak-to-peak value is the difference between the topline and baseline measurements. Compare the result to the tolerance column.

Table 6-8. AC Voltage Verification at 50 Ω

Calibrator Output (1 kHz)	HP3458A Range	Topline Measurement	Baseline Measurement	Peak-to-Peak	Peak-to-Peak x correction	Tolerance (±V)
1 mV	100 mV dc					0.000043
-1 mV	100 mV dc					0.000043
10 mV	100 mV dc					0.000065
-10 mV	100 mV dc					0.000065
25 mV	100 mV dc					0.000103
-25 mV	100 mV dc					0.000103
110 mV	100 mV dc					0.000315
-110 mV	100 mV dc					0.000315
500 mV	1 V dc					0.00129
-500 mV	1 V dc					0.00129
2.2 V	10 V dc					0.00554
-2.2 V	10 V dc					0.00554
6.6 V	10 V dc					0.01654
-6.6 V	10 V dc					0.01654

**AC Voltage Frequency Verification**

This procedure uses:

- PM 6680 Frequency Counter with an ovenized timebase (Option PM 9690 or PM 9691)
- Output cable supplied with the SC600

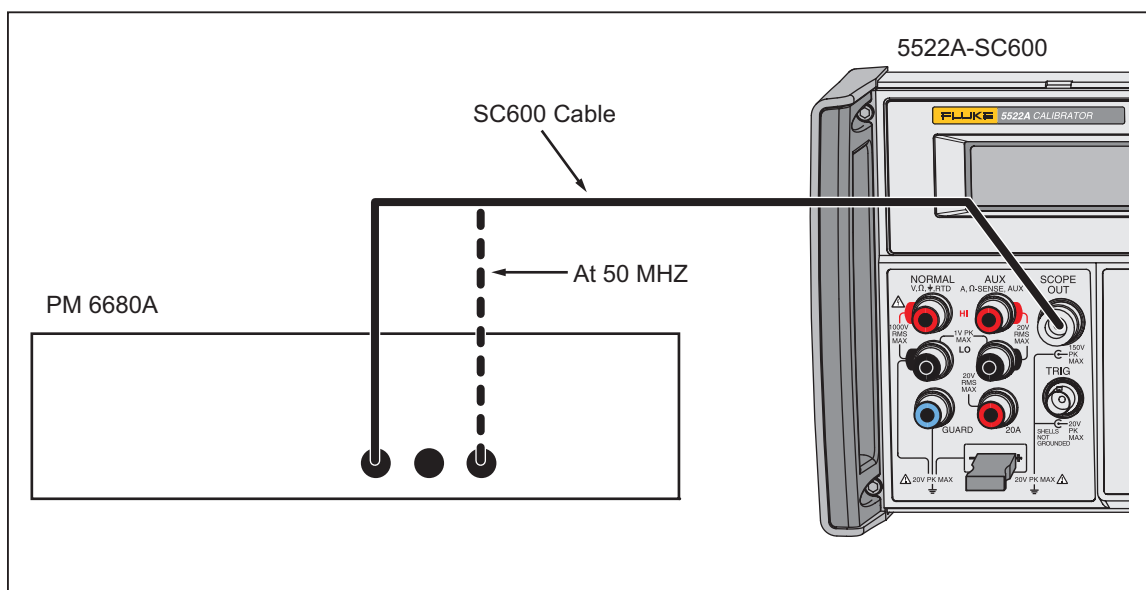

Figure 6-7. AC Voltage Frequency Verification Setup

gjh108.eps

To do an ac voltage frequency verification:

1. Set the Calibrator to SCOPE mode, with the Volt menu shown in the display.
2. Push **OPR** on the Calibrator.
3. Set the FUNCTION of the PM 6680 to measure frequency on channel A with auto trigger, measurement time set to 1 second or longer, 1 MΩ impedance, and filter off.
4. Connect the SCOPE connector on the Calibrator to channel A of the PM 6680 with the output cable. See Figure 6-7.
5. Set the Calibrator to output 2.1 V at each frequency shown in Table 6-9.
6. Let the PM 6680 measurement become stable.
7. Record the PM 6680 measurement for each frequency shown in Table 6-9.
8. Compare to the tolerance column of Table 6-9.

**Table 6-9. AC Voltage Frequency Verification**

Calibrator Frequency	PM 6680 Measurement (Frequency)	Tolerance
10 Hz		0.000025 Hz
100 Hz		0.00025 Hz
1 kHz		0.0025 Hz
10 kHz		0.025 Hz

**Edge Amplitude Verification**

To do an edge amplitude verification:

1. Connect the SCOPE connector of the Calibrator to the HP 3458A input, with the cable and the 50 Ω termination connected to the BNC(f) to Double Banana adapter.
2. For ac voltage output at 1 kHz, set the HP 3458A to DCV, NPLC = .01, LEVEL 1, TRIG LEVEL. For ac voltage output of 10 kHz, change the NPLC to .001.
3. Set the HP3458A DELAY to .0002 for the top part of the waveform (topline) measurement, and .0007 for the lower part of the waveform (baseline).
4. Manually range lock the HP 3458A to the range that gives the most resolution for the baseline measurements. Use this same range for the related baseline measurements at each step. See Table 6-10.

*Note*

*For the edge function, the topline is near 0 V and the baseline is a negative voltage.*

5. For each measurement, get samples for 2 seconds minimum, with the HP 3458A MATH functions to retrieve the average or mean value. See the “Setup for SC600 Edge Wave Generator Measurements” section to learn more.
6. The peak-to-peak value of the waveform is the difference between the topline and baseline measurements. Multiply the measurements by  $(0.5 * (50 + R_{load}) / R_{load})$ , where  $R_{load}$  = the actual feedthrough termination resistance, to correct for the resistance error.
7. Record each measurement in Table 6-10.

**Table 6-10. Edge Amplification Verification**

Calibrator Edge Output	HP3458A Range	Topline Measurement	Baseline Measurement	Peak-to-Peak	Peak-to-Peak x correction	Tolerance ( $\pm V$ )
100 mV, 1 kHz	100 mV dc					0.0022
1.00V, 1 kHz	1 V dc					0.0202
5 mV, 10 kHz	100 mV dc					0.0003
10 mV, 10 kHz	100 mV dc					0.0004
25 mV, 10 kHz	100 mV dc					0.0007
50 mV, 10 kHz	100 mV dc					0.0012
100 mV, 10 kHz	1 V dc					0.0022
500 mV, 10 kHz	1 V dc					0.0102
1.00 V, 10 kHz	1 V dc					0.0202
2.5 V, 10 kHz	10 V dc					0.0502

**Edge Frequency Verification**

This procedure uses:

- PM 6680 Frequency Counter with an ovenized timebase (Option PM 9690 or PM 9691)
- Output cable supplied with the SC600

To do an Edge Frequency Verification:

1. Connect the equipment as shown in Figure 6-7.
2. Set the Calibrator to SCOPE mode, with the edge menu shown in the display.
3. Push **OPR** on the Calibrator.
4. Set the FUNCTION of the PM 6680 to measure frequency on channel A with auto trigger, measurement time set to 1 second or longer, 50  $\Omega$  impedance, and filter off.
5. Connect the SCOPE connector on the Calibrator to channel A of the PM 6680 with the output cable.
6. Set the Calibrator to output 2.5 V at each frequency shown in Table 6-11.
7. Let the PM 6680 measurement become stable.
8. Record the PM 6680 measurement for each frequency shown in Table 6-11.
9. Compare to the tolerance column of Table 6-11.

**Table 6-11. Edge Frequency Verification**

Calibrator Frequency (output @ 2.5 V p-p)	PM 6680 Measurement (Frequency)	Tolerance
1 kHz		0.0025 Hz
10 kHz		0.025 Hz
100 kHz		0.25 Hz

**Table 6-11. Edge Frequency Verification (cont.)**

Calibrator Frequency (output @ 2.5 V p-p)	PM 6680 Measurement (Frequency)	Tolerance
1 MHz		2.5 Hz
10 MHz		25 Hz

**Edge Duty Cycle Verification**

This procedure uses:

- PM 6680 Frequency Counter with an ovenized timebase (Option PM 9690 or PM 9691)
- Output cable supplied with the SC600

To do an Edge Duty Cycle Verification:

1. Connect the equipment as shown in Figure 6-7.
2. Set the Calibrator to SCOPE mode, with the edge menu shown in the display.
3. Push **OPR** on the Calibrator.
4. Set the FUNCTION of the PM 6680 to measure duty cycle on channel A with auto trigger, measurement time set to 1 second or longer, 50 Ω impedance, and filter off.
5. Connect the SCOPE connector on the Calibrator to channel A of the PM 6680 with the output cable.
6. Set the Calibrator to output 2.5 V at 1 MHz.
7. Let the PM 6680 measurement become stable.
8. Compare to the duty cycle measurement to 50 % ±5 %.

**Edge Rise Time Verification**

This verification is a test of the rise time of the edge function. Aberrations are also examined.

This procedure uses:

- High Frequency Digital Storage Oscilloscope: Tektronix 11801 with Tektronix SD-22/26 sampling head
- 3 dB attenuator, 3.5 mm (m/f)
- BNC(f) to 3.5 mm(m) adapter (2)
- Output cable supplied with the SC600
- Second BNC cable

To do an edge rise time verification:

1. Connect the output cable to the SCOPE connector on the Calibrator. Connect the other end of the output cable to one of the BNC(f) to 3.5 mm (m) adapter and then to the sampling head of the DSO through the 3 dB attenuator.
2. Use the second BNC cable with the BNC(f) to 3.5 mm(m) adapter attached to connect the TRIG OUT of the Calibrator to the trigger input of the DSO. See Figure 6-8.

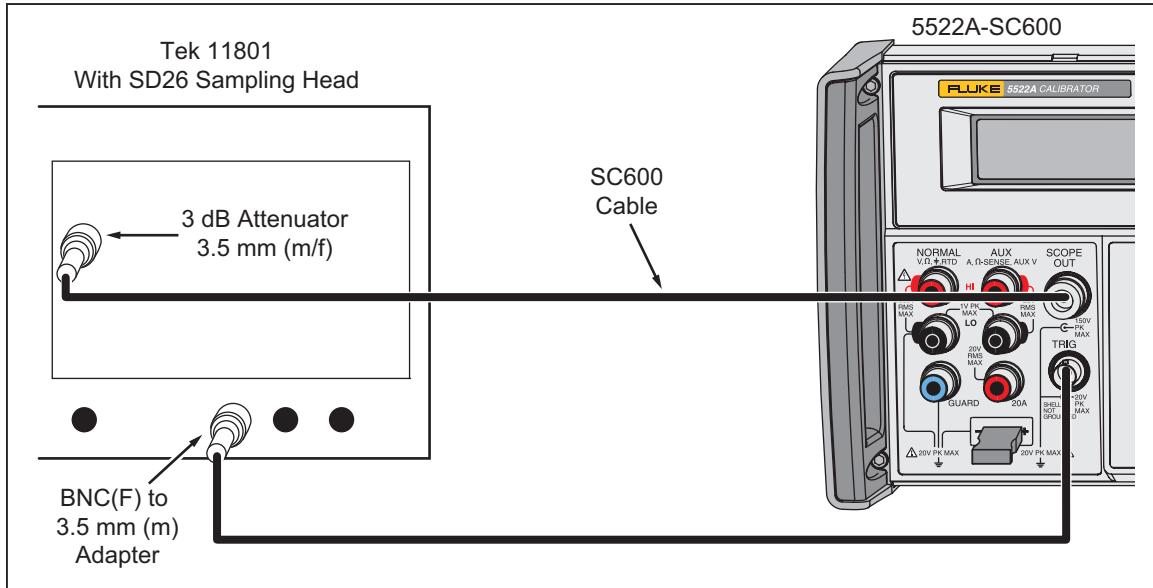

Figure 6-8. Edge Rise Time Verification Setup

gjh109.eps

3. Set the Calibrator to SCOPE mode, with the Edge menu shown in the display.
4. Push **OPR** on the Calibrator.
5. Push the TRIG softkey on the Calibrator until **1** shows in the display.
6. Set the Calibrator output to 250 mV @ 1 kHz.
7. Set the DSO to:
  - Main Time Base: 40 ns
  - Horizontal scale: 500 ps/div
  - Measurement function: Rise Time
8. Set the Calibrator to output the voltage and frequency shown in Table 6-12.
9. Push **OPR** on the Calibrator.
10. Change the vertical scale of the DSO to the value shown in Table 6-12.
11. Adjust the main time base position and vertical offset until the edge signal is in the center of the DSO display.
12. Record the rise time measurement in column A of Table 6-12.
13. Correct the rise time measurement for the rise time of the SD-22/26 sampling head. The SD-22/26 rise time is specified as <28 ps.

$$\text{Column B} = \sqrt{(\text{Column A})^2 - (\text{SD-22/26 rise time})^2}$$

14. The measured edge rise time must be less than the time shown in Table 6-12.

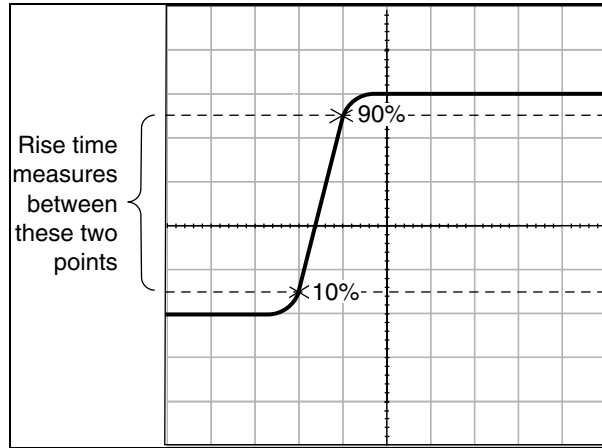

om033i.eps

Figure 6-9. Edge Rise Time

Table 6-12. Edge Rise Time Verification

Calibrator Output		DSO Vertical Axis (mV/div)	A 11801 Measurement	B Corrected Measurement	Tolerance
Voltage	Frequency				
250 mV	1 MHz	20.0			< 300 ps
250 mV	10 MHz	20.0			< 350 ps
500 mV	1 MHz	50.0			< 300 ps
500 mV	10 MHz	50.0			< 350 ps
1 V	1 MHz	100.0			< 300 ps
1 V	10 MHz	100.0			< 350 ps
2.5 V	1 MHz	200.0			< 300 ps
2.5 V	10 MHz	200.0			< 350 ps

### Edged Aberration Verification

This procedure uses:

- Tektronix 11801 oscilloscope with SC22/26 sampling head
- Output cable supplied with the SC600

To do edge aberration verification:

1. Make sure that the SC600 is in the edge mode (the edge menu is shown in the display), and set it to output 1 V p-p @ 1 MHz.
2. Push **OPR**.
3. Connect the Calibrator to the oscilloscope as shown in Figure 6-8.
4. Set the oscilloscope vertical gain to 10 mV/div and horizontal time base to 1 ns/div.
5. Set the oscilloscope to show the 90 % point of the edge signal. Use this point as the reference level.
6. Set the oscilloscope to show the first 10 ns of the edge signal with the rising edge at the left edge of the oscilloscope display.

*Note*

*With this setup, each vertical line of the oscilloscope display shows a 1 % aberration.*

7. Make sure the SC600 meets the specifications shown in Table 6-13.

**Table 6-13. Edge Aberrations**

Time from 50 % of Rising Edge	Typical Edge Aberrations
0 - 2 ns	< 32 mV (3.2%)
2 - 5 ns	< 22 mV (2.2%)
5 - 15 ns	< 12 mV (1.2%)
> 15 ns	< 7 mV (0.7%)

**Tunnel Diode Pulser Drive Amplitude Verification**

This procedure uses:

- Hewlett-Packard 3458A Digital Multimeter
- BNC(f) to Double Banana adapter
- Output cable supplied with the SC600

To do a Diode Pulser Drive Amplitude verification:

1. Set the Calibrator to SCOPE mode, with the edge menu shown in the display.
2. Connect the SCOPE connector of the Calibrator to the HP 3458A input, with the cable and the BNC(f) to Double Banana adapter. See Figure 6-4.
3. Push the **TDPULSE** softkey on the Calibrator.
4. Set the output to 80 V peak-to-peak, 100 kHz, STANDBY.
5. Set the HP 3458A to DCV, NPLC = .01, LEVEL 1, TRIG LEVEL.
6. Set the HP3458A DELAY to .0012 for the top part of the waveform (i.e. topline) measurement, and .0007 for the lower part of the waveform (i.e. baseline).
7. Manually range lock the HP 3458A to the 100 V range.
8. Change the Calibrator Mainframe output frequency to 10 kHz.
9. Push **OPR**, and use the HP 3458A to measure the topline and baseline.
10. The peak-to-peak value is the difference between the topline and baseline. Record these values in Table 6-14, and compare against the tolerance.

**Table 6-14. Tunnel Diode Pulser Amplitude Verification**

Calibrator Edge Output	HP3458A Range	Topline Measurement	Baseline Measurement	Peak-to-Peak	Tolerance (±V)
80 V, 10 kHz	100 V dc				1.6

**Leveled Sine Wave Amplitude Verification**

This procedure uses:

- 5790A AC Measurement Standard
- BNC(f) to Double Banana Plug adapter

- 50 Ω feedthrough termination
- Output cable supplied with the SC600

To do a Leveled Sine Wave Amplitude Verification:

1. Connect the equipment as shown in Figure 6-4.
2. Set the Calibrator to SCOPE mode, with the Levsine menu shown in the display.
3. Push **OPR**.
4. Connect the output cable to the 50 Ω feedthrough termination.
5. Connect the one end of the output cable to the SCOPE connector of the Calibrator
6. Connect the 50 Ω feedthrough termination at the other end of the cable to input 2 of the 5790A with the BNC(f) to Double Banana adapter.
7. Set the 5790A to AUTORANGE, digital filter mode to FAST, restart fine, and Hi Res on.
8. Set the Calibrator to a value shown in column 1 of the Table 6-15.
9. Let the 5790A measurement become stable and then record the 5790A measurement in the table.
10. Multiply the rms measurement by the conversion factor of 2.8284 to get the peak-to-peak value.
11. Multiply the measurements by  $(0.5 * (50 + Rload) / Rload)$ , where Rload = the actual feedthrough termination resistance, to correct for the resistance error.
12. Compare the result to the value in the tolerance column.

**Table 6-15. Leveled Sine Wave Amplitude Verification**

Calibrator Output (@ 50 kHz)	5790A Measurement (V rms)	5790A Measurement x 2.8284 (V p-p)	V p-p Value x correction	Tolerance (V p-p)
5.0 mV				400 μV
7.5 mV				450 μV
9.9 mV				498 μV
10.0 mV				500 μV
25.0 mV				800 μV
39.0 mV				1.08 mV
40.0 mV				1.10 mV
70.0 mV				1.70 mV
99.0 mV				2.28 mV
100.0 mV				2.30 mV
250.0 mV				5.30 mV
399.0 mV				8.28 mV
0.4 V				8.3 mV
0.8 V				16.3 mV
1.2 V				24.3 mV
1.3 V				26.3 V
3.4 V				68.3 mV
5.5 V				110.3 mV

### Leveled Sine Wave Frequency Verification

This procedure uses:

- PM 6680 Frequency Counter with a prescaler for the Channel C input (Option PM 9621, PM 9624, or PM 9625) and ovenized timebase (Option PM 9690 or PM 9691)
- BNC(f) to Type N(m) adapter
- Output cable supplied with the SC600

To do a leveled sine wave frequency verification:

1. Connect the equipment as shown in Figure 6-7.
2. Set the Calibrator to SCOPE mode, with the Levsine menu shown in the display.
3. Set the PM 6680 to the measure frequency function with auto trigger, measurement time set to 1 second or longer, and 50  $\Omega$  impedance.
4. Connect one end of the output cable to the SCOPE connector of the Calibrator.
5. Connect the BNC(f) to Type N(m) adapter to the other end of the output cable.
6. Connect the Type N connector to the PM 6680 channel shown in Table 6-16.
7. Set the filter on the PM 6680 as shown in Table 6-16.
8. Set the Calibrator output to the parameters shown in Table 6-16.
9. Push **OPR**.
10. Let the PM 6680 measurement become stable and then record the frequency measurement in Table 6-16.

**Table 6-16. Leveled Sine Wave Frequency Verification**

Calibrator Frequency (@ 5.5 V p-p)	PM 6680 Settings		PM 6680 Measurement (Frequency)	Tolerance
	Channel	Filter		
50 kHz	A	On		0.125 Hz
500 kHz	A	Off		1.25 Hz
5 MHz	A	Off		12.5 Hz
50 MHz	A	Off		125 Hz
500 MHz	C	Off		1250 Hz

### Leveled Sine Wave Harmonics Verification

This procedure uses:

- Hewlett-Packard 8590A Spectrum Analyzer
- BNC(f) to Type N(m) adapter
- Output cable supplied with the SC600

To do a Leveled Sine Wave Harmonics Verification:

1. Connect the equipment as shown in Figure 6-10.

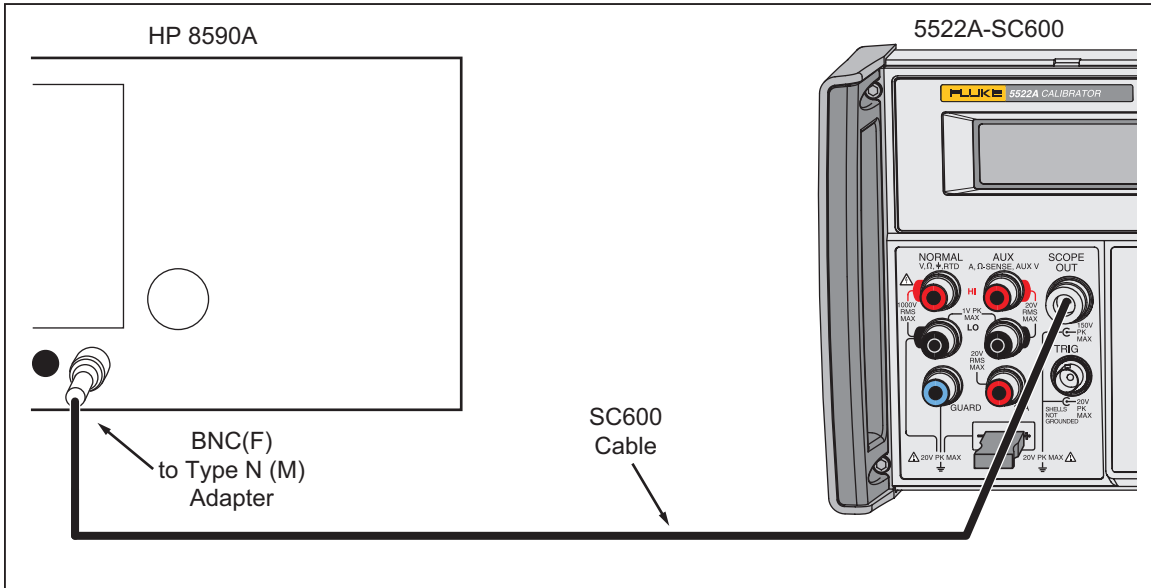

**Figure 6-10. Levelled Sine Wave Harmonics Verification Setup**

gjh110.eps

2. Set the Calibrator to Scope mode with the Levsine menu shown in the display.
3. Connect one end of the Output cable to the SCOPE connector of the Calibrator.
4. Connect the BNC(f) to Type N(m) adapter to the other end of the output cable.
5. Connect the Type N connector to the HP 8590A.
6. Set the Calibrator to output 5.5 V p-p at each frequency on Table 6-17.
7. Push **OPR**.
8. Set the HP 8590A start frequency to the Calibrator output frequency.
9. Set the HP 8590A stop frequency to 10 times the Calibrator output frequency.
10. Set the HP 8590A reference level at +19 dBm.
11. Record the harmonic level measurement for each frequency and harmonic shown in Table 6-17. For harmonics 3, 4, and 5, record the highest harmonic level of the three measured. Harmonics must be below the levels listed in the tolerance column of Table 6-17.

**Table 6-17. Levelled Sine Wave Harmonics Verification**

Calibrator Output Frequency (@ 5.5 V p-p)	Harmonic	HP 8590A Measurement (dB)	Tolerance
50 kHz	2		-33 dB
50 kHz	3, 4, 5		-46 dB
100 kHz	2		-33 dB
100 kHz	3, 4, 5		-38 dB
200 kHz	2		-33 dB
200 kHz	3, 4, 5		-38 dB

Table 6-17. Leveled Sine Wave Harmonics Verification (cont.)

Calibrator Output Frequency (@ 5.5 V p-p)	Harmonic	HP 8590A Measurement (dB)	Tolerance
400 kHz	2		-33 dB
400 kHz	3, 4, 5		-38 dB
800 kHz	2		-33 dB
800 kHz	3, 4, 5		-38 dB
1 MHz	2		-33 dB
1 MHz	3, 4, 5		-38 dB
2 MHz	2		-33 dB
2 MHz	3, 4, 5		-38 dB
4 MHz	2		-33 dB
4 MHz	3, 4, 5		-38 dB
8 MHz	2		-33 dB
8 MHz	3, 4, 5		-38 dB
10 MHz	2		-33 dB
10 MHz	3, 4, 5		-38 dB
20 MHz	2		-33 dB
20 MHz	3, 4, 5		-38 dB
40 MHz	2		-33 dB
40 MHz	3, 4, 5		-38 dB
80 MHz	2		-33 dB
80 MHz	3, 4, 5		-38 dB
100 MHz	2		-33 dB
100 MHz	3, 4, 5		-38 dB
200 MHz	2		-33 dB
200 MHz	3, 4, 5		-38 dB
400 MHz	2		-33 dB
400 MHz	3, 4, 5		-38 dB
600 MHz	2		-33 dB
600 MHz	3, 4, 5		-38 dB

**Leveled Sine Wave Flatness Verification**

Leveled Sine Wave flatness verification is divided into two frequency bands: 50 kHz to 10 MHz (low frequency) and >10 MHz to 600 MHz (high frequency). The equipment setups are different for each band. Leveled Sine Wave flatness is measured relative to 50 kHz. This is a direct measurement in the low frequency band. You must do a

“transfer” measurement at 10 MHz in the high frequency band to calculate a flatness relative to 50 kHz.

### Equipment Setup for Low Frequency Flatness

All low frequency flatness procedures use:

- 5790A/03 AC Measurement Standard with Wideband option
  - BNC(f) to Type N(m) adapter
  - Output cable supplied with the SC600
1. Connect one end of the output cable to the SCOPE connector of the Calibrator.
  2. Connect the BNC(f) to Type N(m) adapter to the other end of the output cable.
  3. Connect the Type N connector to the HP 5790A WIDEBANC input. See Figure 6-11.
  4. Set the HP 5790A to AUTORANGE, digital filter mode to FAST, restart fine, and Hi Res on.

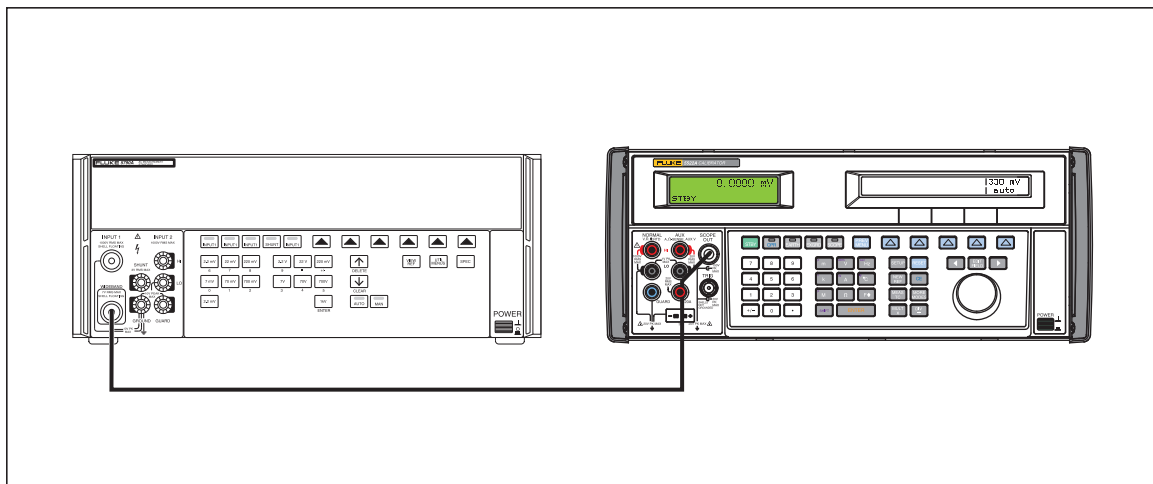

**Figure 6-11. Calibrator to 5790A Measurement Standard Connections**

### Equipment Setup for High Frequency Flatness

All high frequency flatness procedures use:

- Hewlett-Packard 437B Power Meter
- Hewlett-Packard 8482A and 8481D Power Sensors
- BNC(f) to Type N(f) adapter
- Output cable supplied with the SC600

#### Note

*When high frequencies at voltages less than 63 mV p-p are verified, use the 8481D Power Sensor. For voltages 63 mV p-p and higher, use the 8482A Power Sensor.*

Connect the HP 437B Power Meter to the 8482A or the 8481D Power Sensor as shown in Figure 6-12. To learn more about how to connect these two instruments, refer to the operator manuals of the instruments.

Connect the power meter/power sensor combination to the SCOPE connector on the Calibrator. See Figure 6-13.

The HP 437B Power Meter must be configured with:

- PRESET
- RESOLN 3
- AUTO FILTER
- WATTS
- SENSOR TABLE 0 (default)

Zero and self-calibrate the power meter with the power sensor. Refer to the HP 437B operators manual to learn more.

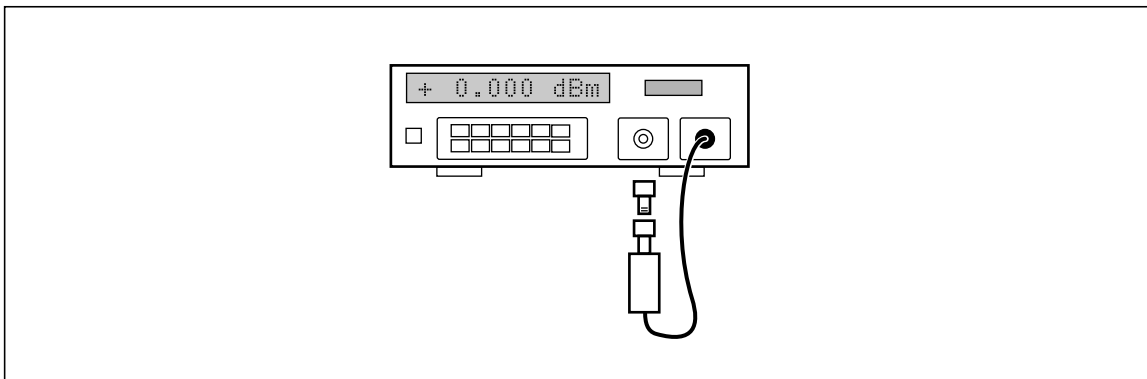

Figure 6-12. HP 437B Power Meter to the HP 8482A or 8481D Power Sensor Connections

om035f.eps

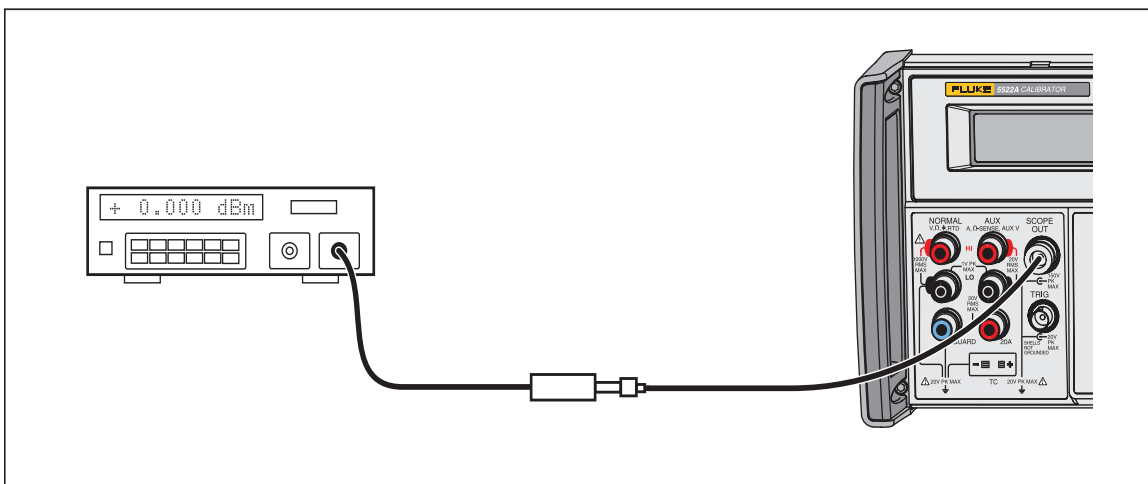

Figure 6-13. Calibrator to the HP Power Meter and Power Sensor Connections

gjh104.eps

### Low Frequency Verification

This procedure gives an example of a low frequency flatness test with a 5.5 V Calibrator output. Use the same procedure for other amplitudes. Compare the results with the flatness specification shown in Table 6-18.

1. Set the Calibrator to output of 5.5 V @ 500 kHz.
2. Push **OPR**.
3. Let the 5790A measurement become stable. The 5790A should display approximately 1.94 V rms.
4. Record the 5790A measurement in column A of Table 6-18.

5. Set the Calibrator frequency to 50 kHz.
6. Let the 5790A measurement become stable and then record the 5790A measurement in column B of Table 6-18.
7. Set the Calibrator to the next frequency shown in Table 6-18.
8. Let the 5790A measurement become stable and then record the measurement in column A of Table 6-18.
9. Set the Calibrator frequency to 50 kHz.
10. Let the 5790A measurement become stable and then record the 5790A measurement in column B of Table 6-18.
11. Do steps 7 through 10 again for all the frequencies shown in Table 6-18. Continue until you have completed Columns A and B.

After you fill in columns A and B for all rows of the table, push **[STBY]**. Use the recorded values in columns A and B to calculate and record the value in column C for all rows.

$$\text{Column C} = 100 \left( \frac{\text{Column A} - \text{Column B}}{\text{Column B}} \right)$$

Compare column C to the specifications shown in the last column.

**Table 6-18. Low Frequency Flatness Verification at 5.5 V**

Calibrator Frequency	A	B 50 kHz	C	Calibrator Flatness Specification (%)
500 kHz				±1.50
1 MHz				±1.50
2 MHz				±1.50
5 MHz				±1.50
10 MHz				±1.50
Fill in Columns A through C as follows: A Record 5790A measurement (mV) for the present frequency. B Record 5790A measurement (mV) for 50 kHz. C Compute and record the Calibrator Flatness deviation (%): $100 * ((\text{Column A}) - (\text{Column B})) / \text{Column B}$				

### High Frequency Verification

This procedure gives an example of a high frequency flatness test with a 5.5 V Calibrator output. Use the same procedure for other amplitudes. Compare the results with the flatness specification shown in Table 6-19.

1. Set the Calibrator to output of 5.5 V @ 30 MHz.
2. Push **[OPR]**.
3. Let the power meter measurement become stable. The power meter measurement should be approximately 75 mW.
4. Record the power meter measurement in column A of Table 6-19.
5. Set the Calibrator frequency to 10 MHz.
6. Let the power meter measurement become stable and then record the measurement in column B of Table 6-19.
7. Set the Calibrator to the next frequency shown in Table 6-19.

8. Let the power meter measurement become stable and then record the measurement in column A of Table 6-19.
9. Set the Calibrator frequency to 10 MHz.
10. Let the power meter measurement become stable and then record the measurement in column B of Table 6-19.
11. Do steps 7 through 10 again for all the frequencies shown in Table 6-19. Continue until you have completed Columns A and B.

When you have filled in columns A and B for all rows of the table, push **[STBY]**. Use the recorded values in columns A and B to calculate and record the value in column C for all rows.

**Table 6-19. High Frequency Flatness Verification at 5.5 V**

Calibrator Frequency (MHz)	A	B (10 MHz)	C	D	E	F	G	Calibrator Flatness Specification (%)
30								±1.50
70								±1.50
120								±2.00
290								±2.00
360								±4.00
390								±4.00
400								±4.00
480								±4.00
570								±4.00
580								±4.00
590								±4.00
600								±4.00
Fill in Columns A through G as follows: A Record the 437B present frequency measurement (W). B Record the 437B 10 MHz measurement (W). C Apply power sensor correction factor for present frequency (W): $CF * (\text{Column A entry})$ . D Apply power sensor correction factor for 10 MHz (W). $CF * (\text{Column B entry})$ E Calculate and record error relative to 10 MHz (%): F Record the 10 MHz rms error (%) for 5.5 V from Table 6-18, column C. G Calculate and record that Calibrator Flatness deviation (%): $(\text{Column E entry}) + (\text{Column F entry})$								

### Time Marker Verification

This procedure uses:

- PM 6680 Frequency Counter with a prescaler for the Channel C input (Option PM 9621, PM 9624, or PM 9625) and ovenized timebase (Option PM 9690 or PM 9691)
- BNC(f) to Type N(m) adapter
- Output cable supplied with the SC600

To do a Time Marker Verification:

1. Connect the equipment as shown in Figure 6-7.
2. Set the PM 6680 to the measure frequency function with auto trigger, measurement time set to 1 second or longer, and 50  $\Omega$  impedance.
3. Set the Calibrator to SCOPE mode, with the Marker menu shown in the display.
4. Push **OPR**.
5. Set the Calibrator output to the parameters shown in Table 6-16.
6. Connect one end of the Output cable to the SCOPE connector of the Calibrator.
7. Connect the BNC(f) to Type N(m) adapter to the other end of the output cable.
8. Connect the Type N connector to the PM 6680 channel shown in Table 6-16.
9. Set the filter on the PM 6680 as shown in Table 6-16.
10. Let the PM 6680 measurement become stable and then record the frequency measurement in Table 6-16.
11. Calculate the period of the frequency with  $\text{Period} = 1/\text{frequency}$  and record it on the table.
12. Compare the period value to the value in the tolerance column.

**Table 6-20. Time Marker Verification**

Calibrator Period	PM 6680 Settings		PM 6680 Measurement		Tolerance
	Channel	Filter	Frequency	Period	
5 s	A	On			0.3489454 s
2 s	A	On			0.0582996 s
50.0 ms	A	Off			3.872E-05 s
20.0 ms	A	Off			5E-08 s
10.0 ms	A	Off			2.5E-08 s
100 ns	A	Off			2.5E-13 s
50.0 ns	A	Off			1.25E-13 s
20.0 ns	A	Off			5E-14 s
10.0 ns	A	Off			2.5E-14 s
5.00 ns	A	Off			1.25E-14 s
2.00 ns	C	Off			5E-15 s

**Wave Generator Verification**

This procedure uses:

- 5790A AC Measurement Standard
- BNC(f) to Double Banana Plug adapter
- 50  $\Omega$  feedthrough termination
- Output cable supplied with the SC600

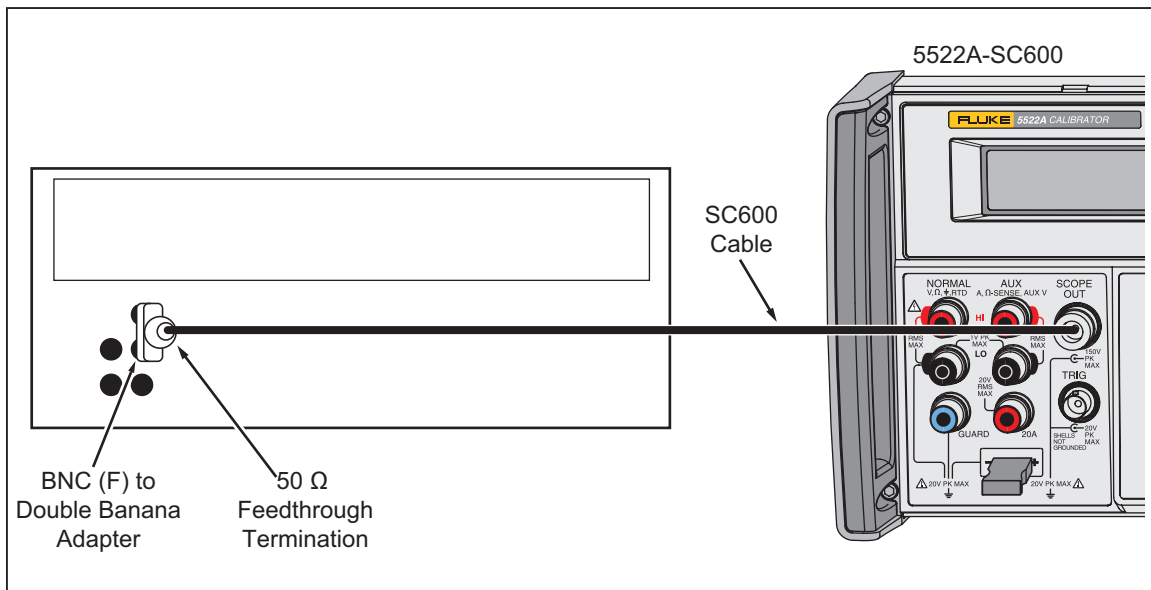

Figure 6-14. Wave Generator Verification Connections

gjh111.eps

Wave Generator Verification is done at two different impedances: 1 M $\Omega$  and 50  $\Omega$ .

### Wave Generator Verification Setup

To setup the equipment for wave generator verification:

1. Connect the equipment as shown in Figure 6-14.
2. Set the Calibrator to SCOPE mode, with the Wavegen menu shown in the display.
3. Push **OPR**.
4. Set offset to 0 mV.
5. Set the Calibrator frequency to 1 kHz.

### Verification at 1 M $\Omega$

1. Set the Calibrator to 1 M $\Omega$ .

#### Note

The **SCOPEZ** softkey toggles the impedance between 50  $\Omega$  and 1 M $\Omega$ .

2. Connect the one end of the output cable to the SCOPE connector of the Calibrator
3. Connect the other end of the cable to input 2 of the 5790A with the BNC(f) to Double Banana adapter.
4. Set the 5790A to AUTORANGE, digital filter mode to FAST, restart fine, and Hi Res on.
5. Set the Calibrator to output the wave type and voltage shown in Table 6-21.
6. Let the 5790A measurement become stable and then record the 5790A measurement for each wave type and voltage in Table 6-21.
7. Multiply the rms measurement by the conversion factor in Table 6-21 to convert the measurement to a peak-to-peak value.
8. Compare the result to the value in the tolerance column.

**Verification at 50Ω**

1. Set the Calibrator to 50 Ω.

*Note*

The **SCOPEZ** softkey toggles the impedance between 50 Ω and 1 MΩ.

2. Connect one end of the output cable to the 50 Ω feedthrough termination.
3. Connect the other end of the output cable to the SCOPE connector of the Calibrator
4. Connect the 50 Ω feedthrough termination at the other end of the cable to input 2 of the 5790A with the BNC(f) to Double Banana adapter.
5. Set the 5790A to AUTORANGE, digital filter mode to FAST, restart fine, and Hi Res on.
6. Set the Calibrator to output the wave type and voltage shown in Table 6-22.
7. Let the 5790A measurement become stable and then record the 5790A measurement for each wave type and voltage in Table 6-22.
8. Multiply the rms measurement by the conversion factor in Table 6-22 to convert the measurement to a peak-to-peak value.
9. Multiply the peak-to-peak value by  $(0.5 * (50 + Rload) / Rload)$ , where Rload = the actual feedthrough termination resistance, to correct for the resistance error.
10. Compare the result to the value in the tolerance column.

**Table 6-21. Wave Generator Verification at 1 MΩ**

Calibrator Wave Type	Calibrator Output (@ 10 kHz)	5790A Measurement (V rms)	Conversion Factor	5790A Measurement x Conversion Factor (V p-p)	Tolerance (V p-p)
square	1.8 mV		2.0000		0.000154 V
square	11.9 mV		2.0000		0.000457 V
square	21.9 mV		2.0000		0.00075 V
square	22.0 mV		2.0000		0.00076 V
square	56.0 mV		2.0000		0.00178 V
square	89.9 mV		2.0000		0.002797 V
square	90 mV		2.0000		0.0028 V
square	155 mV		2.0000		0.00475 V
square	219 mV		2.0000		0.00667 V
square	220 mV		2.0000		0.0067 V
square	560 mV		2.0000		0.0169 V
square	899 mV		2.0000		0.02707 V
square	0.90 V		2.0000		0.0271 V

Table 6-21. Wave Generator Verification at 1 MΩ (cont.)

Calibrator Wave Type	Calibrator Output (@ 10 kHz)	5790A Measurement (V rms)	Conversion Factor	5790A Measurement x Conversion Factor (V p-p)	Tolerance (V p-p)
square	3.75 V		2.0000		0.1126 V
square	6.59 V		2.0000		0.1978 V
square	6.6 V		2.0000		0.1981 V
square	30.8 V		2.0000		0.9241 V
square	55.0 V		2.0000		1.6501 V
sine	1.8 mV		2.8284		0.000154 V
sine	21.9 mV		2.8284		0.000757 V
sine	89.9 mV		2.8284		0.002797 V
sine	219 mV		2.8284		0.00667 V
sine	899 mV		2.8284		0.02707 V
sine	6.59 V		2.8284		0.1978 V
sine	55 V		2.8284		1.6501 V
triangle	1.8 mV		3.4641		0.000154 V
triangle	21.9 mV		3.4641		0.000757 V
triangle	89.9 mV		3.4641		0.002797 V
triangle	219 mV		3.4641		0.00667 V
triangle	899 mV		3.4641		0.02707 V
triangle	6.59 V		3.4641		0.1978 V
triangle	55 V		3.4641		1.6501 V

Table 6-22. Wave Generator Verification at 50 Ω

Calibrator Wave Type	Calibrator Output (@ 10 kHz)	5790A Measurement (V rms)	Conversion Factor	5790A Measurement x Conversion Factor (V p-p)	V p-p value x correction	Tolerance (V p-p)
square	1.8 mV		2.0000			0.000154 V
square	6.4 mV		2.0000			0.000292 V
square	10.9 mV		2.0000			0.000427 V
square	11.0 mV		2.0000			0.00043 V
square	28.0 mV		2.0000			0.00094 V
square	44.9 mV		2.0000			0.001447 V

Table 6-22. Wave Generation Verification at 50 Ω (cont.)

Calibrator Wave Type	Calibrator Output (@ 10 kHz)	5790A Measurement (V rms)	Conversion Factor	5790A Measurement x Conversion Factor (V p-p)	V p-p value x correction	Tolerance (V p-p)
square	45 mV		2.0000			0.00145 V
square	78 mV		2.0000			0.00244 V
square	109 mV		2.0000			0.00337 V
square	110 mV		2.0000			0.0034 V
square	280 mV		2.0000			0.0085 V
square	449 mV		2.0000			0.01357 V
square	450 mV		2.0000			0.0136 V
square	780 mV		2.0000			0.0235 V
square	1.09 V		2.0000			0.0328 V
square	1.10 V		2.0000			0.0331 V
square	1.80 V		2.0000			0.0541 V
square	2.50 V		2.0000			0.0751 V
sine	1.8 mV		2.8284			0.000154 V
sine	10.9 mV		2.8284			0.000427 V
sine	44.9 mV		2.8284			0.001447 V
sine	109 mV		2.8284			0.00337 V
sine	449 mV		2.8284			0.01357 V
sine	1.09 V		2.8284			0.0328 V
sine	2.50 V		2.8284			0.0751 V
triangle	1.8 mV		3.4641			0.000154 V
triangle	10.9 mV		3.4641			0.000427 V
triangle	44.9 mV		3.4641			0.001447 V
triangle	109 mV		3.4641			0.00337 V
triangle	449 mV		3.4641			0.01357 V
triangle	1.09 V		3.4641			0.0328 V
triangle	2.50 V		3.4641			0.0751 V

**Pulse Width Verification**

This procedure uses:

- High Frequency Digital Storage Oscilloscope: Tektronix 11801 with Tektronix SD-22/26 sampling head
- 3 dB attenuator, 3.5 mm (m/f)

- BNC(f) to 3.5 mm(m) adapter (2)
- Output cable supplied with the SC600
- Second BNC cable

To do a pulse width verification:

1. Connect the equipment as shown in Figure 6-8.
2. Connect the output cable to the SCOPE connector on the Calibrator. Connect the other end of the output cable to one of the BNC(f) to 3.5 mm (m) adapter and then to the sampling head of the DSO through the 3 dB attenuator.
3. Use the second BNC cable with the BNC(f) to 3.5 mm(m) adapter attached to connect the TRIG OUT of the Calibrator to the trigger input of the DSO.
4. Set the Calibrator to SCOPE mode, with the Edge menu shown in the display.
5. Push **OPR** on the Calibrator.
6. Push the TRIG softkey on the Calibrator until **I1** shows in the display.
7. Set the DSO to:
  - Main Time Base: 40 ns
  - Vertical scale: 200 mV/div
  - Trigger: source = ext, level = 0.5 V, ext.  
atten. = x10, slope = +, mode = auto
  - Measurement function: positive width
8. Set the Calibrator to the pulse width and period shown in Table 6-23. Set the voltage to 1 V.
9. Change the horizontal scale on the DSO to the value shown in Table 6-23.
10. Adjust the main time base position and vertical offset until the pulse signal is in the center of the DSO display.
11. Record the width measurement.
12. Compare the width measurement to the value in the tolerance column of the table.

**Table 6-23. Pulse Width Verification**

Function/Range	Nominal Value	Measured Value	Low Limit	High Limit
2 $\mu$ s Period/4.00 ns	4.000		1.80	6.20
20 $\mu$ s Period/4.00 ns	4.000		1.80	6.20
200 $\mu$ s Period/4.00 ns	4.000		1.80	6.20
2 ms Period/40.00 ns	40.000		36.00	44.00

### **Pulse Period Verification**

This procedure uses:

- PM 6680 Frequency Counter with an ovenized timebase (Option PM 9690 or PM 9691)
- Output cable supplied with the SC600

To do a pulse period verification:

1. Connect the equipment as shown in Figure 6-7.
2. Set the Calibrator to SCOPE mode, with the Pulse menu shown in the display.
3. Push **OPR** on the Calibrator.
4. Set the PM 6680 to the measure period on channel A with auto trigger, measurement time set to 1 second or longer, 50  $\Omega$  impedance, and filter off.
5. Connect one end of the output cable to the SCOPE connector of the Calibrator.
6. Connect the other end of the output cable to the channel A input of the PM 6680.
7. Set the Calibrator to the pulse width and period shown in Table 6-24. Set the voltage to 2.5V.
8. Let the PM 6680 measurement become stable and then record the period measurement in Table 6-24.
9. Compare the result to the tolerance column.

**Table 6-24. Pulse Period Verification**

Calibrator Output		PM 6680 Measurement	
Width	Period	Period	Tolerance
80 ns	200 ns		5E-13 s
500 ns	10 ms		2.5E-08 s
500 ns	20 ms		5.0E-08 s

### **MeasZ Resistance Verification**

The verification procedure for the MeasZ Resistance function is a resistance measurement of a known value resistance and then compare the measured resistance to the value of the resistor.

This procedure uses:

- Resistors of known values: 1.5 M $\Omega$ , 1 M $\Omega$ , 60  $\Omega$ , 50  $\Omega$ , and 40  $\Omega$  nominal.
- Adapters to connect resistors to a BNC(f) connector.
- Output cable supplied with the SC600

To do a measz resistance verification:

1. Set the Calibrator to SCOPE mode, with the MeasZ menu shown in the display.
2. Set the Calibrator MeasZ resistance range to the value shown in Table 6-25.

*Note*

*The MeasZ softkey toggles the MeasZ ranges.*

3. Connect one end of the output cable to the SCOPE connector of the Calibrator.
4. Connect the resistor shown in Table 6-25 to the other end of the output cable. See Figure 6-6.

*Note*

The resistor must make a solid connection to a BNC(f) connector. The resistance value must be known at this BNC(f) connector. Fluke uses an HP 3458A DMM to make a 4-wire measurement at the BNC(f) connector to get the actual resistance.

5. Let the Calibrator measurement become stable.
6. Record the measurement in Table 6-25.
7. Compare the measured resistance value to the actual resistance of the resistor and the value in the tolerance column of the table.

**Table 6-25. MeasZ Resistance Verification**

Calibrator MeasZ Range	Nominal Resistance Value	Calibrator Resistance Measurement	Actual Resistance Value	Tolerance
res 50Ω	40 Ω			0.04 Ω
res 50Ω	50 Ω			0.05 Ω
res 50Ω	60 Ω			0.06 Ω
res 1MΩ	600 kΩ <sup>[1]</sup>			600 Ω
res 1MΩ	1 MΩ			1 kΩ
res 1MΩ	1.5 MΩ			1.5 kΩ

[1] 600 kΩ is made with the 1.5 MΩ and 1 MΩ resistors connected in parallel.

**MeasZ Capacitance Verification**

The verification procedure for the MeasZ Capacitance function is a capacitance measurement of a known value capacitance and then compare the measured capacitance to the value of the capacitance.

This procedure uses:

- Adapter and capacitors to make 5 pF, 29 pF, and 49 pF nominal values at the end of a BNC(f) connector.
- Output cable supplied with the SC600

To do a MeasZ capacitance verification:

1. Set the Calibrator to SCOPE mode, with the MeasZ menu shown in the display.
2. Set the Calibrator MeasZ capacitance range to **cap**.

*Note*

The MeasZ softkey toggles the MeasZ ranges.

3. Connect one end of the output cable to the SCOPE connector of the Calibrator. Do not connect anything to the other end of this cable.
4. Let the Calibrator measurement become stable and then push the **SET OFFSET** softkey to zero the capacitance measurement.
5. Connect the other end of the cable to the capacitance shown in Table 6-26. See Figure 6-6.
6. Let the Calibrator measurement become stable.

7. Record the measurement in Table 6-26.
8. Compare the measured capacitance value to the actual capacitance and the value in the tolerance column of the table.

**Table 6-26. MeasZ Capacitance Verification**

Nominal Capacitance Value	Calibrator Capacitance Measurement	Actual Capacitance Value	Tolerance
5 pF			0.75 pF
29 pF			1.95 pF
49 pF			2.95 pF

**Overload Function Verification**

This procedure uses:

- 50 Ω feedthrough termination
- Output cable supplied with the SC600

To do an overload function verification:

1. Connect the output cable and 50 Ω feedthrough termination to the Calibrator as shown in Figure 6-15.

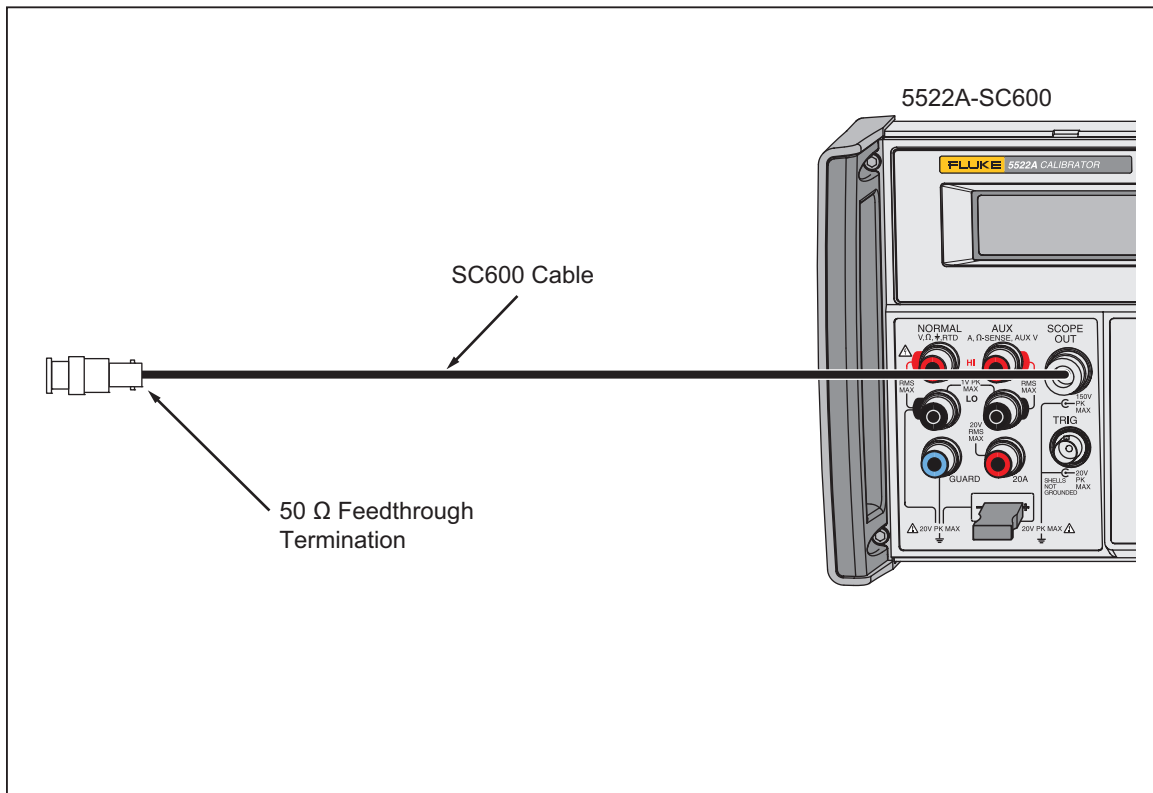

**Figure 6-15. Overload Function Verification Connections**

gjh112.eps

2. Set the Calibrator to SCOPE mode, with the Overload menu shown in the display.
3. Connect one end of the output cable to the 50 Ω feedthrough termination.

4. Connect the other end of the output cable to the SCOPE connector of the Calibrator.
5. Set the Calibrator to output 5.000 V, dc (**OUT VAL** softkey), and time limit = 60 s (**T LIMIT** softkey).
6. Push **OPR** on the Calibrator and make sure the OPR timer display increments.
7. Remove the 50  $\Omega$  feedthrough termination before 60 seconds and make sure the Calibrator goes to standby (**STBY**).
8. Replace the 50  $\Omega$  feedthrough termination on the end of the output cable.
9. Set the Calibrator output to 5.000 V, ac (**OUT VAL** softkey).
10. Push **OPR** on the Calibrator and make sure the OPR timer display increments.
11. Remove the 50  $\Omega$  feedthrough termination before 60 seconds and make sure the Calibrator goes to standby (**STBY**).

## SC600 Hardware Adjustments

Hardware adjustments must be made to the leveled sine and edge functions each time the SC600 is repaired. This section contains the adjustment procedures and a test equipment list with recommended models that are necessary to do these adjustments. Equivalent models can be used if necessary.

### Necessary Equipment

To do the hardware adjustments in this section, you must have:

- Standard adjustment tool to adjust the pots and trimmer caps
- Extender Card
- Oscilloscope Mainframe and Sampling Head (Tektronix 11801 with SD-22/26 or Tektronix TDS 820 with 8 GHz bandwidth)
- 10 dB Attenuator (Weinschel 9-10 (SMA), or Weinschel 18W-10, or equivalent)
- Output cable supplied with the SC600
- Spectrum Analyzer (Hewlett-Packard 8590A)

#### Note

*The models shown in this list are recommended to get accurate results.*

### How to Adjust the Leveled Sine Wave Function

There are two adjustment procedures that you must do for the leveled sine wave function. The first procedure adjusts the balance out of the **LO VCO** so that the signal is balanced between the two VCOs. The second procedure adjusts the harmonics.

### Equipment Setup

This procedure uses the spectrum analyzer. Before you start this procedure, make sure that the Calibrator is in leveled sine wave mode (the Levsine menu shows in the display), and set it to output 5.5 V p-p @ 600 MHz.

1. Push **OPR**.
2. Connect the equipment as shown in Figure 6-10.
3. Adjust the Spectrum Analyzer so that it shows one peak across its horizontal center line in the display. The far right of the peak is fixed at the far right of the center line, as shown in Figure 6-16.

**How to Adjust the Leveled Sine Wave VCO Balance**

To adjust leveled sine wave VCO balance:

*Note*

*The equipment must be setup as described in the Equipment Setup section.*

1. Set the Calibrator to 5.5 V @ 600 MHz.
2. Set the Spectrum Analyzer to:
  - Start frequency            10 MHz
  - Stop frequency:            800 MHz
  - Resolution bandwidth: 30 kHz
  - Video Bandwidth:        3 kHz
  - Reference level:            20 dBm

The spectrum analyzer will show a spur at 153 MHz. See Figure 6-16 to identify the spur.

3. Turn R1 counterclockwise until the spur is at minimum amplitude.

*Note*

*As you turn R1, the spur will move down the waveform in the display. Stop the adjustment with the spur is at minimum amplitude. If you adjust too far, the spur will disappear.*

The signal is balanced between the VCOs and the adjustment is complete when the spur is at minimum amplitude.

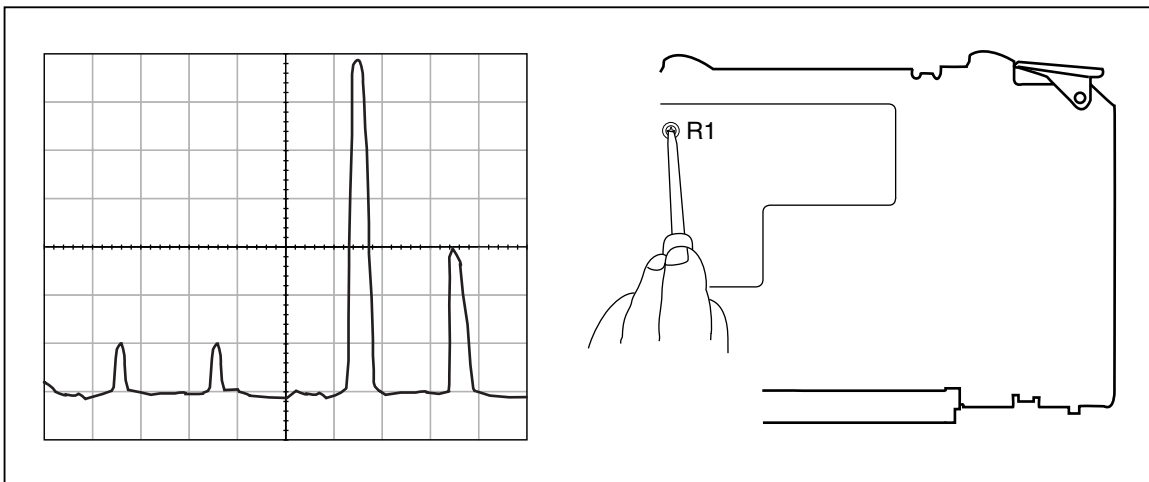

**Figure 6-16. Leveled Sine Wave Balance Adjustment**

om052f.eps

**How to Adjust the Leveled Sine Wave Harmonics**

To adjust the leveled sine wave harmonics:

*Note*

*The equipment must be setup as described in the “Equipment Setup” section.*

1. Set the Calibrator to 5.5 V @ 600 MHz.
2. Set the Spectrum Analyzer to:

- Start frequency: 50 MHz
  - Stop frequency: 500 MHz
  - Resolution bandwidth: 3 MHz
  - Video Bandwidth: 3 kHz
  - Reference level: 20 dBm
3. Use the Peak Search function of the spectrum analyzer to find the reference signal. The spectrum analyzer will show the fundamental and second and third harmonics. The harmonics must be adjusted so that the second harmonic is at 40 dBc and the third harmonic is typically at 50 dBc as shown in Figure 6-17.
  4. Adjust R8 until the peaks of the second and third harmonics are at the correct dB level.

*Note*

*As you adjust, it is possible the second harmonic will be at 40 dBc but the third harmonic is not at 50 dBc. Continue to adjust R8. The second harmonic will change, but there is a point at which the harmonics will be at the correct decibel level.*

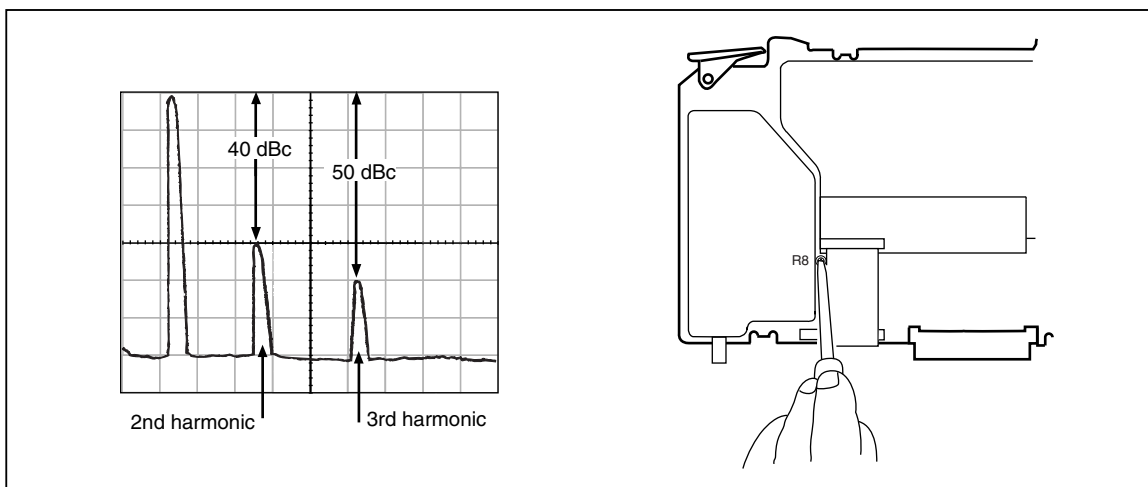

**Figure 6-17. Levelled Sine Wave Harmonics Adjustment**

om051f.eps

**How to Adjust the Aberrations for the Edge Function**

You must do the adjustment procedure after you repair the edge function.

*Note*

*To make sure the edge aberrations are set to national standards, you must send the Calibrator to Fluke, or other company that has traceability for aberrations. Fluke has a reference pulse that is sent to the National Institute of Standards and Technology (NIST) for characterization. This data is then sent to high speed sampling heads, which are used to adjust and verify the SC600.*

**Equipment Setup**

This procedure uses:

- Oscilloscope: Tektronix 11801 with SD22/26 input module or Tektronix TDS 820 with 8 GHz bandwidth.

- 10 dB Attenuator: Weinschel 9-10 (SMA) or Weinschel 18W-10 or an equivalent
- Output cable supplied with the SC600

Before you start the aberration adjustment procedure:

1. Connect the equipment as shown in Figure 6-8.
2. Set the Calibrator to SCOPE mode, with the Edge menu shown in the display.
3. Set the Calibrator to 1 V p-p @ 1 MHz.
4. Push **OPR**.
5. Set the DSO to:
  - Vertical scale: 10 mV/div
  - Horizontal scale: 1 ns/div
6. Set the DSO to show the 90 % point of the edge signal. Use this point as the reference level.
7. Set the DSO to show the first 10 ns of the edge signal with the rising edge at the left edge of the oscilloscope display.

### *How to Adjust the Edge Aberrations*

See Figure 6-18 while you do the adjustment procedure.

1. Adjust A90R13 to set the edge signal at the right edge of oscilloscope display, at 10 ns, to the reference level set above.
2. Adjust A90R36 so the first overshoot is the same amplitude as the subsequent highest aberration.
3. Adjust A90R35 so that the second and third overshoot aberrations are the same amplitude as the first aberration.
4. Adjust A90R12 to set the edge signal to occur between 2 ns and 10 ns to the reference level set above.
5. Adjust A90R36 and A90R35 again to get equal amplitudes for the first, second, and third aberrations.
6. Adjust A90R13 to set the edge signal to occur between 0 ns and 2 ns to the reference point set above. Put the aberrations in the center so the peaks are equal above and below the reference level.
7. Adjust A90R12 again if necessary to keep the edge signal to occur between 2 ns and 10 ns at the reference level.
8. Adjust A90R13 again if necessary to keep the edge signal to occur between 0 ns and 2 ns at the reference level.
9. Set the UUT output to 250 mV and the oscilloscope vertical to 2 mV/div. Examine the aberrations.
10. Connect the 10 dB attenuator to the oscilloscope input. Connect the UUT to the attenuator and set the UUT output to 2.5 V.
11. Set the oscilloscope vertical to 5 mV/div. Examine the aberrations.
12. Make sure the rise time is <300 ps at 250 mV, 1 V, and 2.5 V outputs.

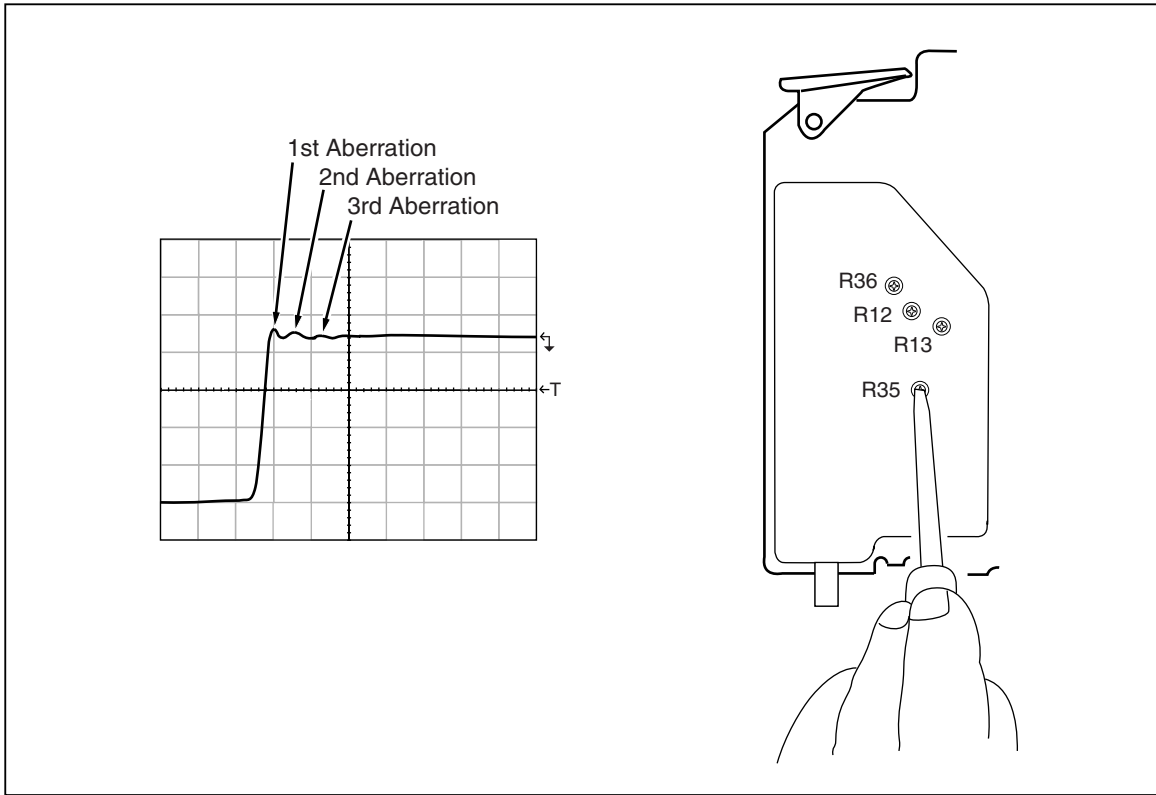

Figure 6-18. Edge Aberrations Adjustment

om050f.eps

# Chapter 7

## **SC1100 Calibration Option**

<b>Title</b>	<b>Page</b>
Introduction.....	7-3
Maintenance.....	7-3
SC1100 Specifications.....	7-3
Volt Specifications .....	7-4
Edge Specifications .....	7-5
Leveled Sine Wave Specifications .....	7-6
Time Marker Specifications .....	7-7
Wave Generator Specifications .....	7-7
Pulse Generator Specifications.....	7-8
Trigger Signal Specifications (Pulse Function).....	7-8
Trigger Signal Specifications (Time Marker Function) .....	7-8
Trigger Signal Specifications (Edge Function) .....	7-8
Trigger Signal Specifications (Square Wave Voltage Function).....	7-8
TV Trigger Signal Specifications .....	7-8
Oscilloscope Input Resistance Measurement Specifications.....	7-9
Oscilloscope Input Capacitance Measurement Specifications .....	7-9
Overload Measurement Specifications.....	7-9
Theory of Operation.....	7-9
Voltage Mode .....	7-9
Edge Mode.....	7-9
Leveled Sine Wave Mode .....	7-9
Time Marker Mode.....	7-9
Wave Generator Mode .....	7-10
Pulse Generator Modes.....	7-10
Input Impedance Mode (Resistance) .....	7-10
Input Impedance Mode (Capacitance).....	7-10
Overload Mode.....	7-10
Equipment Necessary for SC1100 Calibration and Verification .....	7-12
SC1100 Calibration Setup .....	7-15
Calibration and Verification of Square Wave Voltage Functions .....	7-16
Overview of HP 3458A Operation .....	7-16
Voltage Square Wave Measurement Setup .....	7-16
Edge and Wave Gen Square Wave Measurements Setup .....	7-17
DC Voltage Calibration.....	7-18
AC Voltage Calibration.....	7-19
Wave Generator Calibration.....	7-19
Edge Amplitude Calibration.....	7-20
Leveled Sine Wave Amplitude Calibration.....	7-20

Leveled Sine Wave Flatness Calibration.....	7-21
Low Frequency Calibration.....	7-22
High Frequency Calibration.....	7-22
Pulse Width Calibration.....	7-23
MeasZ Calibration.....	7-24
Verification.....	7-26
DC Voltage Verification.....	7-26
Verification at 1 M $\Omega$ .....	7-27
Verification at 50 $\Omega$ .....	7-27
AC Voltage Amplitude Verification.....	7-29
Verification at 1 M $\Omega$ .....	7-30
Verification at 50 $\Omega$ .....	7-31
AC Voltage Frequency Verification.....	7-32
Edge Amplitude Verification.....	7-33
Edge Frequency Verification.....	7-34
Edge Duty Cycle Verification.....	7-35
Edge Rise Time Verification.....	7-35
Edged Aberration Verification.....	7-37
Tunnel Diode Pulser Drive Amplitude Verification.....	7-38
Leveled Sine Wave Amplitude Verification.....	7-39
Leveled Sine Wave Frequency Verification.....	7-40
Leveled Sine Wave Harmonics Verification.....	7-41
Leveled Sine Wave Flatness Verification.....	7-43
Equipment Setup for Low Frequency Flatness.....	7-43
Equipment Setup for High Frequency Flatness.....	7-44
Low Frequency Verification.....	7-45
High Frequency Verification.....	7-46
Time Marker Verification.....	7-57
Wave Generator Verification.....	7-58
Wave Generator Verification Setup.....	7-58
Verification at 1 M $\Omega$ .....	7-58
Verification at 50 $\Omega$ .....	7-59
Pulse Width Verification.....	7-62
Pulse Period Verification.....	7-63
MeasZ Resistance Verification.....	7-63
MeasZ Capacitance Verification.....	7-64
Overload Function Verification.....	7-65
SC1100 Hardware Adjustments.....	7-66
Necessary Equipment.....	7-66
How to Adjust the Leveled Sine Wave Function.....	7-67
Equipment Setup.....	7-67
How to Adjust the Leveled Sine Wave VCO Balance.....	7-67
How to Adjust the Leveled Sine Wave Harmonics.....	7-68
How to Adjust the Aberrations for the Edge Function.....	7-69
Equipment Setup.....	7-69
How to Adjust the Edge Aberrations.....	7-70

## Introduction

This chapter contains information and procedures to do the servicing of the SC1100 Oscilloscope Calibration Option.

The calibration and verification procedures supply traceable results for all of the SC1100 functions while they are done with the recommended equipment. All of the necessary equipment, along with the minimum specifications, are shown in Table 7-1 in the “Equipment Necessary for SC1100 Calibration and Verification” section.

The calibration and verification procedures in this chapter are not the ones Fluke uses at the factory. These procedures were made so you can calibrate and verify the SC1100 at your own site if necessary. Look at all the procedures before you do them to make sure you have the resources to complete them. It is strongly recommended that, if possible, you send your Calibrator to Fluke for calibration and verification.

Hardware adjustments that are made after repair, at the factory, or designated Fluke service centers, are supplied in this manual.

## Maintenance

There are no maintenance procedures or diagnostic remote commands for the SC1100 that are available to users. If your SC1100 is not installed or is not connected to power, the error message in Figure 7-1 shows in the Calibrator display when you push **SCOPE**.

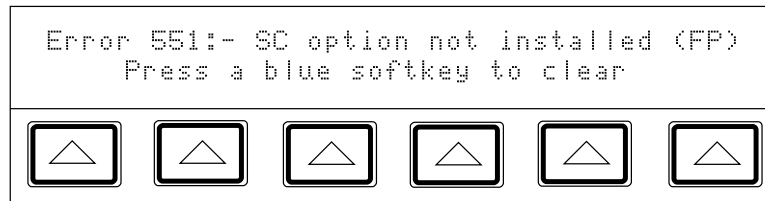

Figure 7-1. Error Message for Scope Option

om030i.eps

If this message shows in the display, and you have the SC1100 installed in the Calibrator, you must send the Calibrator to Fluke for repair. To purchase an SC1100, see your Fluke sales representative.

## SC1100 Specifications

These specifications apply only to the SC1100 Option. General specifications for the Calibrator mainframe can be found in Chapter 1. The specifications are correct for these conditions:

- The Calibrator is operated in the conditions specified in Chapter 1.
- The Calibrator has completed a warm-up period that is two times the period the Calibrator was turned off to a maximum of 30 minutes.
- The SC1100 has been active more than 5 minutes.

**Warmup Time** ..... Twice the time since last warmed up, to a maximum of 30 minutes

**Settling Time** ..... 5 seconds or faster for all functions and ranges

### Temperature Performance

Operating ..... 0 °C to 50 °C

Calibration (tcal)..... 15 °C to 35 °C

Storage ..... -20 °C to +70 °C

**Electromagnetic Compatibility** ..... Designed to operate in Standard Laboratory environments where the Electromagnetic environment is highly controlled. If used in areas with

Electromagnetic fields >1 V/m, there could be errors in output values.  
All testing for this specification used new cables and connectors.

**Temperature Coefficient**..... Temperature Coefficient for temperatures outside tcal +5 °C is 10 % per °C of 1-year specification.

**Relative Humidity**

Operating ..... <80 % to 30 °C, <70 % to 40 °C, <40 % to 50 °C  
Storage ..... <95 %, noncondensing

**Altitude**

Operating ..... 3,050 m (10,000 ft) maximum  
Nonoperating ..... 12,200 m (40,000 ft) maximum

**Safety** ..... Designed to comply with IEC 1010-1 (1992-1); ANSI/ISA-S82.01-1994; CAN/CSA-C22.2 No. 1010.1-92

**Analog Low Isolation**..... 20 V

**EMC**..... Complies with EN 61326-1/1997, Class A

**Volt Specifications**

Volt Function	DC Signal		Square Wave Signal <sup>[1]</sup>	
	50 Ω Load	1 MΩ Load	50 Ω Load	1 MΩ Load
<b>Amplitude Characteristics</b>				
Range	0 to ±6.6 V	0 to ±130 V	±1 mV to ±6.6 V p-p	±1 mV to ±130 V p-p
Resolution	Range 1 to 24.999 mV 25 to 109.99 mV 110 mV to 2.1999 V 2.2 to 10.999 V 11 to 130 V		Resolution 1 μV 10 μV 100 μV 1 mV 10 mV	
Adjustment Range	Continuously adjustable			
1-Year Absolute Uncertainty, tcal ± 5 °C	±(0.25 % of output + 40 μV)	±(0.05 % of output + 40 μV)	±(0.25 % of output + 40 μV)	±(0.1% of output + 40 μV) <sup>[2]</sup>
Sequence	1-2-5 (e.g., 10 mV, 20 mV, 50 mV)			
<b>Square Wave Frequency Characteristics</b>				
Range	10 Hz to 10 kHz			
1-Year Absolute Uncertainty, tcal ± 5 °C	±(2.5 ppm of setting)			
Typical Aberration within 4 μs from 50 % of leading/trailing edge	<(0.5 % of output + 100 μV)			
[1] Selectable positive or negative, zero referenced square wave. [2] For square wave frequencies above 1 kHz, ±(0.25 % of output + 40 μV).				

**Edge Specifications**

Edge Characteristics into 50 Ω Load		1-Year Absolute Uncertainty, tcal ± 5 °C
Rise Time	≤300 ps <sup>[1]</sup>	(+0 ps / -100 ps)
Amplitude Range (p-p)	5.0 mV to 2.5 V	±(2 % of output + 200 μV)
Resolution	4 digits	n/a
Adjustment Range	±10 % around each sequence value (indicated below)	n/a
Sequence Values	5 mV, 10 mV, 25 mV, 50 mV, 60 mV, 80 mV, 100 mV, 200 mV, 250 mV, 300 mV, 500 mV, 600 mV, 1 V, 2.5 V	n/a
Frequency Range	900 Hz to 11 MHz	±(2.5 ppm of setting)
Typical Jitter, edge to trigger	<5 ps (p-p)	n/a
Leading Edge Aberrations <sup>[2]</sup>	within 2 ns from 50 % of rising edge	<(3 % of output + 2 mV)
	2 to 5 ns	<(2 % of output + 2 mV)
	5 to 15 ns	<(1 % of output + 2 mV)
	after 15 ns	<(0.5 % of output + 2 mV)
Typical Duty Cycle	45 % to 55 %	n/a
Tunnel Diode Pulse Drive	Square wave at 100 Hz to 100 kHz, with variable amplitude of 60 V to 100 V p-p.	
[1] Above 2 MHz, the rise time specification is <350 ps. [2] All edge aberration measurements are made with a Tektronix 11801 mainframe with an SD26 input module.		

### Leveled Sine Wave Specifications

Leveled Sine Wave Characteristics into 50 $\Omega$	Frequency Range				
	50 kHz (reference)	50 kHz to 100 MHz	100 to 300 MHz	300 to 600 MHz	600 to 1100 MHz
<b>Amplitude Characteristics (for measuring oscilloscope bandwidth)</b>					
Range (p-p)	5 mV to 5.5 V				5 mV to 3.5 V
Resolution	<100 mV: 3 digits ≥100 mV: 4 digits				
Adjustment Range	continuously adjustable				
1-Year Absolute Uncertainty, tcal $\pm 5^\circ\text{C}$	$\pm(2\% \text{ of output} + 300 \mu\text{V})$	$\pm(3.5\% \text{ of output} + 300 \mu\text{V})$	$\pm(4\% \text{ of output} + 300 \mu\text{V})$	$\pm(6\% \text{ of output} + 300 \mu\text{V})$	$\pm(7\% \text{ of output} + 300 \mu\text{V})$
Flatness (relative to 50 kHz)	not applicable	$\pm(1.5\% \text{ of output} + 100 \mu\text{V})$	$\pm(2\% \text{ of output} + 100 \mu\text{V})$	$\pm(4\% \text{ of output} + 100 \mu\text{V})$	$\pm(5\% \text{ of output} \pm 100 \mu\text{V})$
Short-Term Amplitude Stability	$\leq 1\%^{[1]}$				
<b>Frequency Characteristics</b>					
Resolution	10 kHz				100 kHz
1-Year Absolute Uncertainty, tcal $\pm 5^\circ\text{C}$	$\pm 2.5 \text{ ppm}^{[2]}$				
<b>Distortion Characteristics</b>					
2nd Harmonic	$\leq -33 \text{ dBc}$				
3rd and Higher Harmonics	$\leq -38 \text{ dBc}$				
<p>[1] Within one hour after reference amplitude setting, provided temperature varies no more than <math>\pm 5^\circ\text{C}</math>.</p> <p>[2] With REF CLK set to ext, the frequency uncertainty of the Leveled Sine Wave is the uncertainty of the external 10 MHz clock <math>\pm 0.3 \text{ Hz/gate time}</math>.</p>					

**Time Marker Specifications**

Time Marker into 50 Ω	5s to 50 ms	20 ms to 100 ns	50 to 20 ns	10 ns	5 to 1 ns
1-Year Absolute Uncertainty at Cardinal Points, tcal ± 5 °C [3]	±(25 + t x 1000 ppm) [1]	±2.5 ppm	±2.5 ppm	±2.5 ppm	±2.5 ppm
Wave Shape	spike or square	spike, square, or 20 %-pulse	spike or square	square or sine	sine
Typical Output Level	>1 V p-p [2]	>1 V p-p [2]	>1 V p-p [2]	>1 V p-p [2]	>1 V p-p
Typical Jitter (rms)	<10 ppm	<1 ppm	<1 ppm	<1 ppm	<1 ppm
Sequence	5-2-1 from 5 s to 1 ns (e.g., 500 ms, 200 ms, 100 ms )				
Adjustment Range	At least ±10 % around each sequence value indicated above.				
Amplitude Resolution	4 digits				
[1] t is the time in seconds. [2] Typical rise time of square wave and 20 %-pulse (20 % duty cycle pulse) is <1.5 ns. [3] Away from the cardinal points, add ±50 ppm.					

**Wave Generator Specifications**

Wave Generator Characteristics	Square Wave, Sine Wave, and Triangle Wave into 50 Ω or 1 MΩ
<b>Amplitude</b>	
Range	into 1 MΩ: 1.8 mV to 55 V p-p into 50 Ω: 1.8 mV to 2.5 V p-p
1-Year Absolute Uncertainty, tcal ±5 °C, 10 Hz to 10 kHz	±(3 % of p-p output + 100 μV)
Sequence	1-2-5 (e.g., 10 mV, 20 mV, 50 mV)
Typical DC Offset Range	0 to ± (≥40 % of p-p amplitude) [1]
<b>Frequency</b>	
Range	10 Hz to 100 kHz
Resolution	4 or 5 digits depending upon frequency
1-Year Absolute Uncertainty, tcal ± 5 °C	±(25 ppm + 15 mHz)
[1] The dc offset plus the wave signal must not exceed 30 V rms.	

### Pulse Generator Specifications

Pulse Generator Characteristics	Positive pulse into 50 Ω
Typical rise/fall times	<1.5 ns
Available Amplitudes	2.5 V, 1 V, 250 mV, 100 mV, 25 mV, 10 mV
<b>Pulse Width</b>	
Range	4 to 500 ns <sup>[1]</sup>
Uncertainty (typical)	5 % ±2 ns
<b>Pulse Period</b>	
Range	20 ms to 200 ns (50 Hz to 5 MHz)
Resolution	4 or 5 digits depending upon frequency and width
1-Year Absolute Uncertainty at Cardinal Points, tcal ± 5 °C	±2.5 ppm
[1] Pulse width not to exceed 40 % of period.	
[2] Pulse width uncertainties for periods below 2 μs are not specified.	

### Trigger Signal Specifications (Pulse Function)

Pulse Period	Division Ratio	Amplitude into 50 Ω (p-p)	Typical Rise Time
20 ms to 150 ns	off/1/10/100	≥ 1 V	≤2 ns

### Trigger Signal Specifications (Time Marker Function)

Time Marker Period	Division Ratio	Amplitude into 50 Ω (p-p)	Typical Rise Time
5 s to 35 ms	off/1	≥1 V	≤2 ns
34.9 ms to 750 ns	off/1/10/100	≥1 V	≤2 ns
749 to 7.5 ns	off/10/100	≥1 V	≤2 ns
7.4 to 2 ns	off/100	≥1 V	≤2 ns

### Trigger Signal Specifications (Edge Function)

Edge Signal Frequency	Division Ratio	Typical Amplitude into 50 Ω (p-p)	Typical Rise Time	Typical Lead Time
1 kHz to 10 MHz	off/1	≥1 V	≤2 ns	40 ns

### Trigger Signal Specifications (Square Wave Voltage Function)

Voltage Function Frequency	Division Ratio	Typical Amplitude into 50 Ω (p-p)	Typical Rise Time	Typical Lead Time
10 Hz to 10 kHz	off/1	≥1 V	≤2 ns	2 μs

### TV Trigger Signal Specifications

Trigger Signal Type	Parameters
Field Formats	Selectable NTSC, SECAM, PAL, PAL-M
Polarity	Selectable inverted or uninverted video
Amplitude into 50 Ω (p-p)	Adjustable 0 to 1.5 V p-p into 50 ohm load, (±7 % accuracy)
Line Marker	Selectable Line Video Marker

### Oscilloscope Input Resistance Measurement Specifications

Scope input selected	50 Ω	1 MΩ
Measurement Range	40 to 60 Ω	500 kΩ to 1.5 MΩ
Uncertainty	0.1 %	0.1 %

### Oscilloscope Input Capacitance Measurement Specifications

Scope input selected	1 MΩ
Measurement Range	5 to 50 pF
Uncertainty	±(5 % of input + 0.5 pF) <sup>[1]</sup>
[1] Measurement made within 30 minutes of capacitance zero reference. Scope option must be selected for at least five minutes prior to any capacitance measurement, including the zero process.	

### Overload Measurement Specifications

Source Voltage	Typical 'On' current indication	Typical 'Off' current indication	Maximum Time Limit DC or AC (1 kHz)
5 to 9 V	100 to 180 mA	10 mA	setable 1 to 60 s

## Theory of Operation

This section contains a brief overview of the SC1100 operation modes. This information will let you identify which of the main plug-in PCAs of the Calibrator Mainframe are defective. Figure 7-2 shows a block diagram of the SC1100 Option (also referred to as the A45 PCA). Functions that are not shown in the figure are sourced from the DDS Assembly (A6 PCA). See Chapter 2 for a diagram of all Calibrator Mainframe PCA assemblies.

### Voltage Mode

All signals for the voltage function come from the A41 Voltage/Video PCA, a daughter card to the A45 PCA. A dc reference voltage is supplied to the A41 PCA from the A6 DDS PCA. All dc and ac oscilloscope output voltages are derived from this signal and sourced on the A41 PCA. The output of the A41 PCA goes to the A45 Signal PCA (also attached to the A45 PCA) and attenuator module and is then cabled to the output connectors on the front panel. The reference dc signal is used to supply + and - dc and ac signals that are amplified or attenuated to supply the range of output signals.

### Edge Mode

The DDC A6 PCA is the source of the edge clock and goes to the A45 PCA. The signal is then shaped and divided to supply the fast edge and external trigger signals. The edge signal comes from the A45 PCA first to the attenuator assembly (where range attenuation occurs) and then to the SCOPE connector BNC on the front panel. If turned on, the trigger is connected to the Trig Out BNC on the front panel.

### Leveled Sine Wave Mode

All of the leveled sine wave signals (from 50 kHz to 1100 MHz) are supplied from the A45 PCA. For frequencies 50 kHz to 600 MHz, the A45 PLL and output amplifier is used. For 600 MHz and above, the A92 PLL and output amplifier is used. The leveled sine wave signal comes from the A45 PCA to the on-board PCA attenuator assembly. The attenuator assembly supplies range attenuation and also contains a power detector which keeps amplitude flatness across the frequency range. The signal is then applied to the SCOPE connector on the front panel.

### Time Marker Mode

There are three primary “ranges” of time marker operation: 5 s to 50 ms, 10 ms to 2 μs, and 1 μs to 1 ns.

The A6 DDS PCA is the source of the 5 s to 20 ms markers and are sent to the A45 PCA. The signal path is also divided to supply the external trigger circuitry on the A45 PCA. If turned on, the trigger is connected to the Trig Out BNC on the front panel. The marker signal that goes through the A45 PCA is connected to the attenuator assembly. The signal is then applied to the SCOPE connector on the front panel.

The 10 ms to 2  $\mu$ s markers are derived from a square wave signal that comes from the A6 PCA and is applied to the A45 PCA for wave shaping and external trigger generation. If the trigger is turned on, the signal is connected to the Trig Out BNC on the front panel. The marker signal on the A45 PCA goes to the attenuator assembly and then to the SCOPE connector on the front panel.

The leveled sine wave generator on the A45 PCA is the source of the 1  $\mu$ s to 2 ns markers. This signal is also divided to drive the external trigger circuits. If the trigger is turned on, the signal is then connected to the Trig Out BNC on the front panel. The other path sends the signal to the marker circuits on the A45 PCA, where the signal is shaped into the other marker waveforms. The marker signals on the A45 PCA go to the attenuator assembly and then to the SCOPE connector on the front panel.

### **Wave Generator Mode**

All signals for the wavegen function come from the A6 PCA and go to the A45 PCA. They then go to the attenuator assembly, where range attenuation occurs. Wavegen signals are then sent to the SCOPE connector on the front panel.

### **Pulse Generator Modes**

Video and pulse generator mode signals are derived from dedicated circuitry on the A45 PCA. If there are faults related only to these functions, then the A45 PCA is most likely defective.

### **Input Impedance Mode (Resistance)**

The reference resistors for this mode are on the A45 PCA, while the DCV reference signal and measurement signals are on the A6 DDS PCA.

### **Input Impedance Mode (Capacitance)**

The A45 PCA contains the capacitance measurement circuits, that uses signals from the leveled sine wave source. If there are faults related only to capacitance measurement, then the A45 PCA is most likely defective.

### **Overload Mode**

The A41 Voltage/Video PCA of the A45 PCA supplies the voltage for the overload mode. The voltage is applied to the external 50  $\Omega$  load, and the circuit current is monitored by the A6 DDS PCA.

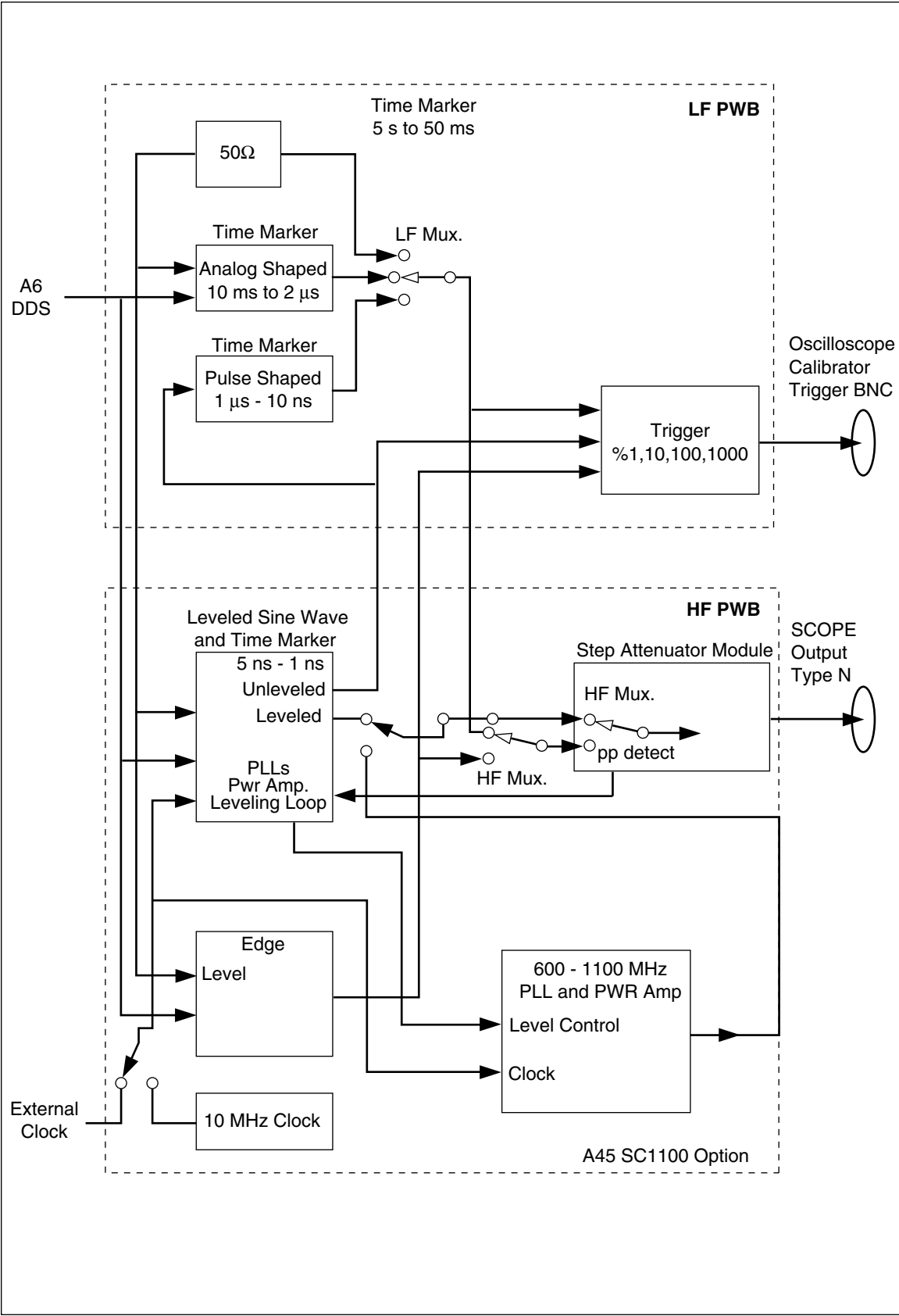

Figure 7-2. SC1100 Block Diagram

ze031f.eps

## Equipment Necessary for SC1100 Calibration and Verification

Table 7-1 is a list of equipment necessary for calibration and verification of the SC1100 Oscilloscope Option.

**Table 7-1. SC1100 Calibration and Verification Equipment**

<b>Wave Generator and Edge Amplitude Calibration, AC Voltage and TD Pulser Equipment</b>			
<b>Instrument</b>	<b>Model</b>	<b>Minimum Use Specifications</b>	
Digital Multimeter	HP 3458A	Voltage	1.8 mV to $\pm 130$ V p-p Uncertainty:0.06 %
		Edge	4.5 mV to 2.75 V p-p Uncertainty:0.06 %
Adapter	Pomona #1269	BNC(f) to Double Banana Plug	
Termination		Feedthrough $50 \Omega \pm 1$ % (used with edge amplitude Calibration and ac voltage verification)	
SC1100 Cable (N-BNC)	(supplied with SC1100)	Type N to BNC	
<b>Edge Rise Time and Aberrations Verification</b>			
High-Frequency Digital Storage Oscilloscope	Tektronix 11801 with Tektronix SD-22/26 sampling head, or Tektronix TDS 820 with 8 GHz bandwidth	Frequency	12.5 GHz
		Resolution	4.5 mV to 2.75 V
Attenuator	Weinschel 9-10 (SMA) or Weinschel 18W-10 or equivalent	10 dB, 3.5 mm (m/f)	
Adapter		BNC(f) to 3.5 mm(m)	
SC1100 Cable (N-BNC)	(supplied with SC1100)	Type N to BNC	
BNC-BNC Cable		For Trigger Out Connection	
<b>Leveled Sine Wave Amplitude Calibration and Verification</b>			
AC Measurement Standard	Fluke 5790A	Range	5 mV p-p to 5.5 V p-p
		Frequency	50 kHz
Adapter	Pomona #1269	BNC(f) to Double Banana Plug	
Termination		Feedthrough $50 \Omega \pm 1$ %	
SC1100 Cable (N-BNC)	(supplied with SC1100)	Type N to BNC	

**Table 7-1. SC1100 Calibration and Verification Equipment (cont.)**

<b>DC and AC Voltage Calibration and Verification, DC Voltage Verification</b>			
<b>Instrument</b>	<b>Model</b>	<b>Minimum Use Specifications</b>	
Digital Multimeter	HP 3458A		
Adapter	Pomona #1269	BNC(f) to Double Banana Plug	
Termination		Feedthrough 50 $\Omega$ $\pm$ 1 %	
SC1100 Cable (N-BNC)	(supplied with SC1100)	Type N to BNC	
BNC-BNC Cable		For Trigger Out Connection	
<b>Pulse Width Calibration and Verification</b>			
High-Frequency Digital Storage Oscilloscope	Tektronix 11801 with Tektronix SD-22/26 sampling head		
Attenuator		3 dB, 3.5 mm (m/f)	
Adapter (2)		BNC(f) to 3.5 mm(m)	
SC1100 Cable (N-BNC)	(supplied with SC1100)	Type N to BNC	
BNC-BNC Cable		For Trigger Out Connection	
<b>Leveled Sine Wave Frequency Verification</b>			
Frequency Counter	PM 6680 with option (PM 9621, PM 9624, or PM 9625) and (PM 9690 or PM 9691)	50 kHz to 600 MHz, <0.15 ppm uncertainty	
Adapter	Pomona #3288	BNC(f) to Type N(m)	
SC1100 Cable (N-BNC)	(supplied with SC1100)	Type N to BNC	
<b>Leveled Sine Wave Flatness (Low Frequency) Calibration and Verification</b>			
AC Measurement Standard	Fluke 5790A with -03 option	Range	5 mV p-p to 5.5 V p-p
		Frequency	50 kHz to 10 MHz
Adapter	Pomona #3288	BNC(f) to Type N(m)	
SC1100 Cable (N-BNC)	(supplied with SC1100)	Type N to BNC	
<b>Leveled Sine Wave Harmonics Verification</b>			
Spectrum Analyzer	HO 8509A		
Adapter	Pomona #3288	BNC(f) to Type N(m)	
SC1100 Cable (N-BNC)	(supplied with SC1100)	Type N to BNC	

Table 7-1. SC1100 Calibration and Verification Equipment (cont.)

Pulse Period, Edge Frequency, AC Voltage Frequency Verification			
Instrument	Model	Minimum Use Specifications	
Frequency Counter	PM 6680 with option (PM 9690 or PM 9691)	20 ms to 150 ns, 10 Hz to 10 MHz: <0.15 ppm uncertainty	
SC1100 Cable (N-BNC)	(supplied with SC1100)	Type N to BNC	
Edge Duty Cycle			
Frequency Counter	PM 6680		
SC1100 Cable (N-BNC)	(supplied with SC1100)	Type N to BNC	
Overload Functional Verification			
Termination		Feedthrough 50 $\Omega$ $\pm$ 1 %	
SC1100 Cable (N-BNC)	(supplied with SC1100)	Type N to BNC	
MeasZ Resistance, Capacitance Verification			
Resistors		1 M $\Omega$ and 50 $\Omega$ nominal values	
Capacitors		50 pF nominal value at the end of BNC(f) connector	
Adapters		To connect resistors and capacitors to BNC(f) connector	
SC1100 Cable (N-BNC)	(supplied with SC1100)	Type N to BNC	
Leveled Sine Wave Flatness (High Frequency) Calibration and Verification			
Power Meter	Hewlett-Packard 437B	Range	-42 dBm to +5.6 dBm
		Frequency	10 MHz to 1100 MHz
Power Sensor	Hewlett-Packard 8482A	Range	-20 dBm to +19 dBm
		Frequency	10 MHz to 1100 MHz
Power Sensor	Hewlett-Packard 8481D	Range	-42 dBm to -20 dBm
		Frequency	10 MHz to 1100 MHz
30 dB Reference Attenuator	Hewlett-Packard 11708A (supplied with HP 8481D)	Range	30 dB
		Frequency	50 MHz
Adapter	Hewlett-Packard PN 1250-1474	BNC(f) to Type N(f)	
SC1100 Cable (N-BNC)	(supplied with SC1100)	Type N to BNC	

**Table 7-1. SC1100 Calibration and Verification Equipment (cont.)**

<b>Leveled Sine Wave Frequency, Time Marker Verification</b>			
<b>Instrument</b>	<b>Model</b>	<b>Minimum Use Specifications</b>	
Frequency Counter	PM 6680 with option (PM 9621, PM 9624, or PM 9625) and (PM 9690 or PM 9691)	2 ns to 5 s, 50 kHz to 600 MHz: <0.15 ppm uncertainty	
Adapter	Pomona #3288	BNC(f) to Type N(m)	
SC1100 Cable (N-BNC)	(supplied with SC1100)	Type N to BNC	
<b>Wave Generator Verification</b>			
AC Measurement Standard	Fluke 5790A with -03 option	Range	1.8 mV p-p to 55 V p-p
		Frequency	10 Hz to 100 kHz
Adapter	Pomona #1269	BNC(f) to Double Banana Plug	
Termination		Feedthrough 50 $\Omega$ $\pm$ 1 %	
SC1100 Cable (N-BNC)	(supplied with SC1100)	Type N to BNC	

## SC1100 Calibration Setup

The procedures in this manual were made to let users calibrate the SC1100 at their own site if it becomes necessary to do so. It is strongly recommended that, if possible, you send your Calibrator to Fluke for calibration and verification. The Calibrator Mainframe must be fully calibrated before you do calibration of the SC1100.

The hardware adjustments are intended to be one-time adjustments done in the factory. Some times adjustment can be necessary after repair. Hardware adjustments must be done before calibration. Calibration must be done after if hardware adjustments are made. See the “Hardware Adjustments” section in this chapter.

The AC Voltage function is dependent on the DC Voltage function. Calibration of the AC Voltage function is necessary after the DC Voltage is calibrated.

The Calibrator Mainframe must complete a warm-up period and the SC1100 must be turned on for a minimum of 5 minutes before you start calibration. This lets internal components become thermally stable. The Calibrator Mainframe warm-up period is a minimum of two times the period the calibrator was turned off, or a maximum of 30 minutes. Push c to turn on the SC1100. The green LED on the SCOPE key is illuminated when the SC1100 is turned on.

Most of the SC1100 Option can be calibrated from the front panel. Push **SCOPE** to turn on the SC1100 and wait a minimum of 5 minutes. To start the Scope Cal mode:

1. Push **SETUP**.
2. Push the **CAL** softkey.
3. Push the **CAL** softkey again.
4. Push the **SCOPE CAL** softkey.

*Note*

*If you push the **Scope Cal** softkey sooner than 5 minutes after you pushed **SCOPE**, a warning message shows in the display.*

All equipment used to calibrate the SC1100 must be calibrated, certified traceable if traceability is to be kept, and operated in their specified operation environment.

It is also important to make sure that the equipment has had sufficient time to warm up before you start calibration. Refer to the operation manual for each piece of equipment for more information.

Before you start calibration, look at all of the procedures to make sure you have the resources to do them.

The Calibrator starts calibration with the DC Voltage function. If it is necessary to start with a different function, push the **OPTIONS** softkey. Then push the **NEXT SECTION** softkey until you see the function name in the display.

## Calibration and Verification of Square Wave Voltage Functions

The Voltage, Edge, and Wave Generator functions have square wave voltages that must be calibrated or verified. The HP 3458A digital multimeter can be programmed from the front panel or through the remote interface to make these measurements.

### Overview of HP 3458A Operation

The Hewlett-Packard 3458A digital multimeter is configured as a digitizer to measure the peak-to-peak value of the signal. It is set to DCV, with different analog-to-digital integration times and trigger commands to measure the topline and baseline of the square wave signal.

### Voltage Square Wave Measurement Setup

To make accurate and repeatable measurements of the topline and baseline of a voltage square wave with a maximum frequency of 10 kHz, set the integration and sample time of the HP 3458A. For this measurement, connect the external trigger of the HP 3458A to the external trigger output of the SC1100. Set the HP 3458A to make an analog-to-digital conversion after it senses the falling edge of an external trigger.

The conversion does not occur until after the delay set by the HP 3458A “DELAY” command. The frequency measured by the DMM influences the actual integration time. Table 7-2 summarizes the DMM settings necessary to make topline and baseline measurements. Figure 7-3 illustrates the correct connections for this setup.

Table 7-2. Voltage HP 3458A Settings

Voltage Input Frequency	HP 3458A Settings		
	NPLC	DELAY (topline)	DELAY (baseline)
100 Hz	0.1	0.007 s	0.012 s
1 kHz	0.01	0.0007 s	0.0012 s
5 kHz	0.002	0.00014	0.00024
10 kHz	0.001	0.00007	0.00012

For all measurements, the HP 3458A is in DCV, manual range, with external trigger turned on. A convenient method to make these measurements from the front panel of the HP 3458A is to put these parameters into some of the user-defined keys. For example, to make topline measurements at 1 kHz, you set the DMM to “NPLC .01; DELAY .0007; TRIG EXT”. To find the average of multiple measurements, you can set one of the keys to “MATH OFF; MATH STAT” and then use the “RMATH MEAN” function to recall the average or mean value.

*Note*

*For this application, if you make measurements of a signal >1 kHz, the HP 3458A can show .05 % to .1 % peaking in the 100 mV range. For these signals, lock the HP 3458A to the 1 V range.*

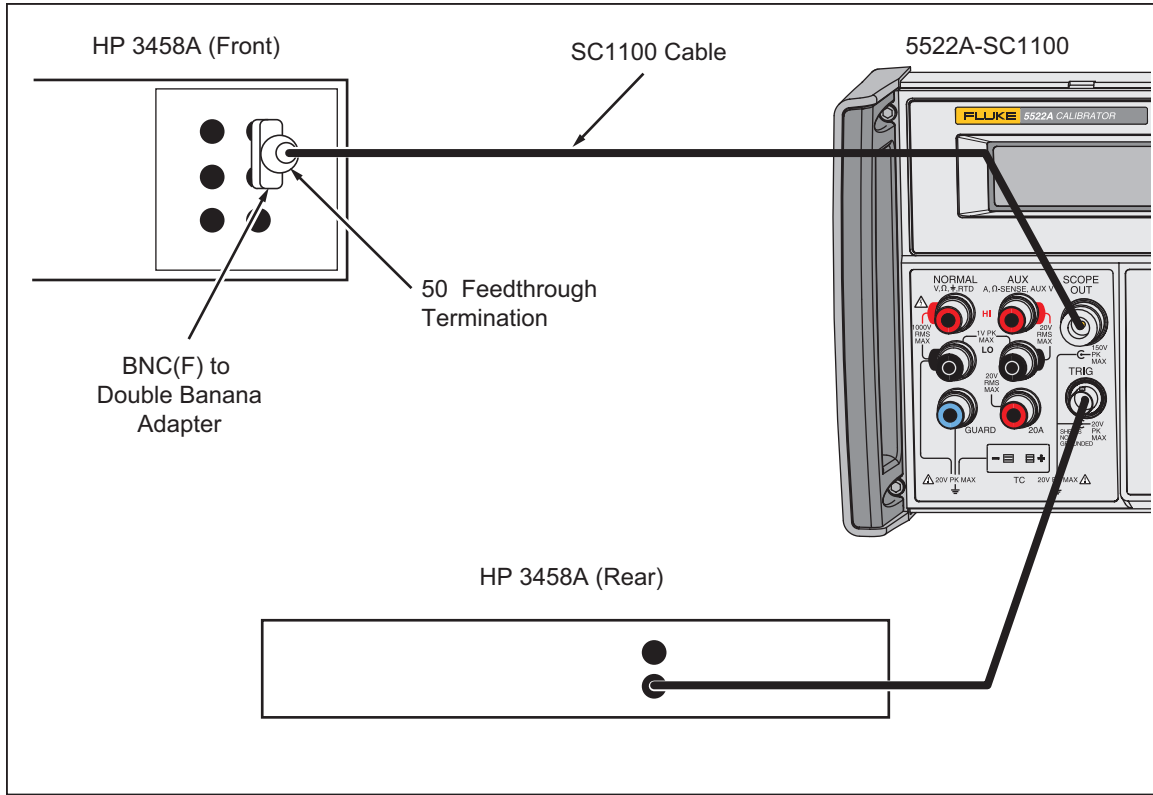

**Figure 7-3. Equipment Setup for SC1100 Voltage Square Wave Measurements**

gjh134.eps

**Edge and Wave Gen Square Wave Measurements Setup**

The setup to measure the topline and baseline of Edge and Wave Generator signals is a little different from the Voltage Square Wave method given above. The HP 3458A is triggered by a change in input level rather than an external trigger. The trigger level is set to 1 % of the DCV range, with ac coupling of the trigger signal. The delay after the trigger event is also changed for the Edge and Wave Generator functions. See Table 7-3 and Figure 7-4.

**Table 7-3. Edge and Wave Generator HP 3458A Settings**

Voltage Input Frequency	HP 3458A Settings		
	NPLC	DELAY (topline)	DELAY (baseline)
1 kHz	0.01	0.0002 s	0.0007 s
10 kHz	0.001	0.00002 s	0.00007 s

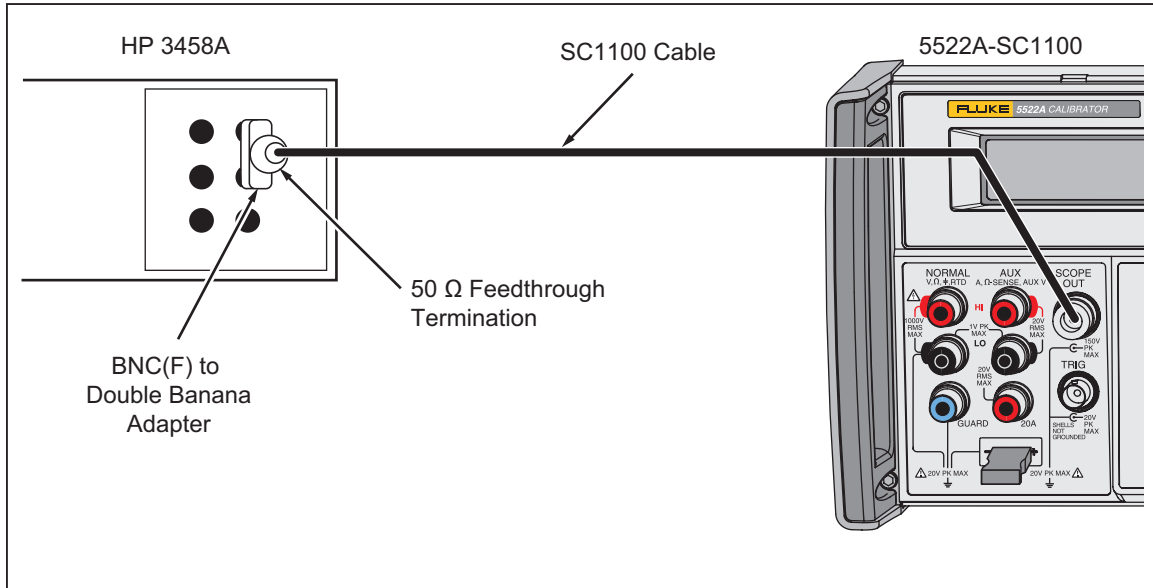

Figure 7-4. Equipment Setup for SC1100 Edge and Wave Gen Square Wave Measurement

gjh135.eps

For all measurements, the HP 3458A is in DCV, manual range, with level triggering enabled. A convenient method to make these measurements from the front panel of the HP 3458A is to put these parameters into some of the user-defined keys. For example, to make topline measurements at 1 kHz, you set the DMM to “NPLC .01; LEVEL 1; DELAY .0002; TRIG LEVEL”. To find the average of multiple measurements, you can set one of the keys to “MATH OFF; MATH STAT” and then use the “RMATH MEAN” function to recall the average or mean value. Refer to Figure 7-4 for the correct connections.

### DC Voltage Calibration

This procedure uses:

- Hewlett-Packard 3458A Digital Multimeter
- BNC(f) to Double Banana adapter
- Output cable supplied with the SC1100
- BNC-BNC cable

#### Note

*AC voltage calibration is necessary for dc voltage calibration.*

See Figure 7-4 for the correct equipment connections.

Set the Calibrator Mainframe in Scope Cal mode, DC Voltage section. To calibrate DC Voltage:

1. Connect the SCOPE connector of the Calibrator to the HP 3458A input, with the output cable and the BNC(f) to Double Banana adapter.
2. Set the HP 3458A to DCV, Auto Range, NPLC = 10, FIXEDZ = on.
3. Push the **GO ON** softkey.
4. Make sure the HP 3458A measurement is 0.0 V DC  $\pm 10 \mu\text{V}$ . If not, adjust R121 on A41. R121 is a square one turn pot and has a mark on the PCA near Q29.
5. Push the **GO ON** softkey.
6. Calibration voltages 33 V and higher automatically put the Calibrator output in

standby. When this occurs, push **OPR** on the Calibrator to output the signal. Let the HP 3458A DC voltage measurement become stable. Type in the measurement through the Calibrator keypad and then push **ENTER**.

*Note*

*The Calibrator will show a message if the typed in value is higher or lower than the limits of the value. If this occurs, examine the setup and carefully re-type in the measurement with the correct multiplier (m,  $\mu$ , n, p). If the warning continues, repair may be necessary.*

7. Do step 6 again until the Calibrator shows that the subsequent steps calibrate ac voltage. Push the **OPTIONS**, then **STORE CONSTS** softkeys to store the new calibration constants.

AC voltage must be calibrated: continue with the subsequent section.

### **AC Voltage Calibration**

This procedure uses the same equipment and setup as DC Voltage calibration. Refer to Figure 7-4. DC voltages are measured and typed in to the Calibrator to calibrate the AC Voltage function.

To calibrate the Calibrator for ac voltage:

1. Push the **OPTIONS** softkey.
2. Push the **NEXT SECTION** softkey until “The next steps calibrate –SC1100 ACV” shows in the display.
3. Push the **GO ON** softkey.
4. Let the HP3485A voltage measurement become stable.
5. Type in the measurement through the keypad of the Calibrator.
6. Push **ENTER**.

*Note*

*The Calibrator will show a message if the typed in value is higher or lower than the limits of the value. If this occurs, examine the setup and carefully re-type in the measurement with the correct multiplier (m,  $\mu$ , n, p). If the warning continues, repair may be necessary.*

7. Do step 4 again until the Calibrator shows that the subsequent steps calibrate WAVGEN. Push the **OPTIONS**, then **STORE CONSTS** softkeys to store the new calibration constants.

### **Wave Generator Calibration**

This procedure uses:

- Hewlett-Packard 3458A Digital Multimeter
- BNC(f) to Double Banana adapter
- Output cable supplied with the SC1100

To calibrate the wave generator:

1. Push the **OPTIONS** softkey.
2. Push the **NEXT SECTION** softkey until “WAVEGEN Cal:” shows in the display.
3. Connect the SCOPE connector of the Calibrator to the HP 3458A input with the output cable and the BNC(f) to Double Banana adapter.

4. Set the HP 3458A to DCV, NPLC = .01, LEVEL 1, TRIG LEVEL.
5. Set the HP 3458A DELAY to .0002 for the top part of the waveform (topline) measurement, and .0007 for the lower part of the waveform (baseline). Manually range lock the HP 3458A to the range that gives the most resolution for the topline measurements. Use this same range for the related baseline measurements at each step.
6. For each calibration step, get samples for 2 seconds minimum, with the HP 3458A MATH functions to retrieve the average or mean value. See the “Setup for SC1100 Edge and Wave Generator Measurements” section to learn more.

### Edge Amplitude Calibration

This procedure uses:

- Hewlett-Packard 3458A Digital Multimeter
- BNC(f) to Double Banana adapter
- Output cable supplied with the SC1100
- 50  $\Omega$  feedthrough termination

To do Edge Amplitude Calibration:

1. Setup the equipment as shown in Figure 7-4.
2. Push the **OPTIONS** softkey.
3. Push the **NEXT SECTION** softkey until “Set up to measure fast edge amplitude” shows in the display.
4. Connect the SCOPE connector of the Calibrator to the HP 3458A input with the output cable and the BNC(f) to Double Banana adapter.
5. Set the HP 3458A to DCV, NPLC = .01, LEVEL 1, TRIG LEVEL.
6. Set the HP 3458A DELAY to .0002 for the top part of the waveform (topline) measurement, and .0007 for the lower part of the waveform (baseline). Manually range lock the HP 3458A to the range that gives the most resolution for the baseline measurements. Use this same range for the related baseline measurements at each step.

#### Note

*For the edge function, the topline is near 0 V and the baseline is a negative voltage.*

7. For each calibration step, get samples for 2 seconds minimum, with the HP 3458A MATH functions to retrieve the average or mean value. See the “Setup for SC1100 Edge and Wave Generator Measurements” section to learn more.

The “true amplitude” of the waveform is the difference between the topline and baseline measurements, after a load resistance error correction. To make this correction, multiply the measurement by  $(0.5 * (50 + Rload)/Rload)$ , where Rload = actual feedthrough termination resistance.

### Leveled Sine Wave Amplitude Calibration

This procedure uses:

- 5790A AC Measurement Standard
- BNC(f) to Double Banana adapter
- Output cable supplied with the SC1100
- 50  $\Omega$  feedthrough termination

To do a leveled sine wave amplitude calibration:

1. Push the **OPTIONS** softkey.
2. Push the **NEXT SECTION** softkey until “Set up to measure fast edge amplitude” shows in the display.
3. Connect the output cable to the 50 Ω feedthrough termination.
4. Connect the other end of the output cable to the SCOPE connector of the Calibrator.
5. Connect the 50 Ω feedthrough termination at the other end of the cable to input 2 of the 5790A with the BNC(f) to Double Banana adapter.
6. Set the 5790A to AUTORANGE, digital filter mode to FAST, restart fine, and Hi Res on.
7. Push the **GO ON** softkey on the Calibrator.
8. Push **OPR** to turn on the Calibrator output.
9. Let the 5790A rms measurement become stable.
10. Multiply the 5790A measurement by  $(0.5 * (50 + R_{load})/R_{load})$ , where  $R_{load}$  = the actual feedthrough termination resistance, to correct for the resistance error. Type in the corrected rms measurement through the keypad of the Calibrator.
11. Push **ENTER**.

*Note*

*The Calibrator will show a message if the typed in value is higher or lower than the limits of the value. If this occurs, examine the setup and carefully re-type in the measurement with the correct multiplier (m, μ, n, p). If the warning continues, repair may be necessary.*

12. Do step 10 and 11 again until the Calibrator shows that the subsequent steps calibrate Leveled Sine flatness. Push the **OPTIONS**, then **STORE CONSTS** softkeys to store the new calibration constants.

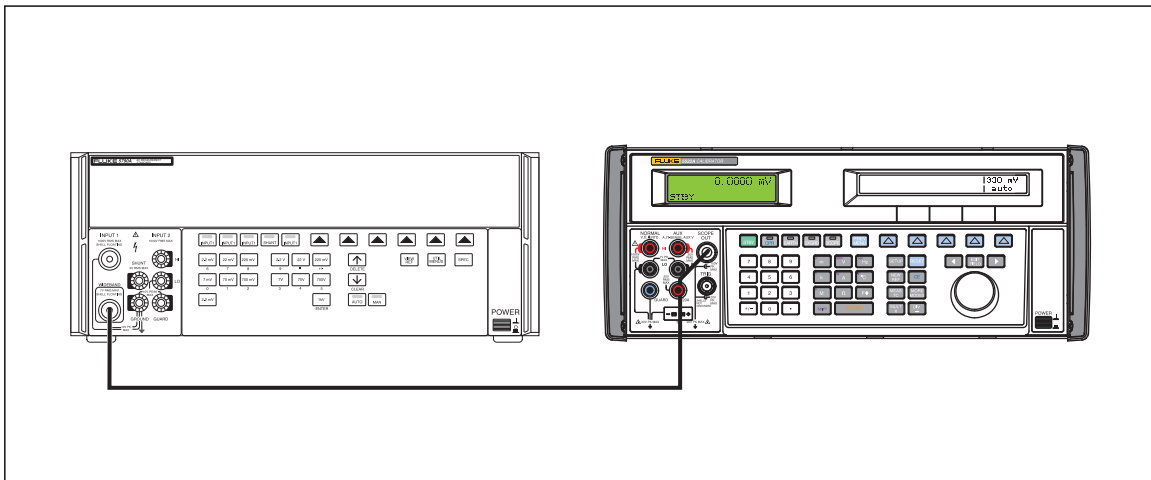

**Figure 7-5. Calibrator to 5790A AC Measurement Standard Connections**

gjh103.eps

**Leveled Sine Wave Flatness Calibration**

Leveled Sine Wave flatness calibration is divided into two frequency bands: 50 kHz to 10 MHz (low frequency) and >10 MHz to 600 MHz (high frequency). The equipment setups are different for each band. Flatness calibration of the low frequency band is made

relative to 50 kHz. Flatness calibration of the high frequency band is made relative to 10 MHz.

Leveled Sine Wave flatness is calibrated at multiple amplitudes. The low and high frequency bands are calibrated at each amplitude. Calibration starts with the low frequency band, then the high frequency band for the first amplitude, followed by the low frequency band, then the high frequency band for the second amplitude, and so on, until the flatness calibration is complete.

Push the **OPTIONS** and **NEXT SECTION** softkeys until “Set up to measure leveled sine flatness” shows in the display.

### *Low Frequency Calibration*

To do the low frequency calibration:

1. Connect the SCOPE connector of the Calibrator to the wideband input of the 5790A. See the “Equipment Setup for Low Frequency Flatness” section to learn more.
2. Push the **GO ON** softkey.
3. Find the 50 kHz reference.
  - Let the 5790A measurement become stable.
  - Push the 5790A **Set Ref** softkey.
4. Push the 5790A **Clear Ref** softkey to clear the reference if necessary.
5. Push the **GO ON** softkey.
6. Adjust the amplitude with the front panel knob of the Calibrator until the 5790A reference deviation equals the 50 kHz reference  $\pm 1000$  ppm.
7. Do steps 2 through 6 again until Calibrator shows that the reference frequency is 10 MHz.

Continue with the high frequency calibration.

### *High Frequency Calibration*

To do the high frequency calibration:

1. Connect the SCOPE connector of the Calibrator to the power meter and power sensor. See the “Equipment Setup for High Frequency Flatness” section to learn more.
2. Push the **GO ON** softkey.
3. Find the 10 MHz reference.
  - Push the power meter **SHIFT Key**, then **FREQ** key and use the arrow keys to type in the cal factor of the power sensor. Make sure the factor is correct, then push the **ENTER** key on the power meter.
  - Let the power meter measurement become stable.
  - Push the power meter **REL** key.
4. Push the **GO ON** softkey.
5. Push the power meter **SHIFT key**, then **FREQ** key, and use the arrow keys to set the Cal Factor of the power sensor for the frequency shown in the Calibrator display. Make sure that the factor is correct, then push the power meter **ENTER** key.
6. Adjust the amplitude with the front panel knob of the Calibrator until the power sensor is equal to the 10 MHz reference  $\pm 0.1$  %.

7. Do steps 1 through 5 again until the Calibrator display shows that the reference frequency is now 50 kHz or that the subsequent step is calibrate pulse width.

Do the low frequency calibration procedure for the subsequent amplitude unless the Calibrator Mainframe display shows that the subsequent steps calibrate pulse width. Push the **OPTIONS**, then **STORE CONSTS** softkeys to store the new calibration constants.

### **Pulse Width Calibration**

This procedure uses:

- High Frequency Digital Storage Oscilloscope (DSO): Tektronix 11801 with Tektronix SD-22/26 sampling head
- 3 dB attenuator, 3.5 mm (m/f)
- BNC(f) to 3.5 mm(m) adapter (2)
- Output cable supplied with the SC1100
- Second BNC cable

To do a pulse width calibration:

1. Push the **OPTIONS** softkey.
2. Push the **NEXT SECTION** softkey until “Set up to measure pulse width” shows in the display.
3. Connect the output cable to the SCOPE connector on the Calibrator. Connect the other end of the output cable to one of the BNC(f) to 3.5 mm (m) adapter and then to the sampling head of the DSO through the 3 dB attenuator.
4. Use the second BNC cable with the BNC(f) to 3.5 mm(m) adapter attached to connect the TRIG OUT of the Calibrator to the trigger input of the DSO.
5. Set the DSO to:
  - Main Time Base: 40 ns
  - Vertical scale: 200 mV/div, +900 mV offset
  - Trigger: source = ext, level = 0.5 V, ext.  
atten. = x10, slope = +, mode = auto
  - Measurement function: positive width
6. Push the **GO ON** softkey.
7. Adjust the DSO horizontal scale and main time base position until the pulse signal spans between half and full display. If no pulse is output, increase the pulse width with the front-panel knob of the Calibrator until a pulse is output.
8. If instructed to adjust the pulse width by the Calibrator display, adjust the pulse width to as near 4 ns as possible with the front-panel knob of the Calibrator.
9. Push the **GO ON** softkey.
10. Let the DSO width measurement become stable.
11. Type in the measurement through the keypad of the Calibrator
12. Push .

*Note*

*The Calibrator shows a message if the typed in value is higher or lower than the limits of the value. If this occurs, examine the setup and carefully re-type in the measurement with the correct multiplier ( $m, \mu, n, p$ ). If the warning continues, type in a value between the pulse width shown in the display and the last typed in value. Continue to do this with a value that is nearer to the pulse width in the display until the value is accepted. After you complete the pulse width calibration you must re do the calibration until all typed in values are accepted the first time without the message.*

13. Do steps 7 through 12 again until the Calibrator instructs you to connect a resistor.
14. Push the **OPTIONS**, then **STORE CONSTS** softkeys to store the new calibration constants.

### **MeasZ Calibration**

The MeasZ function is calibrated with resistors and a capacitor of known values. The actual resistance and capacitance values are typed in while they are measured by the Calibrator.

The resistors and capacitor must make a solid connection to a BNC(f) to make a connection to the end of the BNC cable supplied with the SC1100. The resistance and capacitance values must be known at this BNC(f) connector. An HP 3458A DMM is used to make a 4-wire ohms measurement at the BNC(f) connector to find the actual resistance values. An HP 4192A Impedance Analyzer at 10 MHz is used to find the actual capacitance value.

This procedure uses:

- Resistors of known values: 1 M $\Omega$  and 50  $\Omega$  nominal
- Adapters to connect resistors to the BNC(f) connector
- Adapters and capacitor to get 50 pF nominal value at the end of the BNC(f) connector
- Output cable supplied with the SC1100

To do a MeasZ calibration:

1. Connect the equipment as shown in Figure 7-6.

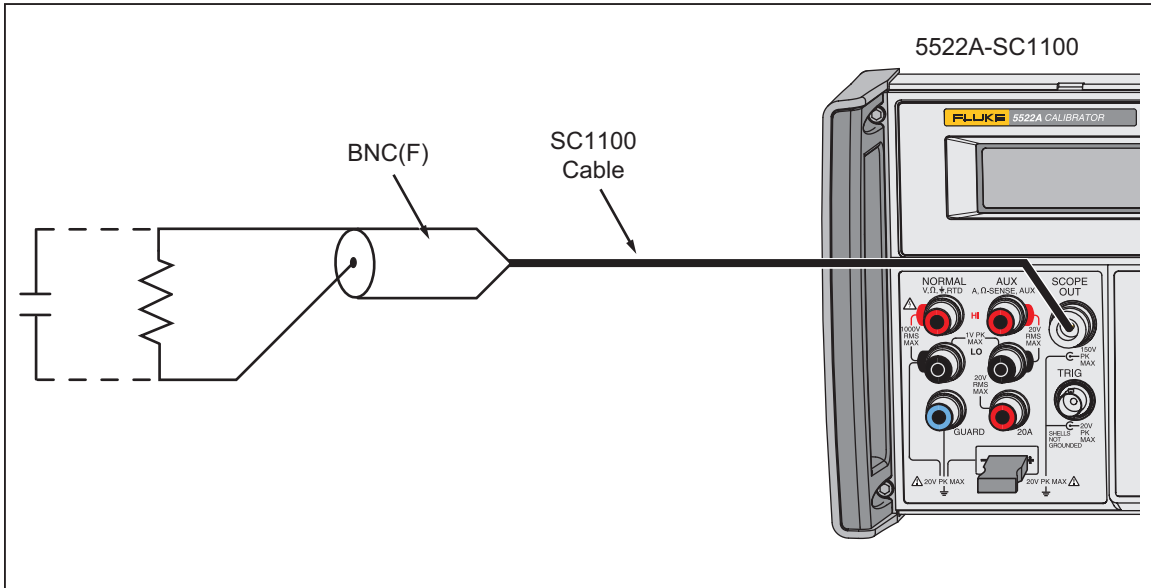

**Figure 7-6. MeasZ Calibration Connections**

gjh136.eps

2. Push the **OPTIONS** softkey.
3. Push the **NEXT SECTION** softkey until “connect a 50 Ω resistor” shows in the display.
4. Connect the output cable to the SCOPE connector of the Calibrator.
5. Connect the other end of the output cable to BNC(f) connector attached to the 50 Ω resistor.
6. Push the **GO ON** softkey.
7. Type in the 50 Ω resistance.

*Note*

*The Calibrator will show a message if the typed in value is higher or lower than the limits of the value. If this occurs, examine the setup and carefully re-type in the measurement with the correct multiplier (m, μ, n, p). If the warning continues, repair may be necessary.*

8. When instructed by the Calibrator, disconnect the 50 Ω resistance and connect the 1 MΩ resistance to the end of the output cable.
9. Push the **GO ON** softkey.
10. Type in the actual 1 MΩ resistance.
11. When instructed for the first reference capacitor by the Calibrator, disconnect the 1 MΩ resistance and leave nothing attached to the end of the output cable.
12. Push the **GO ON** softkey.
13. Enter 0.
14. When prompted for the second reference capacitor by the Calibrator, connect the 50 pF capacitance to the end of the output cable.
15. Push the **GO ON** blue softkey.
16. Type in the actual 50 pF capacitance.
17. When the Calibrator shows calibration is complete in the display, push the **OPTIONS**, then **STORE CONSTS** softkeys to store the new calibration constants.

## Verification

Do a verification of all Oscilloscope Calibration functions a minimum of one time each year, or when the SC1100 is calibrated. The verification procedures in this section supply traceable results. The factory uses different procedures and instruments of higher precision than those shown in this manual. The procedures in this manual let you verify the SC1100 at your site if necessary. Fluke recommends you send the Calibrator to Fluke for calibration and verification.

All equipment used to do a verification on the SC1100 must be calibrated, certified traceable if traceability is to be kept, and operated in their specified operation environment.

It is also important to make sure that the equipment has had sufficient time to warm up before you start verification. Refer to the operation manual for each piece of equipment for more information.

Before you start verification, look at all of the procedures to make sure you have the resources to do them.

Table 7-4 is a list of the SC1100 functions and verification methods.

**Table 7-4. Verification Methods for SC1100 Functions**

Function	Verification Method
DC Voltage	Procedure supplied in this manual.
AC Voltage amplitude	Procedure supplied in this manual.
AC Voltage frequency	Procedure supplied in this manual.
Edge amplitude	Procedure supplied in this manual.
Edge frequency, duty cycle, rise time	Procedure supplied in this manual.
Tunnel Diode Pulser amplitude	Procedure supplied in this manual. See the "Voltage and Edge Calibration and Verification" section to learn more.
Leveled sine wave amplitude, frequency, harmonics, and flatness	Procedure supplied in this manual.
Time marker period	Procedure supplied in this manual.
Wave generator amplitude	Procedure supplied in this manual.
Pulse width, period	Procedure supplied in this manual.
MeasZ resistance, capacitance	Procedure supplied in this manual.
Overload functionality	Procedure supplied in this manual.

### DC Voltage Verification

This procedure uses:

- Hewlett-Packard 3458A Digital Multimeter
- BNC(f) to Double Banana adapter
- Output cable supplied with the SC1100
- 50  $\Omega$  feedthrough termination

For dc voltage verification, see Figure 7-4 for equipment connections.

Set the Calibrator to SCOPE mode, with the Volt menu shown in the display.

**Verification at 1 MΩ**

To do a 1 MΩ verification:

1. Connect the SCOPE connector of the Calibrator to the HP 3458A input, with the cable and the BNC(f) to Double Banana adapter.
2. Make sure the Calibrator is set to 1 MΩ (The **Output @** softkey toggles the impedance between 50 Ω and 1 MΩ).
3. Set the HP 3458A to DCV, Auto Range, NPLC = 10, FIXEDZ = on.
4. Set the Calibrator output to the voltage in Table 7-5.
5. Push **OPR** on the Calibrator.
6. Let the HP 3458A measurement become stable.
7. Record the HP 3458A measurement for each voltage in Table 7-5.
8. Compare the result to the tolerance column.

**Verification at 50 Ω**

To do a 50 Ω verification:

1. Connect the SCOPE connector of the Calibrator to the HP 3458A input, with the cable and the 50 Ω termination connected to the BNC(f) to Double Banana adapter.
2. Make sure the Calibrator impedance is set to 50 Ω (The **Output @** softkey toggles the impedance between 50 Ω and 1 MΩ).
3. Set the HP 3458A to DCV, Auto Range, NPLC = 10, FIXEDZ = on.
4. Set the Calibrator output to the voltage in Table 7-6.
5. Push **OPR** on the Calibrator.
6. Let the HP 3458A measurement become stable.
7. Record the HP 3458A measurement for each voltage in Table 7-6.
8. Compare the result to the tolerance column.

**Table 7-5. DC Voltage Verification at 1 MΩ**

Calibrator Output	HP 3458A Measurement (V dc)	Tolerance ±(V dc)
0 mV		0.00004 V
1.25 mV		4.063E-05 V
-1.25 mV		4.063E-05 V
2.49 mV		4.125E-05 V
-2.49 mV		4.125E-05 V
2.5 mV		4.125E-05 V
-2.5 mV		4.125E-05 V
6.25 mV		4.313E-05 V
-6.25 mV		4.313E-05 V

Table 7-5. DC Voltage Verification at 1 M $\Omega$  (cont.)

Calibrator Output	HP 3458A Measurement (V dc)	Tolerance $\pm$ (V dc)
9.90 mV		4.495E-05 V
-9.90 mV		4.495E-05 V
10.0 mV		0.000045 V
-10.0 mV		0.000045 V
17.5 mV		4.875E-05 V
-17.5 mV		4.875E-05 V
24.9 mV		5.245E-05 V
-24.9 mV		5.245E-05 V
25.0 mV		0.0000525 V
-25.0 mV		0.0000525 V
67.5 mV		7.375E-05 V
-67.5 mV		7.375E-05 V
109.9 mV		9.495E-05 V
-109.9 mV		9.495E-05 V
110 mV		0.000095 V
-110 mV		0.000095 V
305 mV		0.0001925 V
-305 mV		0.0001925 V
499 mV		0.0002895 V
-499 mV		0.0002895 V
0.50 V		0.00029 V
-0.50 V		0.00029 V
1.35 V		0.000715 V
-1.35 V		0.000715 V
2.19 V		0.001135 V
-2.19 V		0.001135 V
2.20 V		0.00114 V
-2.20 V		0.00114 V
6.60 V		0.00334 V
-6.60 V		0.00334 V
10.99 V		0.005535 V

Table 7-5. DC Voltage Verification at 1 M $\Omega$  (cont.)

Calibrator Output	HP 3458A Measurement (V dc)	Tolerance $\pm$ (V dc)
-10.99 V		0.005535 V
11.0 V		0.00554 V
-11.0 V		0.00554 V
70.5 V		0.03529 V
-70.5 V		0.03529 V
130.0 V		0.06504 V
-130.0 V		0.06504 V

Table 7-6. DC Voltage Verification at 50  $\Omega$

Calibrator Output	HP 3458A Measurement (V dc)	Tolerance (V dc min.)	Tolerance (V dc max.)
0 mV		-0.040 mV	0.040 mV
2.49 mV		2.4438 mV	2.5362 mV
-2.49 mV		-2.5362 mV	-2.4438 mV
9.90 mV		9.835 mV	9.965 mV
-9.90 mV		-9.965 mV	-9.835 mV
24.9 mV		24.798 mV	25.002 mV
-24.9 mV		-25.002 mV	-24.798 mV
109.9 mV		109.585 mV	110.215 mV
-109.9 mV		-110.215 mV	-109.585 mV
499 mV		497.71 mV	500.29 mV
-499 mV		-500.29 mV	-497.71 mV
2.19 V		2.1845 V	2.1955 V
-2.19 V		-2.1955 V	-2.1845 V
6.599 V		6.5825 V	6.6155 V
-6.599 V		-6.6155 V	-6.5825 V

### AC Voltage Amplitude Verification

This procedure uses:

- Hewlett-Packard 3458A Digital Multimeter
- BNC(f) to Double Banana adapter
- Output cable supplied with the SC1100
- 50  $\Omega$  feedthrough termination
- Second BNC cable

For ac voltage verification, see Figure 7-3 for equipment connections.

Set the Calibrator to SCOPE mode, with the Volt menu shown in the display.

### Verification at 1 MΩ

To do a 1 MΩ verification:

1. Connect the SCOPE connector of the Calibrator to the HP 3458A input, with the cable and the BNC(f) to Double Banana adapter.
2. Connect the TRIG OUT connector of the Calibrator to the EXT Trig connector on the rear panel of the HP 3458A.
3. Make sure the Calibrator is set to 1 MΩ (The **Output @** softkey toggles the impedance between 50 Ω and 1 MΩ).
4. For ac voltage output at 1 kHz, set the HP 3458A to DCV, NPLC = .01, TRIG EXT.
5. Set the HP 3458A DELAY to .0007 for the top part of the waveform (topline) measurement, and .0012 for the lower part of the waveform (baseline). Manually range lock the HP 3458A to the range that gives the most resolution for the topline measurements. Use this same range for the related baseline measurements at each step.
6. Push the TRIG softkey on the Calibrator until **I1** shows in the display.
7. Measure the topline first as shown in Table 7-7. For each measurement, get samples for 2 seconds minimum, with the HP 3458A MATH functions to retrieve the average or mean value. See the “Setup for SC1100 Edge and Wave Generator Measurements” section to learn more.
8. Measure the baseline of each output after the topline measurement, as shown in Table 7-7. The peak-to-peak value is the difference between the topline and baseline measurements. Compare the result to the tolerance column.
9. When you make measurements at the other frequencies, set up the HP 3458A (NPLC and topline and baseline DELAY) as shown in Table 7-2. (See the “Setup for SC1100 Voltage Square Wave Measurements” section.)

**Table 7-7. AC Voltage Verification at 1 MΩ**

Calibrator Output (1 kHz, or as noted)	HP 3458A Range	Topline Measurement	Baseline Measurement	Peak-to-Peak	Tolerance (±V)
1 mV	100 mV dc				0.000041
-1 mV	100 mV dc				0.000041
10 mV	100 mV dc				0.00005
-10 mV	100 mV dc				0.00005
25 mV	100 mV dc				0.000065
-25 mV	100 mV dc				0.000065
110 mV	100 mV dc				0.00015
-110 mV	100 mV dc				0.00015
500 mV	1 V dc				0.00054
-500 mV	1 V dc				0.00054
2.2 V	10 V dc				0.00224

Table 7-7. AC Voltage Verification at 1 MΩ (cont.)

Calibrator Output (1 kHz, or as noted)	HP 3458A Range	Topline Measurement	Baseline Measurement	Peak-to-Peak	Tolerance (±V)
-2.2 V	10 V dc				0.00224
11 V	10 V dc				0.01104
-11 V	10 V dc				0.01104
130 V	1000 V dc				0.13004
-130 V	1000 V dc				0.13004
200 mV, 100 Hz	1 V dc				0.00024
200 mV, 1 kHz	1 V dc				0.00024
200 mV, 5 kHz	1 V dc				0.00054
200 mV, 10 kHz	1 V dc				0.00054
2.2 V, 100 Hz	10 V dc				0.00224
2.2 V, 5 kHz	10 V dc				0.00554
2.2 V, 10 kHz	10 V dc				0.00554

**Verification at 50 Ω**

To do a 50 Ω verification:

1. Connect the SCOPE connector of the Calibrator to the HP 3458A input, with the output cable and the 50 Ω termination connected to the BNC(f) to Double Banana adapter.
2. Connect the TRIG OUT connector of the Calibrator to the EXT Trig connector on the rear panel of the HP 3458A.
3. Make sure the Calibrator impedance is set to 50 Ω (The **Output @** softkey toggles the impedance between 50 Ω and 1 MΩ).
4. Set the HP 3458A to DCV, NPLC = .01, TRIG EXT.
5. Set the HP 3458A DELAY to .0007 for the top part of the waveform (topline) measurement, and .0012 for the lower part of the waveform (baseline). Manually range lock the HP 3458A to the range that gives the most resolution for the topline measurements. Use this same range for the related baseline measurements at each step. See Table 7-8.
6. Push the TRIG softkey on the Calibrator until **/1** shows in the display.
7. Measure the topline first as shown in Table 7-8. For each measurement, get samples for 2 seconds minimum, with the HP 3458A MATH functions to retrieve the average or mean value. See the “Setup for SC1100 Edge and Wave Generator Measurements” section to learn more.
8. Measure the baseline of each output after the topline measurement, as shown in Table 7-8. The peak-to-peak value is the difference between the topline and baseline measurements. Compare the result to the tolerance column.

Table 7-8. AC Voltage Verification at 50 Ω

Calibrator Output (1 kHz)	HP 3458A Range	Topline Measurement	Baseline Measurement	Peak-to-Peak	Peak-to-Peak x correction	Tolerance (±V)
1 mV	100 mV dc					0.000043
-1 mV	100 mV dc					0.000043
10 mV	100 mV dc					0.000065
-10 mV	100 mV dc					0.000065
25 mV	100 mV dc					0.000103
-25 mV	100 mV dc					0.000103
110 mV	100 mV dc					0.000315
-110 mV	100 mV dc					0.000315
500 mV	1 V dc					0.00129
-500 mV	1 V dc					0.00129
2.2 V	10 V dc					0.00554
-2.2 V	10 V dc					0.00554
6.6 V	10 V dc					0.01654
-6.6 V	10 V dc					0.01654

**AC Voltage Frequency Verification**

This procedure uses:

- PM 6680 Frequency Counter with an ovenized timebase (Option PM 9690 or PM 9691)
- Output cable supplied with the SC1100

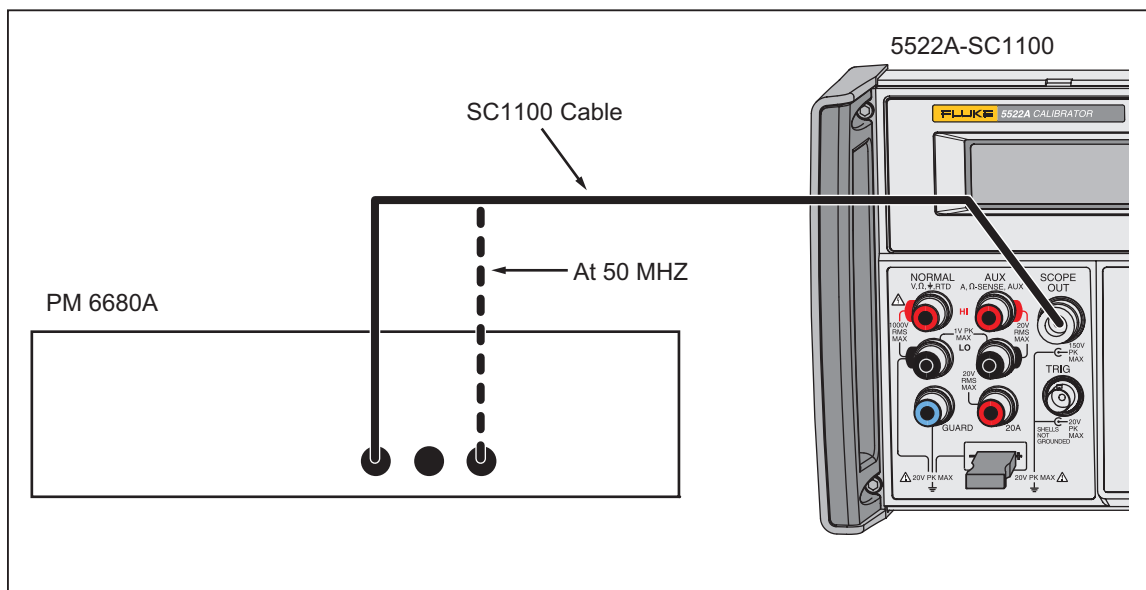

Figure 7-7. AC Voltage Frequency Verification Setup

gjh137.eps

To do an ac voltage frequency verification:

1. Set the Calibrator to SCOPE mode, with the Volt menu shown in the display.
2. Push **OPR** on the Calibrator.
3. Set the FUNCTION of the PM 6680 to measure frequency on channel A with auto trigger, measurement time set to 1 second or longer, 1 MΩ impedance, and filter off.
4. Connect the SCOPE connector on the Calibrator to channel A of the PM 6680 with the output cable. See Figure 7-7.
5. Set the Calibrator to output 2.1 V at each frequency shown in Table 7-9.
6. Let the PM 6680 measurement become stable.
7. Record the PM 6680 measurement for each frequency shown in Table 7-9.
8. Compare to the tolerance column of Table 7-9.

**Table 7-9. AC Voltage Frequency Verification**

Calibrator Frequency	PM 6680 Measurement (Frequency)	Tolerance
10 Hz		0.000025 Hz
100 Hz		0.00025 Hz
1 kHz		0.0025 Hz
10 kHz		0.025 Hz

**Edge Amplitude Verification**

To do an edge amplitude verification:

1. Connect the SCOPE connector of the Calibrator to the HP 3458A input, with the output cable and the 50 Ω termination connected to the BNC(f) to Double Banana adapter.
2. For ac voltage output at 1 kHz, set the HP 3458A to DCV, NPLC = .01, LEVEL 1, TRIG LEVEL. For ac voltage output of 10 kHz, change the NPLC to .001.
3. Set the HP 3458A DELAY to .0002 for the top part of the waveform (topline) measurement, and .0007 for the lower part of the waveform (baseline).
4. Manually range lock the HP 3458A to the range that gives the most resolution for the baseline measurements. Use this same range for the related baseline measurements at each step. See Table 7-10.

*Note*

*For the edge function, the topline is near 0 V and the baseline is a negative voltage.*

5. For each measurement, get samples for 2 seconds minimum, with the HP 3458A MATH functions to retrieve the average or mean value. See the “Setup for SC1100 Edge Wave Generator Measurements” section to learn more.
6. The peak-to-peak value of the waveform is the difference between the topline and baseline measurements. Multiply the measurements by  $(0.5 * (50 + R_{load}) / R_{load})$ , where  $R_{load}$  = the actual feedthrough termination resistance, to correct for the resistance error.
7. Record each measurement in Table 7-10.

Table 7-10. Edge Amplification Verification

Calibrator Edge Output	HP 3458A Range	Topline Measurement	Baseline Measurement	Peak-to-Peak	Peak-to-Peak x correction	Tolerance ( $\pm V$ )
100 mV, 1 kHz	100 mV dc					0.0022
1.00V, 1 kHz	1 V dc					0.0202
5 mV, 10 kHz	100 mV dc					0.0003
10 mV, 10 kHz	100 mV dc					0.0004
25 mV, 10 kHz	100 mV dc					0.0007
50 mV, 10 kHz	100 mV dc					0.0012
100 mV, 10 kHz	1 V dc					0.0022
500 mV, 10 kHz	1 V dc					0.0102
1.00 V, 10 kHz	1 V dc					0.0202
2.5 V, 10 kHz	10 V dc					0.0502

### Edge Frequency Verification

This procedure uses:

- PM 6680 Frequency Counter with an ovenized timebase (Option PM 9690 or PM 9691)
- Output cable supplied with the SC1100

To do an Edge Frequency Verification:

1. Connect the equipment as shown in Figure 7-7.
2. Set the Calibrator to SCOPE mode, with the edge menu shown in the display.
3. Push **OPR** on the Calibrator.
4. Set the FUNCTION of the PM 6680 to measure frequency on channel A with auto trigger, measurement time set to 1 second or longer, 50  $\Omega$  impedance, and filter off.
5. Connect the SCOPE connector on the Calibrator to channel A of the PM 6680 with the output cable.
6. Set the Calibrator to output 2.5 V at each frequency shown in Table 7-11.
7. Let the PM 6680 measurement become stable.
8. Record the PM 6680 measurement for each frequency shown in Table 7-11.
9. Compare to the tolerance column of Table 7-11.

Table 7-11. Edge Frequency Verification

Calibrator Frequency (output @ 2,5 V p-p)	PM 6680 Measurement (Frequency)	Tolerance
1 kHz		0.0025 Hz
10 kHz		0.025 Hz
100 kHz		0.25 Hz

Table 7-11. Edge Frequency Verification (cont.)

Calibrator Frequency (output @ 2,5 V p-p)	PM 6680 Measurement (Frequency)	Tolerance
1 MHz		2.5 Hz
10 MHz		25 Hz

### Edge Duty Cycle Verification

This procedure uses:

- PM 6680 Frequency Counter with an ovenized timebase (Option PM 9690 or PM 9691)
- Output cable supplied with the SC1100

To do an Edge Duty Cycle Verification:

1. Connect the equipment as shown in Figure 7-7.
2. Set the Calibrator to SCOPE mode, with the edge menu shown in the display.
3. Push **OPR** on the Calibrator.
4. Set the FUNCTION of the PM 6680 to measure duty cycle on channel A with auto trigger, measurement time set to 1 second or longer, 50 Ω impedance, and filter off.
5. Connect the SCOPE connector on the Calibrator to channel A of the PM 6680 with the output cable.
6. Set the Calibrator to output 2.5 V at 1 MHz.
7. Let the PM 6680 measurement become stable.
8. Compare to the duty cycle measurement to 50 % ±5 %.

### Edge Rise Time Verification

This verification is a test of the rise time of the edge function. Aberrations are also examined.

This procedure uses:

- High Frequency Digital Storage Oscilloscope: Tektronix 11801 with Tektronix SD-22/26 sampling head
- 3 dB attenuator, 3.5 mm (m/f)
- BNC(f) to 3.5 mm(m) adapter (2)
- Output cable supplied with the SC1100
- BNC-BNC cable

To do an edge rise time verification:

1. Connect the output cable to the SCOPE connector on the Calibrator. Connect the other end of the output cable to one of the BNC(f) to 3.5 mm (m) adapter and then to the sampling head of the DSO through the 3 dB attenuator.
2. Use the second BNC cable with the BNC(f) to 3.5 mm (m) adapter attached to connect the TRIG OUT of the Calibrator to the trigger input of the DSO. See Figure 7-8.

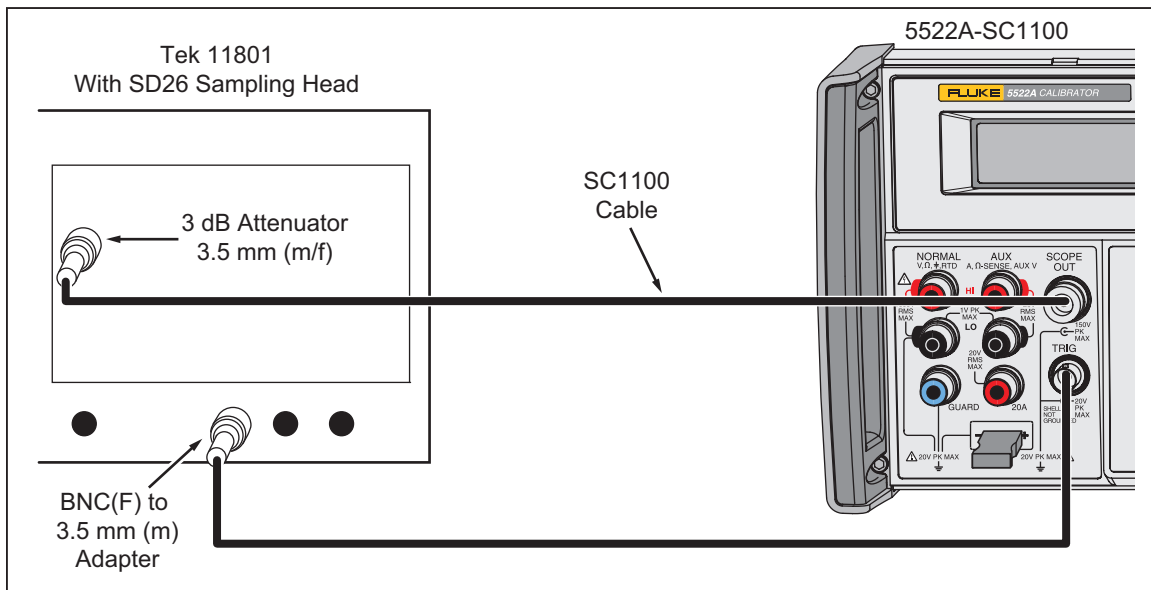

Figure 7-8. Edge Rise Time Verification Setup

gj138/eps

3. Set the Calibrator to SCOPE mode, with the Edge menu shown in the display.
4. Push **OPR** on the Calibrator.
5. Push the TRIG softkey on the Calibrator until **1** shows in the display.
6. Set the Calibrator output to 250 mV @ 1 kHz.
7. Set the DSO to:
  - Main Time Base: 40 ns
  - Horizontal scale: 500 ps/div
  - Measurement function: Rise Time
8. Set the Calibrator to output the voltage and frequency shown in Table 7-12.
9. Push **OPR** on the Calibrator.
10. Change the vertical scale of the DSO to the value shown in Table 7-12.
11. Adjust the main time base position and vertical offset until the edge signal is in the center of the DSO display.
12. Record the rise time measurement in column A of Table 7-12.
13. Correct the rise time measurement for the rise time of the SD-22/26 sampling head. The SD-22/26 rise time is specified as <28 ps.

$$\text{Column B} = \sqrt{(\text{Column A})^2 - (\text{SD-22/26 rise time})^2}$$

14. The measured edge rise time must be less than the time shown in Table 7-12.

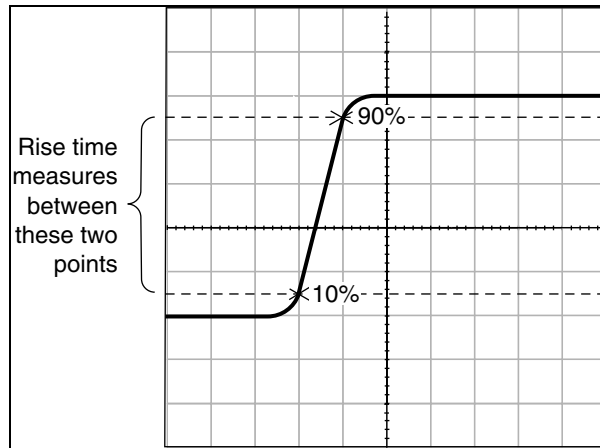

Figure 7-9. Edge Rise Time

om033i.eps

Table 7-12. Edge Rise Time Verification

Calibrator Output		DSO Vertical Axis (mV/div)	A 11801 Measurement	B Corrected Measurement	Tolerance
Voltage	Frequency				
250 mV	1 kHz	20.0			< 300 ps
250 mV	1 MHz	20.0			< 300 ps
250 mV	10 MHz	20.0			< 350 ps
500 mV	1 kHz	50.0			< 300 ps
500 mV	1 MHz	50.0			< 300 ps
500 mV	10 MHz	50.0			< 350 ps
1 V	1 kHz	100.0			< 300 ps
1 V	1 MHz	100.0			< 300 ps
1 V	10 MHz	100.0			< 350 ps
2.5 V	1 kHz	200.0			< 300 ps
2.5 V	1 MHz	200.0			< 300 ps
2.5 V	10 MHz	200.0			< 350 ps

### Edged Aberration Verification

This procedure uses:

- Tektronix 11801 oscilloscope with SC22/26 sampling head
- Output cable supplied with the SC1100

To do edge aberration verification:

1. Make sure that the SC1100 is in the edge mode (the edge menu is shown in the display), and set it to output 1 V p-p @ 1 MHz.
2. Push **OPR**.
3. Connect the Calibrator to the oscilloscope as shown in Figure 7-8.
4. Set the oscilloscope vertical gain to 10 mV/div and horizontal time base to 1 ns/div.
5. Set the oscilloscope to show the 90 % point of the edge signal. Use this point as the reference level.

- Set the oscilloscope to show the first 10 ns of the edge signal with the rising edge at the left edge of the oscilloscope display.

*Note*

*With this setup, each vertical line of the oscilloscope display shows a 1 % aberration.*

- Make sure the SC1100 meets the specifications shown in Table 7-13.

**Table 7-13. Edge Aberrations**

Time from 50 % of Rising Edge	Typical Edge Aberrations
0 - 2 ns	< 32 mV (3.2%)
2 - 5 ns	< 22 mV (2.2%)
5 - 15 ns	< 12 mV (1.2%)
> 15 ns	< 7 mV (0.7%)

**Tunnel Diode Pulser Drive Amplitude Verification**

This procedure uses:

- Hewlett-Packard 3458A Digital Multimeter
- BNC(f) to Double Banana adapter
- Output cable supplied with the SC1100

To do a Diode Pulser Drive Amplitude verification:

- Set the Calibrator to SCOPE mode, with the edge menu shown in the display.
- Connect the SCOPE connector of the Calibrator to the HP 3458A input, with the cable and the BNC(f) to Double Banana adapter. See Figure 7-4.
- Push the **TDPULSE** softkey on the Calibrator.
- Set the output to 80 V peak-to-peak, 100 kHz, STANDBY.
- Set the HP 3458A to DCV, NPLC = .01, LEVEL 1, TRIG LEVEL.
- Set the HP 3458A DELAY to .0012 for the top part of the waveform (topline) measurement, and .0007 for the lower part of the waveform (baseline).
- Manually range lock the HP 3458A to the 100 V range.
- Change the Calibrator Mainframe output frequency to 10 kHz.
- Push **OPR**, and use the HP 3458A to measure the topline and baseline.
- The peak-to-peak value is the difference between the topline and baseline. Record these values in Table 7-14, and compare against the tolerance.

**Table 7-14. Tunnel Diode Pulsar Amplitude Verification**

Calibrator Output	HP 3458A Range	Topline Measurement	Baseline Measurement	Peak-to-Peak	Tolerance (±V)
11	100 V dc				0.2202
11	100 V dc				0.2202
55	100 V dc				1.1002
55	100 V dc				1.1002
100	100 V dc				2.002
100	100 V dc				2.002

**Leveled Sine Wave Amplitude Verification**

This procedure uses:

- 5790A AC Measurement Standard
- BNC(f) to Double Banana Plug adapter
- 50 Ω feedthrough termination
- Output cable supplied with the SC1100

To do a Leveled Sine Wave Amplitude Verification:

1. Connect the equipment as shown in Figure 7-4.
2. Set the Calibrator to SCOPE mode, with the Levsine menu shown in the display.
3. Push **OPR**.
4. Connect the output cable to the 50 Ω feedthrough termination.
5. Connect the one end of the output cable to the SCOPE connector of the Calibrator.
6. Connect the 50 Ω feedthrough termination at the other end of the cable to input 2 of the 5790A with the BNC(f) to Double Banana adapter.
7. Set the 5790A to AUTORANGE, digital filter mode to FAST, restart fine, and Hi Res on.
8. Set the Calibrator to a value shown in column 1 of the Table 7-15.
9. Let the 5790A measurement become stable and then record the 5790A measurement in the table.
10. Multiply the rms measurement by the conversion factor of 2.8284 to get the peak-to-peak value.
11. Multiply the measurements by  $(0.5 * (50 + Rload) / Rload)$ , where Rload = the actual feedthrough termination resistance, to correct for the resistance error.
12. Compare the result to the value in the tolerance column.

Table 7-15. Leveled Sine Wave Amplitude Verification

Calibrator Output (@ 50 kHz)	5790A Measurement (V rms)	5790A Measurement x 2.8284 (V p-p)	V p-p Value x correction	Tolerance (V p-p)
5.0 mV				400 $\mu$ V
7.5 mV				450 $\mu$ V
9.9 mV				498 $\mu$ V
10.0 mV				500 $\mu$ V
25.0 mV				800 $\mu$ V
39.0 mV				1.08 mV
40.0 mV				1.10 mV
70.0 mV				1.70 mV
99.0 mV				2.28 mV
100.0 mV				2.30 mV
250.0 mV				5.30 mV
399.0 mV				8.28 mV
0.4 V				8.3 mV
0.8 V				16.3 mV
1.2 V				24.3 mV
1.3 V				26.3 V
3.4 V				68.3 mV
5.5 V				110.3 mV

### Leveled Sine Wave Frequency Verification

This procedure uses:

- PM 6680 Frequency Counter with a prescaler for the Channel C input (Option PM 9621, PM 9624, or PM 9625) and ovenized timebase (Option PM 9690 or PM 9691)
- BNC(f) to Type N(m) adapter
- Output cable supplied with the SC1100

To do a leveled sine wave frequency verification:

1. Connect the equipment as shown in Figure 7-7.
2. Set the Calibrator to SCOPE mode, with the Levsine menu shown in the display.
3. Set the PM 6680 to the measure frequency function with auto trigger, measurement time set to 1 second or longer, and 50  $\Omega$  impedance.
4. Connect one end of the output cable to the SCOPE connector of the Calibrator.
5. Connect the BNC(f) to Type N(m) adapter to the other end of the output cable.
6. Connect the Type N connector to the PM 6680 channel shown in Table 7-16.
7. Set the filter on the PM 6680 as shown in Table 7-16.
8. Set the Calibrator output to the parameters shown in Table 7-16.
9. Push **OPR**.
10. Let the PM 6680 measurement become stable and then record the frequency measurement in Table 7-16.

Table 7-16. Leveled Sine Wave Frequency Verification

Calibrator Frequency (@ 5.5 V p-p)	PM 6680 Settings		PM 6680 Measurement (Frequency)	Tolerance
	Channel	Filter		
50 kHz	A	On		0.125 Hz
500 kHz	A	Off		1.25 Hz
5 MHz	A	Off		12.5 Hz
50 MHz	A	Off		125 Hz
500 MHz	C	Off		1250 Hz

**Leveled Sine Wave Harmonics Verification**

This procedure uses:

- Hewlett-Packard 8590A Spectrum Analyzer
- BNC(f) to Type N(m) adapter
- Output cable supplied with the SC1100

To do a Leveled Sine Wave Harmonics Verification:

1. Connect the equipment as shown in Figure 7-10.

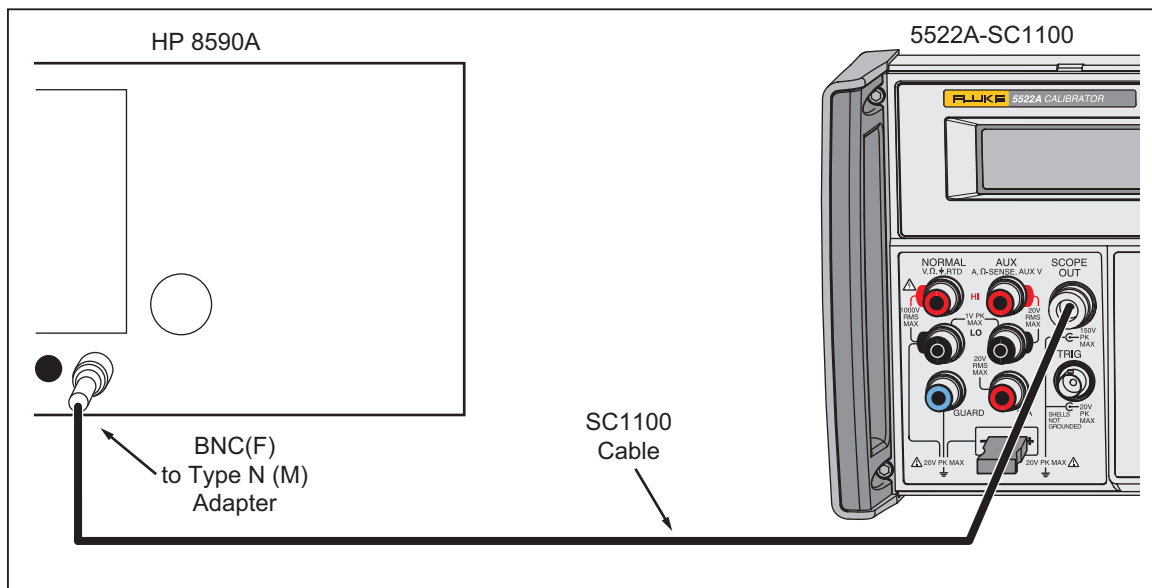

Figure 7-10. Leveled Sine Wave Harmonics Verification Setup

gjh139.eps

2. Set the Calibrator to Scope mode with the Levsine menu shown in the display.
3. Connect one end of the output cable to the SCOPE connector of the Calibrator.
4. Connect the BNC(f) to Type N(m) adapter to the other end of the output cable.
5. Connect the Type N connector to the HP 8590A.
6. Set the Calibrator to output 5.5 V p-p at each frequency on Table 7-17.
7. Push **OPR**.
8. Set the HP 8590A start frequency to the Calibrator output frequency.

9. Set the HP 8590A stop frequency to 10 times the Calibrator output frequency.
10. Set the HP 8590A reference level at +19 dBm.
11. Record the harmonic level measurement for each frequency and harmonic shown in Table 7-17. For harmonics 3, 4, and 5, record the highest harmonic level of the three measured. Harmonics must be below the levels listed in the tolerance column of Table 7-17.

**Table 7-17. Leveled Sine Wave Harmonics Verification**

Calibrator Output Frequency (@ 5.5 V p-p)	Harmonic	HP 8590A Measurement (dB)	Tolerance
50 kHz	2		-33 dB
50 kHz	3, 4, 5		-38 dB
100 kHz	2		-33 dB
100 kHz	3, 4, 5		-38 dB
200 kHz	2		-33 dB
200 kHz	3, 4, 5		-38 dB
400 kHz	2		-33 dB
400 kHz	3, 4, 5		-38 dB
800 kHz	2		-33 dB
800 kHz	3, 4, 5		-38 dB
1 MHz	2		-33 dB
1 MHz	3, 4, 5		-38 dB
2 MHz	2		-33 dB
2 MHz	3, 4, 5		-38 dB
4 MHz	2		-33 dB
4 MHz	3, 4, 5		-38 dB
8 MHz	2		-33 dB
8 MHz	3, 4, 5		-38 dB
10 MHz	2		-33 dB
10 MHz	3, 4, 5		-38 dB
20 MHz	2		-33 dB
20 MHz	3, 4, 5		-38 dB
40 MHz	2		-33 dB
40 MHz	3, 4, 5		-38 dB
80 MHz	2		-33 dB
80 MHz	3, 4, 5		-38 dB

Table 7-17. Leveled Sine Wave Harmonics Verification (cont.)

Calibrator Output Frequency (@ 5.5 V p-p)	Harmonic	HP 8590A Measurement (dB)	Tolerance
100 MHz	2		-33 dB
100 MHz	3, 4, 5		-38 dB
200 MHz	2		-33 dB
200 MHz	3, 4, 5		-38 dB
400 MHz	2		-33 dB
400 MHz	3, 4, 5		-38 dB
600 MHz	2		-33 dB
600 MHz	3, 4, 5		-38 dB
1000 MHz @ 3,5 V	2		-33 dB
1000 MHz @ 3,5 V	3, 4, 5		-39 dB

**Leveled Sine Wave Flatness Verification**

Leveled Sine Wave flatness verification is divided into two frequency bands: 50 kHz to 10 MHz (low frequency) and >10 MHz to 1.1 GHz (high frequency). The equipment setups are different for each band. Leveled Sine Wave flatness is measured relative to 50 kHz. This is a direct measurement in the low frequency band. You must do a “transfer” measurement at 10 MHz in the high frequency band to calculate a flatness relative to 50 kHz.

**Equipment Setup for Low Frequency Flatness**

All low frequency flatness procedures use:

- 5790A/03 AC Measurement Standard with Wideband option
  - BNC(f) to Type N(m) adapter
  - Output cable supplied with the SC1100
1. Connect one end of the output cable to the SCOPE connector of the Calibrator.
  2. Connect the BNC(f) to Type N(m) adapter to the other end of the output cable.
  3. Connect the Type N connector to the HP 5790A WIDEBANC input. See Figure 7-11.
  4. Set the HP 5790A to AUTORANGE, digital filter mode to FAST, restart fine, and Hi Res on.

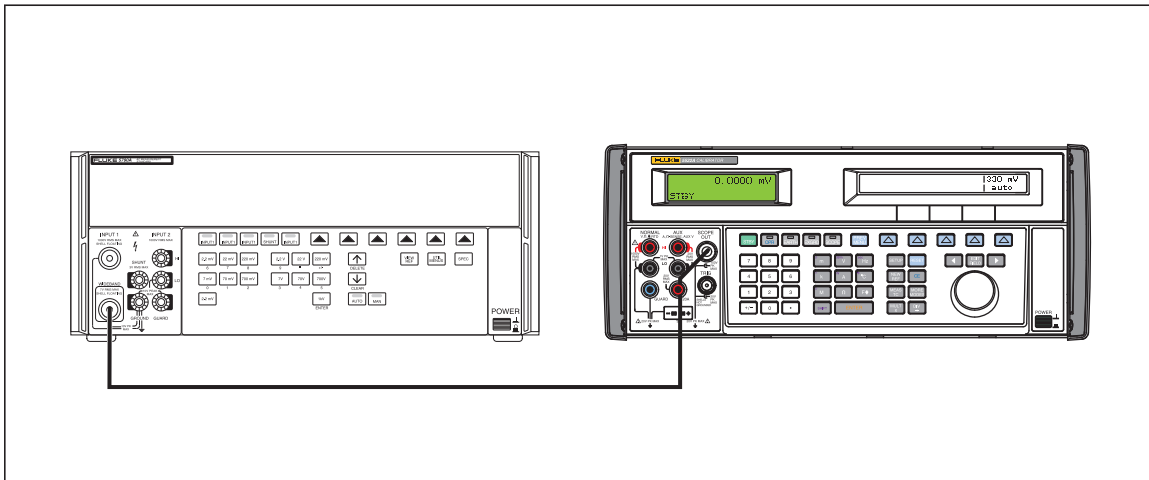

Figure 7-11. Calibrator to 5790A Measurement Standard Connections

gjh103.eps

### Equipment Setup for High Frequency Flatness

All high frequency flatness procedures use:

- Hewlett-Packard 437B Power Meter
- Hewlett-Packard 8482A and 8481D Power Sensors
- BNC(f) to Type N(f) adapter
- Output cable supplied with the SC1100

#### Note

*When high frequencies at voltages less than 63 mV p-p are verified, use the 8481D Power Sensor. For voltages 63 mV p-p and higher, use the 8482A Power Sensor.*

Connect the HP 437B Power Meter to the 8482A or the 8481D Power Sensor as shown in Figure 7-12. To learn more about how to connect these two instruments, refer to the operator manuals of the instruments.

Connect the power meter/power sensor combination to the SCOPE connector on the Calibrator. See Figure 7-13.

The HP 437B Power Meter must be configured with:

- PRESET
- RESOLN 3
- AUTO FILTER
- WATTS
- SENSOR TABLE 0 (default)

Zero and self-calibrate the power meter with the power sensor. Refer to the HP 437B operators manual to learn more.

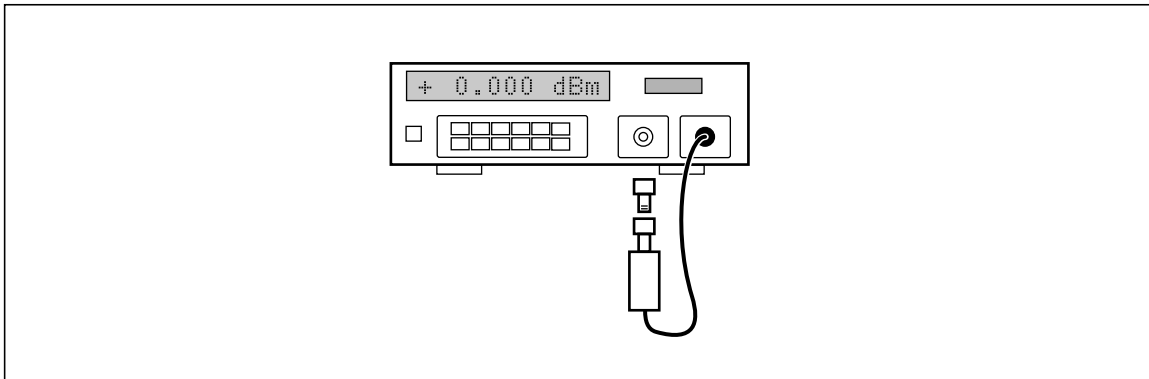

Figure 7-12. HP 437B Power Meter to the HP 8482A or 8481D Power Sensor Connections

om035f.eps

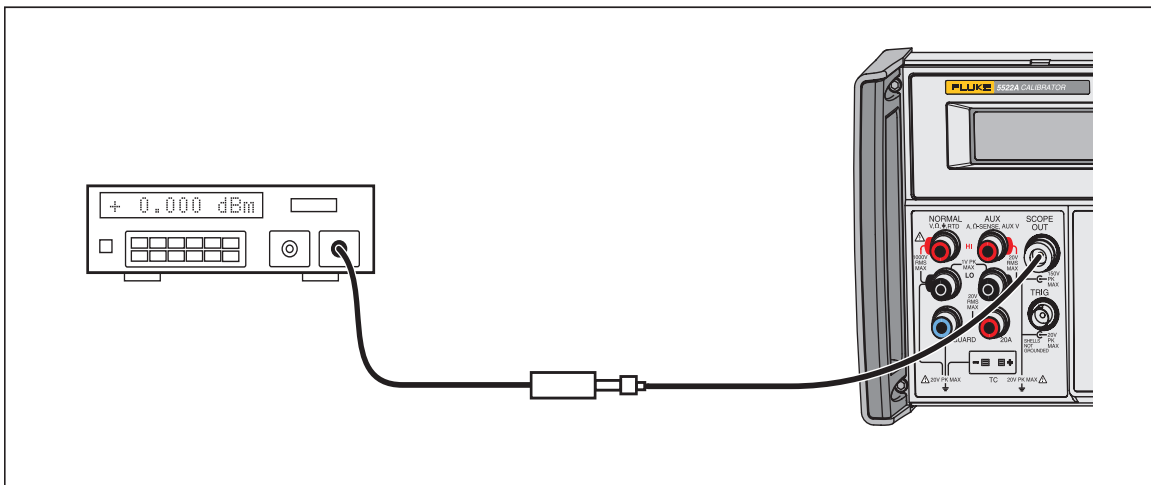

Figure 7-13. Calibrator to the HP Power Meter and Power Sensor Connections

gjh104.eps

### Low Frequency Verification

This procedure gives an example of a low frequency flatness test with a 5.5 V Calibrator output. Use the same procedure for other amplitudes. Compare the results with the flatness specification shown in Table 7-18.

1. Set the Calibrator to output of 5.5 V @ 500 kHz.
2. Push **OPR**.
3. Let the 5790A measurement become stable. The 5790A should display approximately 1.94 V rms.
4. Record the 5790A measurement in column A of Table 7-18.

5. Set the Calibrator frequency to 50 kHz.
6. Let the 5790A measurement become stable and then record the 5790A measurement in column B of Table 7-18.
7. Set the Calibrator to the next frequency shown in Table 7-18.
8. Let the 5790A measurement become stable and then record the measurement in column A of Table 7-18.
9. Set the Calibrator frequency to 50 kHz.
10. Let the 5790A measurement become stable and then record the 5790A measurement in column B of Table 7-18.
11. Do steps 7 through 10 again for all the frequencies shown in Table 7-18. Continue until you have completed Columns A and B.

After you fill in columns A and B for all rows of the table, push **[STBY]**. Use the recorded values in columns A and B to calculate and record the value in column C for all rows.

$$\text{Column C} = 100 \left( \frac{\text{Column A} - \text{Column B}}{\text{Column B}} \right)$$

Compare column C to the specifications shown in the last column.

**Table 7-18. Low Frequency Flatness Verification at 5.5 V**

Calibrator Frequency	A	B 50 kHz	C	Calibrator Flatness Specification (%)
500 kHz				±1.50
1 MHz				±1.50
2 MHz				±1.50
5 MHz				±1.50
10 MHz				±1.50
Fill in Columns A through C as follows: A Record 5790A measurement (mV) for the present frequency. B Record 5790A measurement (mV) for 50 kHz. C Compute and record the Calibrator Flatness deviation (%): $100 * ((\text{Column A}) - (\text{Column B}) / \text{Column B})$ .				

### High Frequency Verification

This procedure gives an example of a high frequency flatness test with a 5.5 V Calibrator output. Use the same procedure for other amplitudes. Compare the results with the flatness specification shown in Table 7-19. For this voltage range, use the HP 8482A Power Sensor.

1. Set the Calibrator to output of 5.5 V @ 30 MHz.
2. Push **[OPR]**.
3. Let the power meter measurement become stable. The power meter measurement should be approximately 75 mW.
4. Record the power meter measurement in column A of Table 7-19.
5. Set the Calibrator frequency to 10 MHz.
6. Let the power meter measurement become stable and then record the measurement in column B of Table 7-19.
7. Set the Calibrator to the next frequency shown in Table 7-19.

8. Let the power meter measurement become stable and then record the measurement in column A of Table 7-19.
9. Set the Calibrator frequency to 10 MHz.
10. Let the power meter measurement become stable and then record the measurement in column B of Table 7-19.
11. Do steps 7 through 10 again for all the frequencies shown in Table 7-19. Continue until you have completed Columns A and B.

When you have filled in columns A and B for all rows of the table, push . Use the recorded values in columns A and B to calculate and record the value in column C for all rows.

Table 7-19. High Frequency Flatness Verification

Amplitude (v)	Calibrator Frequency (MHz)	A	B (10 MHz)	C	D	E	Calibrator Flatness Specification (%)
0.005	50 MHz						±1.50
	100 MHz						±1.50
	150 MHz						±2.00
	200 MHz						±2.00
	250 MHz						±2.00
	300 MHz						±2.00
	350 MHz						±3.50
	400 MHz						±3.50
	450 MHz						±3.50
	500 MHz						±3.50
	550 MHz						±4.00
	600 MHz						±4.00
	1000 MHz						±5.00
0.0075	50 MHz						±1.50
	100 MHz						±1.50
	150 MHz						±2.00
	200 MHz						±2.00
	250 MHz						±2.00
	300 MHz						±2.00
	350 MHz						±3.50
	400 MHz						±3.50
	450 MHz						±3.50
	500 MHz						±3.50
	550 MHz						±4.00
	600 MHz						±4.00
	1000 MHz						±5.00
Fill in Columns A through G as follows: A Record the 437B present frequency measurement (W). B Record the 437B 10 MHz measurement (W). C Apply power sensor correction factor for present frequency (W): CF * (Column A entry). D Apply power sensor correction factor for 10 MHz (W). CF * (Column B entry) E Calculate and record error relative to 10 MHz (%):							

Table 7-19. High Frequency Flatness Verification (cont.)

Amplitude (v)	Calibrator Frequency (MHz)	A	B (10 MHz)	C	D	E	Calibrator Flatness Specification (%)
0.099	50 MHz						±1.50
	100 MHz						±1.50
	150 MHz						±2.00
	200 MHz						±2.00
	250 MHz						±2.00
	300 MHz						±2.00
	350 MHz						±3.50
	400 MHz						±3.50
	450 MHz						±3.50
	500 MHz						±3.50
	550 MHz						±4.00
	600 MHz						±4.00
	1000 MHz						±5.00
	0.01	50 MHz					
100 MHz							±1.50
150 MHz							±2.00
200 MHz							±2.00
250 MHz							±2.00
300 MHz							±2.00
350 MHz							±3.50
400 MHz							±3.50
450 MHz							±3.50
500 MHz							±3.50
550 MHz							±4.00
600 MHz							±4.00
1000 MHz							±5.00
Fill in Columns A through E as follows: A Record the 437B present frequency measurement (W). B Record the 437B 10 MHz measurement (W). C Apply power sensor correction factor for present frequency (W): CF * (Column A entry). D Apply power sensor correction factor for 10 MHz (W). CF * (Column B entry) E Calculate and record error relative to 10 MHz (%):							

Table 7-19. High Frequency Flatness Verification (cont.)

Amplitude (v)	Calibrator Frequency (MHz)	A	B (10 MHz)	C	D	E	Calibrator Flatness Specification (%)
0.025	50 MHz						±1.50
	100 MHz						±1.50
	150 MHz						±2.00
	200 MHz						±2.00
	250 MHz						±2.00
	300 MHz						±2.00
	350 MHz						±3.50
	400 MHz						±3.50
	450 MHz						±3.50
	500 MHz						±3.50
	550 MHz						±4.00
	600 MHz						±4.00
	1000 MHz						±5.00
0.039	50 MHz						±1.50
	100 MHz						±1.50
	150 MHz						±2.00
	200 MHz						±2.00
	250 MHz						±2.00
	300 MHz						±2.00
	350 MHz						±3.50
	400 MHz						±3.50
	450 MHz						±3.50
	500 MHz						±3.50
	550 MHz						±4.00
	600 MHz						±4.00
	1000 MHz						±5.00
Fill in Columns A through E as follows: A Record the 437B present frequency measurement (W). B Record the 437B 10 MHz measurement (W). C Apply power sensor correction factor for present frequency (W): CF * (Column A entry). D Apply power sensor correction factor for 10 MHz (W). CF * (Column B entry) E Calculate and record error relative to 10 MHz (%):							

**Table 7-19. High Frequency Flatness Verification (cont.)**

Amplitude (v)	Calibrator Frequency (MHz)	A	B (10 MHz)	C	D	E	Calibrator Flatness Specification (%)
0.04	50 MHz						±1.50
	100 MHz						±1.50
	150 MHz						±2.00
	200 MHz						±2.00
	250 MHz						±2.00
	300 MHz						±2.00
	350 MHz						±3.50
	400 MHz						±3.50
	450 MHz						±3.50
	500 MHz						±3.50
	550 MHz						±4.00
	600 MHz						±4.00
	1000 MHz						±5.00
	0.07	50 MHz					
100 MHz							±1.50
150 MHz							±2.00
200 MHz							±2.00
250 MHz							±2.00
300 MHz							±2.00
350 MHz							±3.50
400 MHz							±3.50
450 MHz							±3.50
500 MHz							±3.50
550 MHz							±4.00
600 MHz							±4.00
1000 MHz							±5.00
Fill in Columns A through E as follows: A Record the 437B present frequency measurement (W). B Record the 437B 10 MHz measurement (W). C Apply power sensor correction factor for present frequency (W): CF * (Column A entry). D Apply power sensor correction factor for 10 MHz (W). CF * (Column B entry) E Calculate and record error relative to 10 MHz (%):							

Table 7-19. High Frequency Flatness Verification (cont.)

Amplitude (v)	Calibrator Frequency (MHz)	A	B (10 MHz)	C	D	E	Calibrator Flatness Specification (%)
0.099	50 MHz						±1.50
	100 MHz						±1.50
	150 MHz						±2.00
	200 MHz						±2.00
	250 MHz						±2.00
	300 MHz						±2.00
	350 MHz						±3.50
	400 MHz						±3.50
	450 MHz						±3.50
	500 MHz						±3.50
	550 MHz						±4.00
	600 MHz						±4.00
	1000 MHz						±5.00
0.01	50 MHz						±1.50
	100 MHz						±1.50
	150 MHz						±2.00
	200 MHz						±2.00
	250 MHz						±2.00
	300 MHz						±2.00
	350 MHz						±3.50
	400 MHz						±3.50
	450 MHz						±3.50
	500 MHz						±3.50
	550 MHz						±4.00
	600 MHz						±4.00
	1000 MHz						±5.00
Fill in Columns A through E as follows: A Record the 437B present frequency measurement (W). B Record the 437B 10 MHz measurement (W). C Apply power sensor correction factor for present frequency (W): CF * (Column A entry). D Apply power sensor correction factor for 10 MHz (W). CF * (Column B entry) E Calculate and record error relative to 10 MHz (%):							

Table 7-19. High Frequency Flatness Verification (cont.)

Amplitude (v)	Calibrator Frequency (MHz)	A	B (10 MHz)	C	D	E	Calibrator Flatness Specification (%)
0.25	50 MHz						±1.50
	100 MHz						±1.50
	150 MHz						±2.00
	200 MHz						±2.00
	250 MHz						±2.00
	300 MHz						±2.00
	350 MHz						±3.50
	400 MHz						±3.50
	450 MHz						±3.50
	500 MHz						±3.50
	550 MHz						±4.00
	600 MHz						±4.00
	1000 MHz						±5.00
	0.399	50 MHz					
100 MHz							±1.50
150 MHz							±2.00
200 MHz							±2.00
250 MHz							±2.00
300 MHz							±2.00
350 MHz							±3.50
400 MHz							±3.50
450 MHz							±3.50
500 MHz							±3.50
550 MHz							±4.00
600 MHz							±4.00
1000 MHz							±5.00
Fill in Columns A through E as follows: A Record the 437B present frequency measurement (W). B Record the 437B 10 MHz measurement (W). C Apply power sensor correction factor for present frequency (W): CF * (Column A entry). D Apply power sensor correction factor for 10 MHz (W). CF * (Column B entry) E Calculate and record error relative to 10 MHz (%):							

Table 7-19. High Frequency Flatness Verification (cont.)

Amplitude (v)	Calibrator Frequency (MHz)	A	B (10 MHz)	C	D	E	Calibrator Flatness Specification (%)
0.4	50 MHz						±1.50
	100 MHz						±1.50
	150 MHz						±2.00
	200 MHz						±2.00
	250 MHz						±2.00
	300 MHz						±2.00
	350 MHz						±3.50
	400 MHz						±3.50
	450 MHz						±3.50
	500 MHz						±3.50
	550 MHz						±4.00
	600 MHz						±4.00
	1000 MHz						±5.00
0.8	50 MHz						±1.50
	100 MHz						±1.50
	150 MHz						±2.00
	200 MHz						±2.00
	250 MHz						±2.00
	300 MHz						±2.00
	350 MHz						±3.50
	400 MHz						±3.50
	450 MHz						±3.50
	500 MHz						±3.50
	550 MHz						±4.00
	600 MHz						±4.00
	1000 MHz						±5.00
Fill in Columns A through E as follows: A Record the 437B present frequency measurement (W). B Record the 437B 10 MHz measurement (W). C Apply power sensor correction factor for present frequency (W): CF * (Column A entry). D Apply power sensor correction factor for 10 MHz (W). CF * (Column B entry) E Calculate and record error relative to 10 MHz (%):							

Table 7-19. High Frequency Flatness Verification (cont.)

Amplitude (v)	Calibrator Frequency (MHz)	A	B (10 MHz)	C	D	E	Calibrator Flatness Specification (%)
1.2	50 MHz						±1.50
	100 MHz						±1.50
	150 MHz						±2.00
	200 MHz						±2.00
	250 MHz						±2.00
	300 MHz						±2.00
	350 MHz						±3.50
	400 MHz						±3.50
	450 MHz						±3.50
	500 MHz						±3.50
	550 MHz						±4.00
	600 MHz						±4.00
	1000 MHz						±5.00
1.3	50 MHz						±1.50
	100 MHz						±1.50
	150 MHz						±2.00
	200 MHz						±2.00
	250 MHz						±2.00
	300 MHz						±2.00
	350 MHz						±3.50
	400 MHz						±3.50
	450 MHz						±3.50
	500 MHz						±3.50
	550 MHz						±4.00
600 MHz						±4.00	
Fill in Columns A through E as follows: A Record the 437B present frequency measurement (W). B Record the 437B 10 MHz measurement (W). C Apply power sensor correction factor for present frequency (W): CF * (Column A entry). D Apply power sensor correction factor for 10 MHz (W). CF * (Column B entry) E Calculate and record error relative to 10 MHz (%):							

Table 7-19. High Frequency Flatness Verification (cont.)

Amplitude (v)	Calibrator Frequency (MHz)	A	B (10 MHz)	C	D	E	Calibrator Flatness Specification (%)
3.4	50 MHz						±1.50
	100 MHz						±1.50
	150 MHz						±2.00
	200 MHz						±2.00
	250 MHz						±2.00
	300 MHz						±2.00
	350 MHz						±3.50
	400 MHz						±3.50
	450 MHz						±3.50
	500 MHz						±3.50
	550 MHz						±4.00
	600 MHz						±4.00
	1000 MHz						±5.00
5.5	50 MHz						±1.50
	100 MHz						±1.50
	150 MHz						±2.00
	200 MHz						±2.00
	250 MHz						±2.00
	300 MHz						±2.00
	350 MHz						±3.50
	400 MHz						±3.50
	450 MHz						±3.50
	500 MHz						±3.50
	550 MHz						±4.00
	600 MHz						±4.00
Fill in Columns A through E as follows: A Record the 437B present frequency measurement (W). B Record the 437B 10 MHz measurement (W). C Apply power sensor correction factor for present frequency (W): CF * (Column A entry). D Apply power sensor correction factor for 10 MHz (W). CF * (Column B entry) E Calculate and record error relative to 10 MHz (%):							

**Time Marker Verification**

This procedure uses:

- PM 6680 Frequency Counter with a prescaler for the Channel C input (Option PM 9621, PM 9624, or PM 9625) and ovenized timebase (Option PM 9690 or PM 9691)
- BNC(f) to Type N(m) adapter
- Output cable supplied with the SC1100

To do a Time Marker Verification:

1. Connect the equipment as shown in Figure 7-7.
2. Set the PM 6680 to the measure frequency function with auto trigger, measurement time set to 1 second or longer, and 50  $\Omega$  impedance.
3. Set the Calibrator to SCOPE mode, with the Marker menu shown in the display.
4. Push **OPR**.
5. Set the Calibrator output to the parameters shown in Table 7-16.
6. Connect one end of the Output cable to the SCOPE connector of the Calibrator.
7. Connect the BNC(f) to Type N(m) adapter to the other end of the output cable.
8. Connect the Type N connector to the PM 6680 channel shown in Table 7-16.
9. Set the filter on the PM 6680 as shown in Table 7-16.
10. Let the PM 6680 measurement become stable and then record the frequency measurement in Table 7-16.
11. Calculate the period of the frequency with  $\text{Period} = 1/\text{frequency}$  and record it on the table.
12. Compare the period value to the value in the tolerance column.

**Table 7-20. Time Marker Verification**

Calibrator Period	PM 6680 Settings		PM 6680 Measurement		Tolerance
	Channel	Filter	Frequency	Period	
5 s	A	On			0.3489454 s
2 s	A	On			0.0582996 s
50.0 ms	A	Off			3.872E-05 s
20.0 ms	A	Off			5E-08 s
10.0 ms	A	Off			2.5E-08 s
100 ns	A	Off			2.5E-13 s
50.0 ns	A	Off			1.25E-13 s
20.0 ns	A	Off			5E-14 s
10.0 ns	A	Off			2.5E-14 s
5.00 ns	A	Off			1.25E-14 s
2.00 ns	C	Off			5E-15 s
1.00 ns	C	Off			2.5E-15 s

### Wave Generator Verification

This procedure uses:

- 5790A AC Measurement Standard
- BNC(f) to Double Banana Plug adapter
- 50  $\Omega$  feedthrough termination
- Output cable supplied with the SC1100

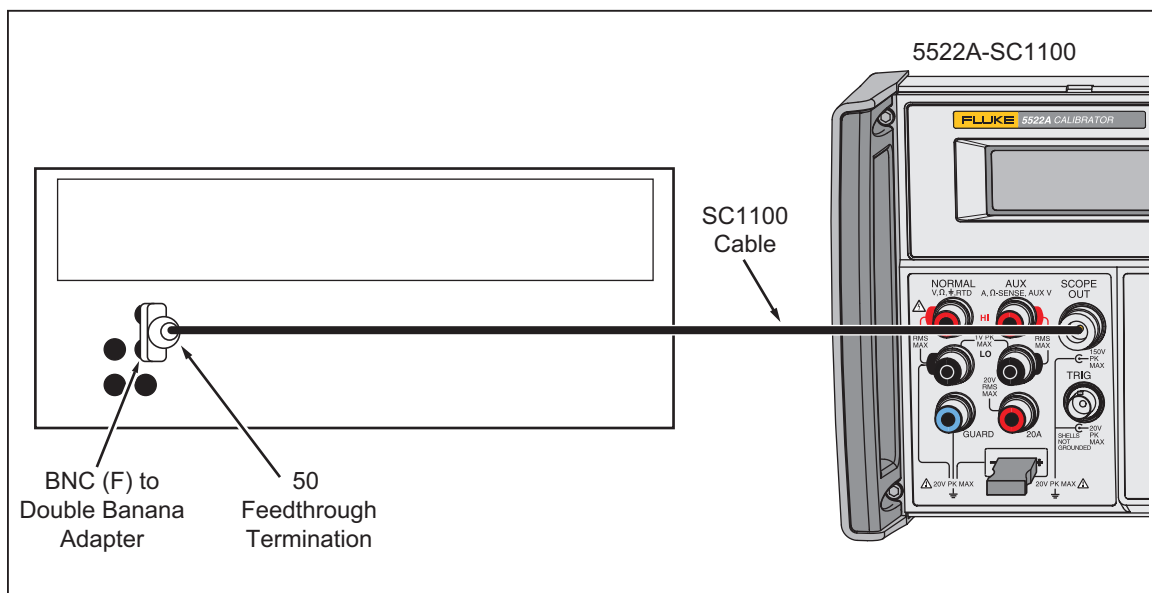

Figure 7-14. Wave Generator Verification Connections

gjh140.eps

Wave Generator Verification is done at two different impedances: 1 M $\Omega$  and 50  $\Omega$ .

### Wave Generator Verification Setup

To setup the equipment for wave generator verification:

1. Connect the equipment as shown in Figure 7-14.
2. Set the Calibrator to SCOPE mode, with the Wavegen menu shown in the display.
3. Push **OPR**.
4. Set offset to 0 mV.
5. Set the Calibrator frequency to 1 kHz.

### Verification at 1 M $\Omega$

1. Set the Calibrator to 1 M $\Omega$ .

*Note*

The **SCOPEZ** softkey toggles the impedance between 50  $\Omega$  and 1 M $\Omega$ .

2. Connect the one end of the output cable to the SCOPE connector of the Calibrator.
3. Connect the other end of the cable to input 2 of the 5790A with the BNC(f) to Double Banana adapter.
4. Set the 5790A to AUTORANGE, digital filter mode to FAST, restart fine, and Hi Res on.
5. Set the Calibrator to output the wave type and voltage shown in Table 7-21.

6. Let the 5790A measurement become stable and then record the 5790A measurement for each wave type and voltage in Table 7-21.
7. Multiply the rms measurement by the conversion factor in Table 7-21 to convert the measurement to a peak-to-peak value.
8. Compare the result to the value in the tolerance column.

**Verification at 50Ω**

1. Set the Calibrator to 50 Ω.

*Note*

*The **SCOPEZ** softkey toggles the impedance between 50 Ω and 1 MΩ.*

2. Connect one end of the output cable to the 50 Ω feedthrough termination.
3. Connect the other end of the output cable to the SCOPE connector of the Calibrator.
4. Connect the 50 Ω feedthrough termination at the other end of the cable to input 2 of the 5790A with the BNC(f) to Double Banana adapter.
5. Set the 5790A to AUTORANGE, digital filter mode to FAST, restart fine, and Hi Res on.
6. Set the Calibrator to output the wave type and voltage shown in Table 7-22.
7. Let the 5790A measurement become stable and then record the 5790A measurement for each wave type and voltage in Table 7-22.
8. Multiply the rms measurement by the conversion factor in Table 7-22 to convert the measurement to a peak-to-peak value.
9. Multiply the peak-to-peak value by  $(0.5 * (50 + Rload) / Rload)$ , where Rload = the actual feedthrough termination resistance, to correct for the resistance error.
10. Compare the result to the value in the tolerance column.

**Table 7-21. Wave Generator Verification at 1 MΩ**

Calibrator Wave Type	Calibrator Output (@ 10 kHz)	5790A Measurement (V rms)	Conversion Factor	5790A Measurement x Conversion Factor (V p-p)	Tolerance (V p-p)
square	1.8 mV		2.0000		0.000154 V
square	11.9 mV		2.0000		0.000457 V
square	21.9 mV		2.0000		0.00075 V
square	22.0 mV		2.0000		0.00076 V
square	56.0 mV		2.0000		0.00178 V
square	89.9 mV		2.0000		0.002797 V
square	90 mV		2.0000		0.0028 V
square	155 mV		2.0000		0.00475 V
square	219 mV		2.0000		0.00667 V
square	220 mV		2.0000		0.0067 V

Table 7-21. Wave Generator Verification at 1 M $\Omega$  (cont.)

Calibrator Wave Type	Calibrator Output (@ 10 kHz)	5790A Measurement (V rms)	Conversion Factor	5790A Measurement x Conversion Factor (V p-p)	Tolerance (V p-p)
square	560 mV		2.0000		0.0169 V
square	899 mV		2.0000		0.02707 V
square	0.90 V		2.0000		0.0271 V
square	3.75 V		2.0000		0.1126 V
square	6.59 V		2.0000		0.1978 V
square	6.6 V		2.0000		0.1981 V
square	30.8 V		2.0000		0.9241 V
square	55.0 V		2.0000		1.6501 V
square	55.0 V @ 10 Hz		2.0		1.6501 V
square	55.0 V @ 100 Hz		2.0		1.6501 V
square	55.0 V @ 10 kHz		2.0		1.6501 V
sine	1.8 mV		2.8284		0.000154 V
sine	21.9 mV		2.8284		0.000757 V
sine	89.9 mV		2.8284		0.002797 V
sine	219 mV		2.8284		0.00667 V
sine	899 mV		2.8284		0.02707 V
sine	6.59 V		2.8284		0.1978 V
sine	55 V		2.8284		1.6501 V
triangle	1.8 mV		3.4641		0.000154 V
triangle	21.9 mV		3.4641		0.000757 V
triangle	89.9 mV		3.4641		0.002797 V
triangle	219 mV		3.4641		0.00667 V
triangle	899 mV		3.4641		0.02707 V
triangle	6.59 V		3.4641		0.1978 V
triangle	55 V		3.4641		1.6501 V

Table 7-22. Wave Generator Verification at 50  $\Omega$

Calibrator Wave Type	Calibrator Output (@ 10 kHz)	5790A Measurement (V rms)	Conversion Factor	5790A Measurement x Conversion Factor (V p-p)	V p-p value x correction	Tolerance (V p-p)
square	1.8 mV		2.0000			0.000154 V
square	6.4 mV		2.0000			0.000292 V
square	10.9 mV		2.0000			0.000427 V
square	11.0 mV		2.0000			0.00043 V
square	28.0 mV		2.0000			0.00094 V
square	44.9 mV		2.0000			0.001447 V
square	45 mV		2.0000			0.00145 V
square	78 mV		2.0000			0.00244 V
square	109 mV		2.0000			0.00337 V
square	110 mV		2.0000			0.0034 V
square	280 mV		2.0000			0.0085 V
square	449 mV		2.0000			0.01357 V
square	450 mV		2.0000			0.0136 V
square	780 mV		2.0000			0.0235 V
square	1.09 V		2.0000			0.0328 V
square	1.10 V		2.0000			0.0331 V
square	1.80 V		2.0000			0.0541 V
square	2.50 V		2.0000			0.0751 V
sine	1.8 mV		2.8284			0.000154 V
sine	10.9 mV		2.8284			0.000427 V
sine	44.9 mV		2.8284			0.001447 V
sine	109 mV		2.8284			0.00337 V
sine	449 mV		2.8284			0.01357 V
sine	1.09 V		2.8284			0.0328 V
sine	2.50 V		2.8284			0.0751 V
triangle	1.8 mV		3.4641			0.000154 V
triangle	10.9 mV		3.4641			0.000427 V
triangle	44.9 mV		3.4641			0.001447 V
triangle	109 mV		3.4641			0.00337 V
triangle	449 mV		3.4641			0.01357 V

Table 7-22. Wave Generation Verification at 50 Ω (cont.)

Calibrator Wave Type	Calibrator Output (@ 10 kHz)	5790A Measurement (V rms)	Conversion Factor	5790A Measurement x Conversion Factor (V p-p)	V p-p value x correction	Tolerance (V p-p)
triangle	1.09 V		3.4641			0.0328 V
triangle	2.50 V		3.4641			0.0751 V

### Pulse Width Verification

This procedure uses:

- High Frequency Digital Storage Oscilloscope: Tektronix 11801 with Tektronix SD-22/26 sampling head
- 3 dB attenuator, 3.5 mm (m/f)
- BNC(f) to 3.5 mm(m) adapter (2)
- Output cable supplied with the SC1100
- Second BNC cable

To do a pulse width verification:

1. Connect the equipment as shown in Figure 7-8.
2. Connect the output cable to the SCOPE connector on the Calibrator. Connect the other end of the output cable to one of the BNC(f) to 3.5 mm (m) adapter and then to the sampling head of the DSO through the 3 dB attenuator.
3. Use the second BNC cable with the BNC(f) to 3.5 mm(m) adapter attached to connect the TRIG OUT of the Calibrator to the trigger input of the DSO.
4. Set the Calibrator to SCOPE mode, with the Edge menu shown in the display.
5. Push **OPR** on the Calibrator.
6. Push the TRIG softkey on the Calibrator until **/1** shows in the display.
7. Set the DSO to:
  - Main Time Base: 40 ns
  - Vertical scale: 200 mV/div
  - Trigger: source = ext, level = 0.5 V, ext. atten. = x10, slope = +, mode = auto
  - Measurement function: positive width
8. Set the Calibrator to the pulse width and period shown in Table 7-23. Set the voltage to 2.5 V.
9. Change the horizontal scale on the DSO to the value shown in Table 7-23.
10. Adjust the main time base position and vertical offset until the pulse signal is in the center of the DSO display.
11. Record the width measurement.
12. Compare the width measurement to the value in the tolerance column of the table.

**Table 7-23. Pulse Width Verification**

Function/Range	Nominal Value	Measured Value	Low Limit	High Limit
2 $\mu$ s Period/4.00 ns	4.000		1.80	6.20
20 $\mu$ s Period/4.00 ns	4.000		1.80	6.20
200 $\mu$ s Period/4.00 ns	4.000		1.80	6.20
2 ms Period/40.00 ns	40.000		36.00	44.00

**Pulse Period Verification**

This procedure uses:

- PM 6680 Frequency Counter with an ovenized timebase (Option PM 9690 or PM 9691)
- Output cable supplied with the SC1100

To do a pulse period verification:

1. Connect the equipment as shown in Figure 7-7.
2. Set the Calibrator to SCOPE mode, with the Pulse menu shown in the display.
3. Push **OPR** on the Calibrator.
4. Set the PM 6680 to the measure period on channel A with auto trigger, measurement time set to 1 second or longer, 50  $\Omega$  impedance, and filter off.
5. Connect one end of the output cable to the SCOPE connector of the Calibrator.
6. Connect the other end of the output cable to the channel A input of the PM 6680.
7. Set the Calibrator to the pulse width and period shown in Table 7-24. Set the voltage to 2.5V.
8. Let the PM 6680 measurement become stable and then record the period measurement in Table 7-24.
9. Compare the result to the tolerance column.

**Table 7-24. Pulse Period Verification**

Function/Range	Nominal Value	Measured Value	Low Limit	High Limit
2 $\mu$ s Period/4.00 ns	4.000		1.80	6.20
20 $\mu$ s Period/4.00 ns	4.000		1.80	6.20
200 $\mu$ s Period/4.00 ns	4.000		1.80	6.20
2 ms Period/40.00 ns	40.000		36.00	44.00

**MeasZ Resistance Verification**

The verification procedure for the MeasZ Resistance function is a resistance measurement of a known value resistance and then compare the measured resistance to the value of the resistor.

This procedure uses:

- Resistors of known values: 1.5 M $\Omega$ , 1 M $\Omega$ , 60  $\Omega$ , 50  $\Omega$ , and 40  $\Omega$  nominal.

- Adapters to connect resistors to a BNC(f) connector.
- Output cable supplied with the SC1100

To do a measz resistance verification:

1. Set the Calibrator to SCOPE mode, with the MeasZ menu shown in the display.
2. Set the Calibrator MeasZ resistance range to the value shown in Table 7-25.

*Note*

*The MeasZ softkey toggles the MeasZ ranges.*

3. Connect one end of the output cable to the SCOPE connector of the Calibrator.
4. Connect the resistor shown in Table 7-25 to the other end of the output cable. See Figure 7-6.

*Note*

*The resistor must make a solid connection to a BNC(f) connector. The resistance value must be known at this BNC(f) connector. Fluke uses an HP 3458A DMM to make a 4-wire measurement at the BNC(f) connector to get the actual resistance.*

5. Let the Calibrator measurement become stable.
6. Record the measurement in Table 7-25.
7. Compare the measured resistance value to the actual resistance of the resistor and the value in the tolerance column of the table.

**Table 7-25. MeasZ Resistance Verification**

Calibrator MeasZ Range	Nominal Resistance Value	Calibrator Resistance Measurement	Actual Resistance Value	Tolerance
res 50Ω	40 Ω			0.04 Ω
res 50Ω	50 Ω			0.05 Ω
res 50Ω	60 Ω			0.06 Ω
res 1MΩ	600 kΩ <sup>[1]</sup>			600 Ω
res 1MΩ	1 MΩ			1 kΩ
res 1MΩ	1.5 MΩ			1.5 kΩ

[1] 600 kΩ is made with the 1.5 MΩ and 1 MΩ resistors connected in parallel.

### **MeasZ Capacitance Verification**

The verification procedure for the MeasZ Capacitance function is a capacitance measurement of a known value capacitance and then compare the measured capacitance to the value of the capacitance.

This procedure uses:

- Adapter and capacitors to make 5 pF, 29 pF, and 49 pF nominal values at the end of a BNC(f) connector.
- Output cable supplied with the SC1100

To do a MeasZ capacitance verification:

1. Set the Calibrator to SCOPE mode, with the MeasZ menu shown in the display.

- Set the Calibrator MeasZ capacitance range to **cap**.

*Note*

*The MeasZ softkey toggles the MeasZ ranges.*

- Connect one end of the output cable to the SCOPE connector of the Calibrator. Do not connect anything to the other end of this cable.
- Let the Calibrator measurement become stable and then push the **SET OFFSET** softkey to zero the capacitance measurement.
- Connect the other end of the cable to the capacitance shown in Table 7-26. See Figure 7-6.
- Let the Calibrator measurement become stable.
- Record the measurement in Table 7-26.
- Compare the measured capacitance value to the actual capacitance and the value in the tolerance column of the table.

**Table 7-26. MeasZ Capacitance Verification**

Nominal Capacitance Value	Calibrator Capacitance Measurement	Actual Capacitance Value	Tolerance
5 pF			0.75 pF
29 pF			1.95 pF
49 pF			2.95 pF

**Overload Function Verification**

This procedure uses:

- 50  $\Omega$  feedthrough termination
- Output cable supplied with the SC1100

To do an overload function verification:

- Connect the output cable and 50  $\Omega$  feedthrough termination to the Calibrator as shown in Figure 7-15.

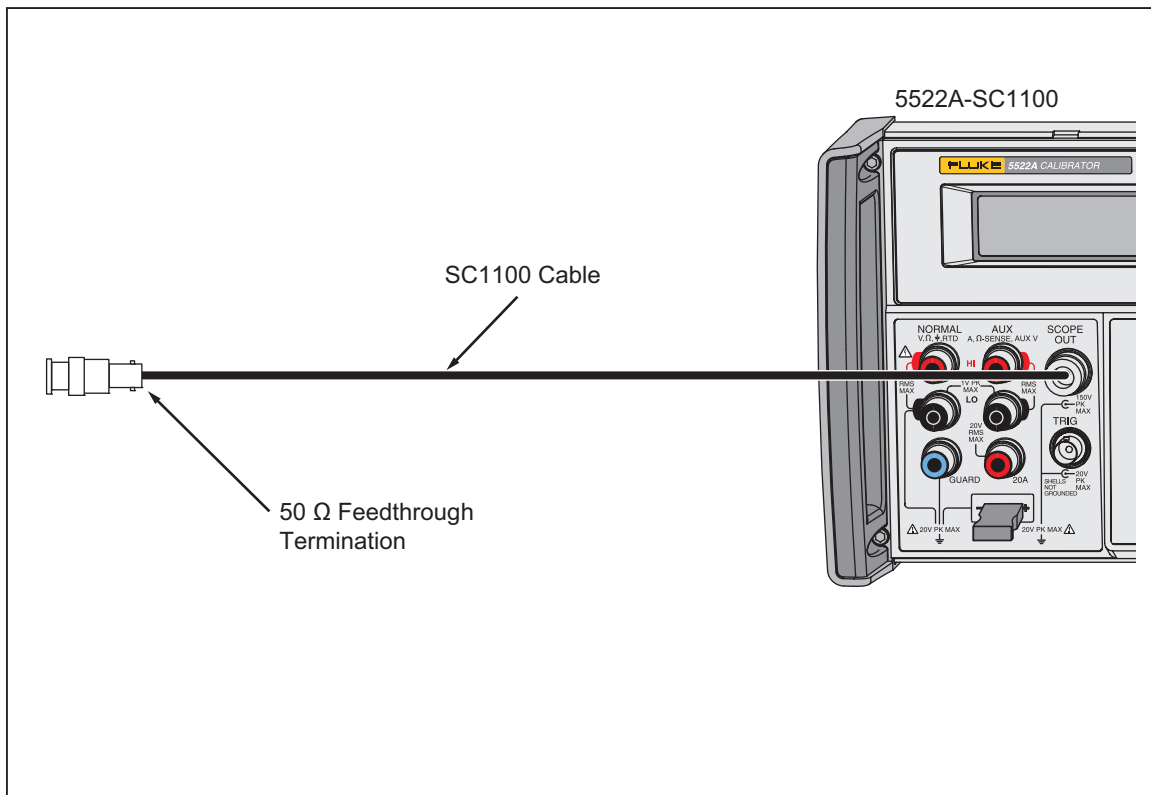

Figure 7-15. Overload Function Verification Connections

gjh141.eps

2. Set the Calibrator to SCOPE mode, with the Overload menu shown in the display.
3. Connect one end of the output cable to the 50 Ω feedthrough termination.
4. Connect the other end of the output cable to the SCOPE connector of the Calibrator.
5. Set the Calibrator to output 5.000 V, dc (**OUT VAL** softkey), and time limit = 60 s (**T LIMIT** softkey).
6. Push **OPR** on the Calibrator and make sure the OPR timer display increments.
7. Remove the 50 Ω feedthrough termination before 60 seconds and make sure the Calibrator goes to standby (**STBY**).
8. Replace the 50 Ω feedthrough termination on the end of the output cable.
9. Set the Calibrator output to 5.000 V, ac (**OUT VAL** softkey).
10. Push **OPR** on the Calibrator and make sure the OPR timer display increments.
11. Remove the 50 Ω feedthrough termination before 60 seconds and make sure the Calibrator goes to standby (**STBY**).

## SC1100 Hardware Adjustments

Hardware adjustments must be made to the leveled sine and edge functions each time the SC1100 is repaired. This section contains the adjustment procedures and a test equipment list with recommended models that are necessary to do these adjustments. Equivalent models can be used if necessary.

### Necessary Equipment

To do the hardware adjustments in this section, you must have:

- Standard adjustment tool to adjust the pots and trimmer caps

- Extender Card
- Oscilloscope Mainframe and Sampling Head (Tektronix 11801 with SD-22/26 or Tektronix TDS 820 with 8 GHz bandwidth)
- 10 dB Attenuator (Weinschel 9-10 (SMA), or Weinschel 18W-10, or equivalent)
- Output cable supplied with the SC1100
- Spectrum Analyzer (Hewlett-Packard 8590A)

*Note*

*The models shown in this list are recommended to get accurate results.*

### **How to Adjust the Leveled Sine Wave Function**

There are two adjustment procedures that you must do for the leveled sine wave function. The first procedure adjusts the balance out of the **LO VCO** so that the signal is balanced between the two VCOs. The second procedure adjusts the harmonics.

#### **Equipment Setup**

This procedure uses the spectrum analyzer. Before you start this procedure, make sure that the Calibrator is in leveled sine wave mode (the Levsine menu shows in the display), and set it to output 5.5 V p-p @ 600 MHz.

1. Push **OPR**.
2. Connect the equipment as shown in Figure 7-10.
3. Adjust the Spectrum Analyzer so that it shows one peak across its horizontal center line in the display. The far right of the peak is fixed at the far right of the center line, as shown in Figure 7-16.

### **How to Adjust the Leveled Sine Wave VCO Balance**

To adjust leveled sine wave VCO balance:

*Note*

*The equipment must be setup as described in the Equipment Setup section.*

1. Set the Calibrator to 5.5 V @ 600 MHz.
2. Set the Spectrum Analyzer to:
  - Start frequency: 10 MHz
  - Stop frequency: 800 MHz
  - Resolution bandwidth: 30 kHz
  - Video Bandwidth: 3 kHz
  - Reference level: 20 dBm

The spectrum analyzer will show a spur at 153 MHz. See Figure 7-16 to identify the spur.

3. Turn R1 counterclockwise until the spur is at minimum amplitude.

*Note*

*As you turn R1, the spur will move down the waveform in the display. Stop the adjustment with the spur is at minimum amplitude. If you adjust too far, the spur will disappear.*

The signal is balanced between the VCOs and the adjustment is complete when the spur is at minimum amplitude.

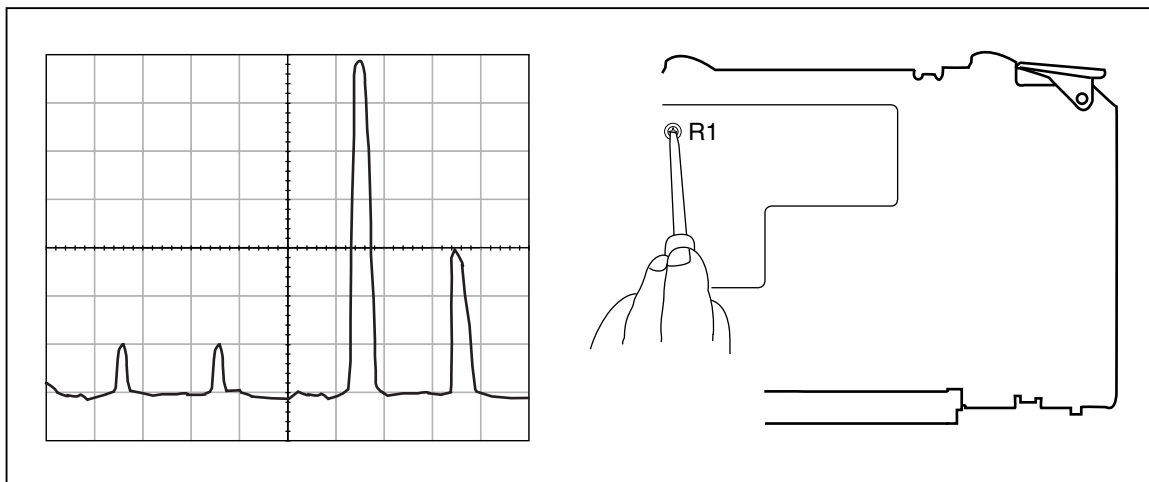

Figure 7-16. Levelled Sine Wave Balance Adjustment

om052f.eps

### How to Adjust the Levelled Sine Wave Harmonics

To adjust the leveled sine wave harmonics:

*Note*

*The equipment must be setup as described in the Equipment Setup section.*

1. Set the Calibrator to 5.5 V @ 600 MHz.
2. Set the Spectrum Analyzer to:
  - Start frequency 50 MHz
  - Stop frequency: 500 MHz
  - Resolution bandwidth: 3 MHz
  - Video Bandwidth: 3 kHz
  - Reference level: 20 dBm
3. Use the Peak Search function of the spectrum analyzer to find the reference signal. The spectrum analyzer will show the fundamental and second and third harmonics. The harmonics must be adjusted so that the second harmonic is at 40 dBc and the third harmonic is typically at 50 dBc as shown in Figure 7-17.
4. Adjust R8 until the peaks of the second and third harmonics are at the correct dB level.

*Note*

*As you adjust, it is possible the second harmonic will be at 40 dBc but the third harmonic is not at 50 dBc. Continue to adjust R8. The second harmonic will change, but there is a point at which the harmonics will be at the correct decibel level.*

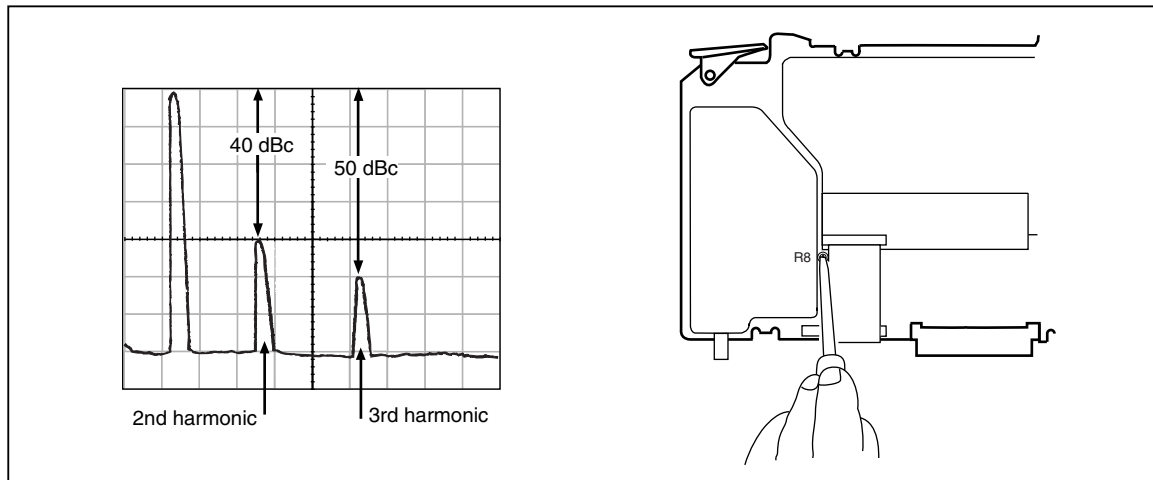

Figure 7-17. Levelled Sine Wave Harmonics Adjustment

om051f.eps

### How to Adjust the Aberrations for the Edge Function

You must do the adjustment procedure after you repair the edge function.

#### Note

*To make sure the edge aberrations are set to national standards, you must send the Calibrator to Fluke, or other company that has traceability for aberrations. Fluke has a reference pulse that is sent to the National Institute of Standards and Technology (NIST) for characterization. This data is then sent to high speed sampling heads, which are used to adjust and verify the SC1100.*

### Equipment Setup

This procedure uses:

- Oscilloscope: Tektronix 11801 with SD22/26 input module or Tektronix TDS 820 with 8 GHz bandwidth.
- 10 dB Attenuator: Weinschel 9-10 (SMA) or Weinschel 18W-10 or an equivalent
- Output cable supplied with the SC1100

Before you start the aberration adjustment procedure:

1. Connect the equipment as shown in Figure 7-8.
2. Set the Calibrator to SCOPE mode, with the Edge menu shown in the display.
3. Set the Calibrator to 1 V p-p @ 1 MHz.
4. Push **OPR**.
5. Set the DSO to:
  - Vertical scale: 10 mV/div
  - Horizontal scale: 1 ns/div
6. Set the DSO to show the 90 % point of the edge signal. Use this point as the reference level.
7. Set the DSO to show the first 10 ns of the edge signal with the rising edge at the left edge of the oscilloscope display.

### *How to Adjust the Edge Aberrations*

See Figure 7-18 while you do the adjustment procedure.

1. Adjust A90R13 to set the edge signal at the right edge of oscilloscope display, at 10 ns, to the reference level set above.
2. Adjust A90R36 so the first overshoot is the same amplitude as the subsequent highest aberration.
3. Adjust A90R35 so that the second and third overshoot aberrations are the same amplitude as the first aberration.
4. Adjust A90R12 to set the edge signal to occur between 2 ns and 10 ns to the reference level set above.
5. Adjust A90R36 and A90R35 again to get equal amplitudes for the first, second, and third aberrations.
6. Adjust A90R13 to set the edge signal to occur between 0 ns and 2 ns to the reference point set above. Put the aberrations in the center so the peaks are equal above and below the reference level.
7. Adjust A90R12 again if necessary to keep the edge signal to occur between 2 ns and 10 ns at the reference level.
8. Adjust A90R13 again if necessary to keep the edge signal to occur between 0 ns and 2 ns at the reference level.
9. Set the UUT output to 250 mV and the oscilloscope vertical to 2 mV/div. Examine the aberrations.
10. Connect the 10 dB attenuator to the oscilloscope input. Connect the UUT to the attenuator and set the UUT output to 2.5 V.
11. Set the oscilloscope vertical to 5 mV/div. Examine the aberrations.
12. Make sure the rise time is <300 ps at 250 mV, 1 V, and 2.5 V outputs.

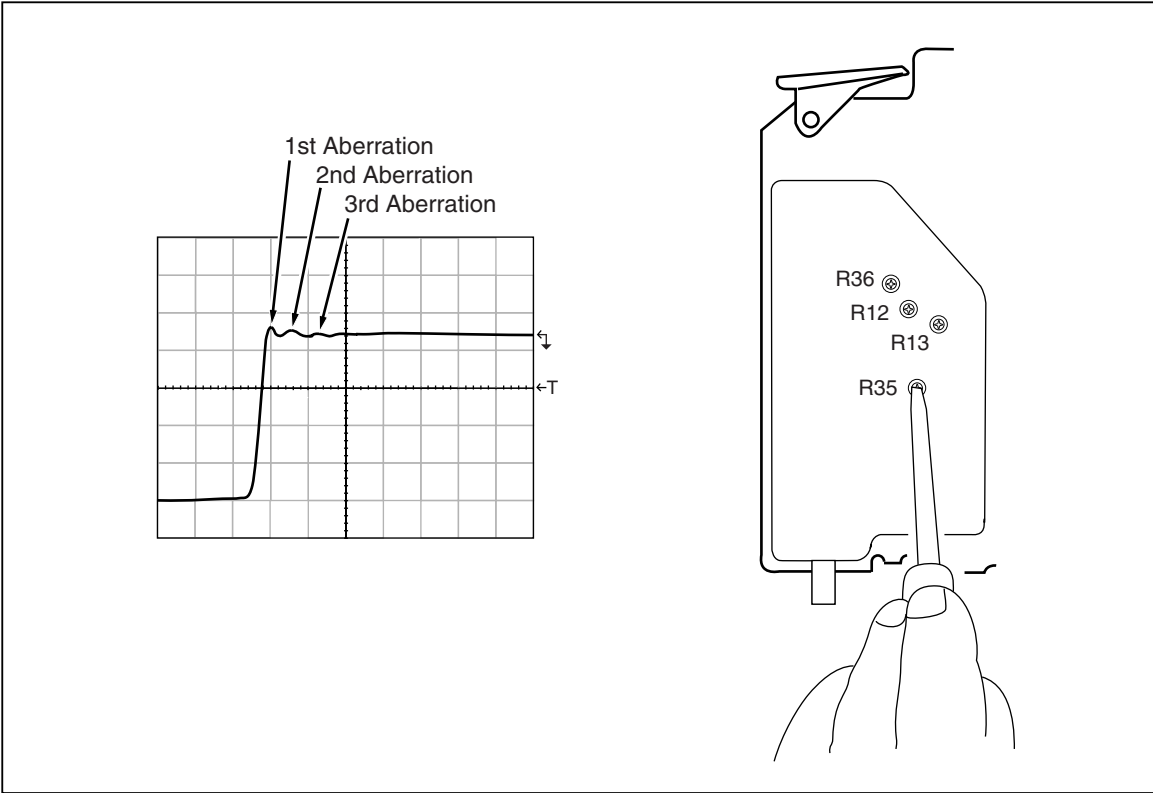

om050f.eps

Figure 7-18. Edge Aberrations Adjustment



# Chapter 8

## *PQ Calibration Option*

Title	Page
Introduction.....	8-3
PQ Options Specifications .....	8-3
Composite Harmonic Function Specifications .....	8-3
AC Voltage Specifications .....	8-4
AC Voltage Auxiliary Specifications (Dual Output Mode Only) .....	8-5
AC Current Specifications, LCOMP OFF .....	8-5
AC Current Specifications, LCOMP ON* .....	8-6
Flicker Simulation Mode .....	8-7
Sags & Swells Simulation Mode .....	8-7
Phase Specifications, Sinewave Outputs .....	8-7
Theory of Operation.....	8-7
DDS PCA (A6).....	8-8
Main CPU PCA (A9).....	8-8
Maintenance.....	8-8
Equipment Necessary for PQ Option Calibration and Verification.....	8-8
Performance Verification Tests .....	8-9
Delta Amplitude Verification .....	8-9
Composite Harmonics Verification .....	8-10
Calibration .....	8-20
Normal AC Voltage.....	8-21
AUX AC Current.....	8-21
AUX AC Voltage .....	8-22



## Introduction

This chapter contains information and procedures to do the servicing of the PQ Option.

## PQ Options Specifications

These specifications apply only to the PQ Option. General specifications for the Calibrator mainframe can be found in Chapter 1. The specifications are correct for these conditions:

- The Calibrator is operated in the conditions specified in Chapter 1.
- The Calibrator has completed a warm-up period that is two times the period the Calibrator was turned off to a maximum of 30 minutes.

### Composite Harmonic Function Specifications

<b>Maximum Number of Harmonics in a User Defined Waveform</b>	15
<b>Specified Fundamental Frequencies</b>	15-65 Hz, 400 Hz <sup>[1]</sup>
<b>Highest Harmonic Frequency</b>	5 kHz <sup>[2]</sup>
<b>Harmonic Amplitude Resolution</b>	0.1 % of fundamental
<b>Harmonic Phase Range (relative to fundamental)</b>	0 to 360 °
<b>Harmonic Phase Resolution</b>	0.1 ° relative to fundamental
<b>Pre-loaded Industry Waveforms</b>	IEC A, IEC D, NRC7030, NRC 2 to 5
<p>[1] AC Voltage outputs <math>\geq 33</math> V, and Current outputs <math>\geq 3</math> A have low frequency limits of 45 Hz. Other fundamental frequencies within the output limits of the 5522A can be used, but are not specified.</p> <p>[2] Current outputs with LCOMP ON have lower limits, as shown in the AC Current table below. Voltage outputs &gt; 33V have a 2 kHz limit.</p>	

Note

All harmonic specifications below include the fundamental. For waveforms with no harmonics other than the fundamental, the RMS uncertainty is the same as the non-PQ mode of the 5522A.

**AC Voltage Specifications**

Composite Waveform Ranges	Harmonic Frequency	Harmonic Amplitude Range (% of Fundamental) <sup>[1]</sup>	Harmonic Amplitude Uncertainty (% of Fundamental + V)	Harmonic Phase Uncertainty (Relative to Fundamental) <sup>[2]</sup>	Absolute RMS Uncertainty of Composite Waveform (% RMS + V)
1 to 32.999 mV	15 to 45 Hz	0.1 to 100 %	0.1 % + 10 $\mu$ V	0.5 °	0.20 % + 6 $\mu$ V
	45 to 900 Hz	0.1 to 100 %	0.1 % + 10 $\mu$ V	0.5 °	
	900 Hz to 2 kHz	0.1 to 100 %	0.1 % + 10 $\mu$ V	1 °	
	2 to 5 kHz	0.1 to 100 %	0.1 % + 30 $\mu$ V	3 °	
33 to 329.99 mV	15 to 45 Hz	0.1 to 100 %	0.1 % + 60 $\mu$ V	0.5 °	0.20 % + 10 $\mu$ V
	45 to 900 Hz	0.1 to 100 %	0.1 % + 60 $\mu$ V	0.5 °	
	900 Hz to 2 kHz	0.1 to 100 %	0.1 % + 60 $\mu$ V	0.8 °	
	2 to 5 kHz	0.1 to 100 %	0.1 % + 60 $\mu$ V	2 °	
0.33 to 3.2999 V	15 to 45 Hz	0.1 to 100 %	0.1 % + 400 $\mu$ V	0.5 °	0.20 % + 100 $\mu$ V
	45 to 900 Hz	0.1 to 100 %	0.1 % + 400 $\mu$ V	0.3 °	
	900 Hz to 2 kHz	0.1 to 100 %	0.1 % + 400 $\mu$ V	0.5 °	
	2 to 5 kHz	0.1 to 100 %	0.1 % + 400 $\mu$ V	2 °	
3.3 to 32.999 V	15 to 45 Hz	0.1 to 100 %	0.1 % + 4 mV	0.5 °	0.20 % + 1 mV
	45 to 900 Hz	0.1 to 100 %	0.1 % + 4 mV	0.3 °	
	900 Hz to 2 kHz	0.1 to 100 %	0.1 % + 4 mV	0.5 °	
	2 to 5 kHz	0.1 to 100 %	0.1 % + 4 mV	2 °	
33 to 329.99 V	45 to 440 Hz	0.1 to 100 %	0.2 % + 20 mV	0.75 °	0.20 % + 10 mV
	440 to 660 Hz	0.1 to 30 %	0.25 % + 20 mV	1.2 °	
	660 to 1.2 kHz	0.1 to 10 %	0.35 % + 25 mV <sup>[3]</sup>	3 °	
	1.2 to 2 kHz	0.1 to 5 %	0.5 % + 40 mV <sup>[4]</sup>	5 °	
330 to 1020 V	45 to 440 Hz	0.1 to 100 %	0.25 % + 100 mV	0.75 °	0.20 % + 100 mV
	440 to 660 Hz	0.1 to 30 %	0.25 % + 100 mV	1.2 °	
	660 to 1.2 kHz	0.1 to 10 %	0.4 % + 100 mV <sup>[5]</sup>	3 °	
	1.2 to 2 kHz	0.1 to 5 %	0.6 % + 160 mV <sup>[6]</sup>	5 °	
<p>[1] All frequencies can have harmonics that are up to 100 % of the fundamental, but uncertainties are not specified unless otherwise indicated.</p> <p>[2] For harmonics that are &lt; 1 % of the Fundamental, phase uncertainty is typical.</p> <p>[3] When harmonics of this frequency band are combined with harmonics 45 to 660 Hz, all 45 to 660 Hz harmonics have an uncertainty of 0.35 % + 25 mV.</p> <p>[4] When harmonics of this frequency band are combined with harmonics 45 Hz to 1.2 kHz, all 45 Hz to 1.2 kHz harmonics have an uncertainty of 0.4 % + 25 mV.</p> <p>[5] When harmonics of this frequency band are combined with harmonics 45 to 660 Hz, all 45 to 660 Hz harmonics have an uncertainty of 0.4 % + 100 mV.</p> <p>[6] When harmonics of this frequency band are combined with harmonics 45 Hz to 1.2 kHz, all 45 Hz to 1.2 kHz harmonics have an uncertainty of 0.5 % + 100 mV.</p>					

**AC Voltage Auxiliary Specifications (Dual Output Mode Only)**

Range, Composite Waveform	Harmonic Frequency	Harmonic Amplitude Range (% of Fundamental)	Harmonic Amplitude Uncertainty (% of Fundamental + V)	Harmonic Phase Uncertainty (Relative to Fundamental) <sup>[1]</sup>	Absolute RMS Uncertainty of Composite Waveform (% RMS + V)
10 to 329.99 mV	15 to 45 Hz	0.1 to 100 %	0.1 % + 100 μV	0.5 °	0.2 % + 100 μV
	45 Hz to 1 kHz	0.1 to 100 %	0.1 % + 100 μV	1 °	
	1 to 2 kHz	0.1 to 50 %	0.1 % + 100 μV	3 °	
	2 to 5 kHz	0.1 to 30 %	0.1 % + 500 μV	6 °	
.33 to 3.2999 V	15 to 45 Hz	0.1 to 100 %	0.1 % + 1 mV	0.5 °	0.2 % + 1 mV
	45 Hz to 1 kHz	0.1 to 100 %	0.1 % + 1 mV	0.75 °	
	1 to 2 kHz	0.1 to 50 %	0.1 % + 1 mV	2 °	
	2 to 5 kHz	0.1 to 30 %	0.1 % + 2 mV	3 °	
3.3 to 5 V	15 to 45 Hz	0.1 to 100 %	0.2 % + 3 mV	0.5 °	0.2 % + 2 mV
	45 Hz to 1 kHz	0.1 to 100 %	0.2 % + 3 mV	0.75 °	
	1 to 2 kHz	0.1 to 50 %	0.2 % + 3 mV	2 °	
	2 to 5 kHz	0.1 to 30 %	0.3 % + 3 mV	3 °	

[1] For harmonics that are < 1 % of the Fundamental, phase uncertainty is typical.

**AC Current Specifications, LCOMP OFF**

Range, Composite Waveform	Harmonic Frequency	Harmonic Amplitude Range (% of Fundamental) <sup>[1]</sup>	Harmonic Amplitude Uncertainty (% of Fundamental + A)	Harmonic Phase Uncertainty (Relative to Fundamental) <sup>[2]</sup>	Absolute RMS Uncertainty of Composite Waveform (% RMS + A)
29 to 329.9 μA	15 to 45 Hz	0.1 to 100 %	0.1 % + 0.1 μA	0.5 °	0.2 % + 0.1 μA
	45 to 900 Hz	0.1 to 100 %	0.1 % + 0.1 μA	2 °	
	900 Hz to 2 kHz	0.1 to 50 %	0.1 % + 0.1 μA	3 °	
	2 to 5 kHz	0.1 to 30 %	0.1 % + 0.13 μA	6 °	
0.33 to 3.299 mA	15 to 45 Hz	0.1 to 100 %	0.1 % + 1 μA	0.5 °	0.2 % + 1 μA
	45 to 900 Hz	0.1 to 100 %	0.1 % + 1 μA	0.6 °	
	900 Hz to 2 kHz	0.1 to 50 %	0.1 % + 1 μA	0.75 °	
	2 to 5 kHz	0.1 to 30 %	0.1 % + 1.3 μA	2 °	
3.3 to 32.99 mA	15 to 45 Hz	0.1 to 100 %	0.1 % + 10 μA	0.5 °	0.2 % + 10 μA
	45 to 900 Hz	0.1 to 50 %	0.1 % + 10 μA	0.6 °	
	900 Hz to 2 kHz	0.1 to 30 %	0.1 % + 10 μA	0.75 °	
	2 to 5 kHz	0.1 to 100 %	0.1 % + 13 μA	2 °	
33 to 329.9 mA	15 to 45 Hz	0.1 to 100 %	0.1 % + 100 μA	0.5 °	0.2 % + 100 μA
	45 to 900 Hz	0.1 to 100 %	0.1 % + 100 μA	0.75 °	
	900 Hz to 2 kHz	0.1 to 50 %	0.1 % + 100 μA	1.5 °	
	2 to 5 kHz	0.1 to 30 %	0.1 % + 130 μA	3 °	

[1] All frequencies can have harmonics up to 100 % of the fundamental; uncertainties are not specified unless otherwise indicated.  
[2] For harmonics that are < 1 % of the Fundamental, phase uncertainty is typical.

**AC Current Specifications, LCOMP OFF (continued)**

Range, Composite Waveform	Harmonic Frequency	Harmonic Amplitude Range (% of Fundamental) <sup>[1]</sup>	Harmonic Amplitude Uncertainty (% of Fundamental + A)	Harmonic Phase Uncertainty (Relative to Fundamental) <sup>[2]</sup>	Absolute RMS Uncertainty of Composite Waveform (% RMS + A)
0.33 to 2.999 A	15 to 45 Hz	0.1 to 100 %	0.1 % + 1 mA	0.5 °	0.2 % + 1 mA
	45 to 900 Hz	0.1 to 100 %	0.1 % + 1 mA	0.6 °	
	900 Hz to 2 kHz	0.1 to 20 %	0.1 % + 1 mA	1 °	
	2 to 5 kHz	0.1 to 20 %	0.2 % + 1.3 mA	2 °	
3 to 20.5 A	15 to 45 Hz	0.1 to 100 %	0.1 % + 10 mA	0.5 °	0.2 % + 10 mA
	45 to 900 Hz	0.1 to 100 %	0.1 % + 10 mA	0.6 °	
	900 Hz to 2 kHz	0.1 to 20 %	0.1 % + 10 mA	1 °	
	2 to 5 kHz	0.1 to 20 %	0.2 % + 10 mA	3 °	
<p>[1] All frequencies can have harmonics up to 100 % of the fundamental; uncertainties are not specified unless otherwise indicated.                  [2] For harmonics that are &lt;1 % of the Fundamental, phase uncertainty is typical.</p>					

**AC Current Specifications, LCOMP ON\***

Range, Composite Waveform	Harmonic Frequency	Harmonic Amplitude Range (% of Fundamental) <sup>[1]</sup>	Harmonic Amplitude Uncertainty (% of Fundamental + A)	Harmonic Phase Uncertainty (Relative to Fundamental) <sup>[2]</sup>	Absolute RMS Uncertainty of Composite Waveform (% RMS + A)
29 to 329.99 µA	15 to 65 Hz	0.1 to 30 %	0.5 % + 0.1 µA	0.5 °	0.5 % + 1 µA
	65 to 900 Hz	0.1 to 30 %	1.0 % + 0.1 µA	2 °	
0.33 to 3.2999 mA	15 to 65 Hz	0.1 to 30 %	0.5 % + 1 µA	0.5 °	0.5 % + 1 µA
	65 to 900 Hz	0.1 to 30 %	1.0 % + 1 µA	1 °	
3.3 to 32.999 mA	15 to 65 Hz	0.1 to 30 %	0.4 % + 10 µA	0.5 °	0.5 % + 10 µA
	65 to 900 Hz	0.1 to 30 %	0.6 % + 10 µA	1 °	
33 to 329.9 mA	15 to 65 Hz	0.1 to 30 %	0.4 % + 100 µA	0.5 °	0.5 % + 100 µA
	65 to 900 Hz	0.1 to 30 %	0.6 % + 100 µA	1 °	
0.33 to 2.999 A	15 to 65 Hz	0.1 to 30 %	0.5 % + 1 mA	0.75 °	0.5 % + 1 mA
	65 to 440 Hz	0.1 to 30 %	1.0 % + 1 mA	1 °	
3 to 20.5 A	15 to 65 Hz	0.1 to 30 %	0.5 % + 10 mA	0.75 °	0.75 % + 10 mA
	65 to 440 Hz	0.1 to 30 %	1.0 % + 10 mA	1 °	
<p>* LCOMP ON is used to drive inductive loads like the 5500A/COIL and current clamps.                  [1] All frequencies can have harmonics up to 100 % of the fundamental; uncertainties are not specified unless otherwise indicated.                  [2] For harmonics that are &lt;1 % of the Fundamental, phase uncertainty is typical.</p>					

### Flicker Simulation Mode

<b>Voltage Range</b>	1 mV to 1020 V	
<b>Current Range</b>	29 $\mu$ A to 20.5 A	
<b>Frequency of Fundamental</b>	50 and 60 Hz	
<b>Amplitude Modulation Range</b>	$\pm 100$ %	
<b>Frequency of Modulation</b>	0.1 to 40 Hz	
<b>Type of Modulation</b>	Square or Sine	
<b>Short Term (10 minute) uncertainty of amplitude modulation</b>	$\pm 0.1$ % of nominal output + 0.05% of range	
<b>Flicker Modulation Timing Uncertainty</b>	$\pm 0.1$ ms	
<b>Settings for Pst = 1</b>	Voltage Changes $\Delta V/V$ % <sup>[1]</sup>	
<b>Changes per minute:</b>	120V, 60 Hz	230V, 50 Hz
1 chg/min	3.166 %	2.724 %
2 chg/min	2.568 %	2.211 %
7 chg/min	1.695 %	1.459 %
39 chg/min	1.044 %	0.906 %
110 chg/min	0.841 %	0.725 %
1620 chg/min	0.547 %	0.402 %
4000 chg/min	N/A	2.40 %
4800 chg/min	3.920 %	N/A
<b>Trigger Event</b>	2 <sup>nd</sup> Push of OPER key, or Remote Command	
[1] Values shown are nominal values per IEC 61000-4-15. The 5522A-PQ has a limited resolution of 0.02 % in the Flicker Simulation Mode.		

### Sags & Swells Simulation Mode

<b>Voltage Range</b>	1 mV to 1020 V
<b>Current Range</b>	29 $\mu$ A to 20.5 A
<b>Frequency of Fundamental</b>	45 to 65 Hz
<b>Amplitude Modulation Range</b>	$\pm 100$ %
<b>Ramp-Up Time</b>	0.01 to 1 second
<b>Duration of Sag or Swell</b>	0.032 to 60 seconds
<b>Trigger Event</b>	2 <sup>nd</sup> Push of OPER key, or Remote Command

### Phase Specifications, Sinewave Outputs

The 5522A-PQ option has improved phase uncertainty in the normal, non-PQ, dual outputs as shown below. (See the 5522A specifications for all other output combinations.)

Output Combinations, 45 Hz to 65 Hz			1-Year Absolute Uncertainty
AC Voltage	AC Voltage (Auxiliary)	AC Current (LCOMP OFF)	0.07 °
0.65 to 3.29999 V	0.65 to 3.29999 V	6.5 to 32.999 mA	
6.5 to 32.9999 V		65 to 329.99 mA	
65 to 329.9999 V		0.65 to 10.9999 A	

### Theory of Operation

The PQ option is different from a standard 5522A as it uses an updated DDS PCA (A6), Main CPU PCA (A9), and outguard firmware version 3.0 or later. This section contains a brief overview of the changes made to the DDS PCA and the Main CPU.

### DDS PCA (A6)

The PQ option uses the 5520A-PQ-7606 A6 PCA, P/N 1577331, as the DDS PCA. It uses 12-bit DACs (Digital to Analog converter) for the voltage and current channels. A dual-channel DDS (Direct Digital Synthesis) integrated circuit is used to supply the Composite Harmonics and Delta Amplitude functions. Feedback through a precision ac converter gives the output accuracy of the Composite Harmonics. In the Composite Harmonics mode, the phase monitors usually used for sinusoidal outputs at the same time are turned off.

The Delta Amplitude mode amplitude accuracy is contingent on the performance of the voltage and current digital to analog converters (DACs). As a result, a special calibration adjustment is necessary for the PQ option, as contained in the Maintenance section.

This DDS PCA can also be used in a standard 5520A with outguard firmware version 3.0 or later.

### Main CPU PCA (A9)

The Main CPU PCA must have more RAM installed (U32 and U33) for the PQ option to operate.

## Maintenance

There are no maintenance procedures or diagnostic remote commands for the PQ option that are available to users. If the PQ Option is installed, the two PQ sofkeys will show when you push **MORE MODES**. If the option is not installed, only the pressure softkey will be shown.

## Equipment Necessary for PQ Option Calibration and Verification

Table 8-1 is a list of equipment necessary for calibration and verification of the PQ Option.

**Table 8-1. SC1100 Calibration and Verification Equipment**

Instrument	Model	Minimum Use Specifications
Digital Multimeter	HP 3458A	RMS measurements of 300 $\mu$ A to 300 mA, 60 Hz. 0.1 % uncertainty or better.
2 A and 20 A Shunt	Fluke Y5020 (or Measure Tech EL 7520) or Fluke A40 2A and 20A	RMS measurements of 2 A and 10 A, 60 Hz. 0.1 % uncertainty or better.
Harmonic Analyzer	LEM Norma D6000 with option 61E1 Harmonic Analyzer and plug-ins 6111, 61U1, & 61U2, & 30mA-10A triaxial shunt.	RMS measurement of 600 V, 10 A. Capability to measure harmonic amplitude and phase up to the 63 <sup>rd</sup> . [1]
AC Measurement Standard	Fluke 5790A	RMS measurement from 30 mV to 1000 V, 60 Hz. 0.05 % uncertainty or better.
[1] Option 61E1 is used to make optional PST measurements.		

## Performance Verification Tests

The verification tests in this section are used to verify the performance of the PQ option. Always do a verification test after major instrument repair. A verification test after routine calibration is not always necessary.

If an out-of-tolerance condition is found in the Composite Harmonics section, the instrument mainframe can be re-calibrated with the procedure in the 5520A Service Manual. If an out-of-tolerance condition is found in the Delta Amplitude section, the PQ option can be re-calibrated with the procedures in this section of the manual.

The test equipment necessary to do these verification tests is a complex waveform analyzer. The LEM Norma D6000 with option 61E1 Harmonic Analyzer and plug-ins 61I1, 61U1, & 61U2, is such an analyzer. You must first characterize the Norma D6000 to get the necessary test uncertainty ratios (TURs) for all tests. These tests are functional, unless your calibration lab can do the necessary measurement uncertainties. An alternative, is to send the Calibrator to a Fluke Service Center.

### Delta Amplitude Verification

The delta amplitude verification is done in two steps: static condition and flicker condition. To do the verification for the static condition:

1. Connect Fluke 5790A or HP 3458A to the Normal output terminals of the PQ option.
2. Set the Calibrator in the Delta Amplitude mode to the values shown in Table 8-2. Make sure the Delta Amplitude is set to 0 %.
3. Compare the measurement to the value in the specification column of Table 8-2.

**Table 8-2. Delta Amplitude Verification, Static Condition**

Calibrator Output		Specification
Amplitude	Frequency	
30 V	60 Hz	0.06
300 V	50 Hz	0.6

To do the verification for the flicker condition:

1. Connect the Harmonic Analyzer or DMM to the normal output of the PQ option.
2. Set the Calibrator to the values shown in Table 8-3.
3. Measure the delta V with the ACV mode of the Analyzer.
4. Set the time average to 0.3 seconds on the Analyzer.

*Note*

*If you use the HP 3458A as the measurement instrument, set NPLC to 1. Make sure the rangelock the HP 3458A to the 1000 V range.*

5. Record the high and low measurements and calculate the delta V.
6. Compare the calculated delta V with the value in the Specification column of Table 8-3.

**Table 8-3. Delta Amplitude Verification, Flicker Condition**

Calibrator Output					Specification (V)
Amplitude	Frequency	Pst Setting	Nominal Delta V	Repeat Frequency	
230 V	50 Hz	1	1.459 %	58.30 mHz	0.172 %
230 V	50 Hz	1	0.906 %	325.00 mHz	0.172 %
230 V	50 Hz	3	2.718 %	325.00 mHz	0.172 %
230 V	50 Hz	5	7.295 %	58.30 mHz	0.172 %

**Composite Harmonics Verification**

Tables 8-4 refers to waveform descriptions in this manual and those waveforms that are made in the composite harmonics mode.

*Note*

*All tests must be done with the 5522A EARTH key turned on.*

**Table 8-4. Composite Harmonics Verification**

Verification Tests for AC Voltage		Harmonic	Fundamental	Phase	Amplitude (V)	Specification (V)	Specification (deg)
<b>Range</b>	329.99 mV	rms			0.12000	2.500E-04	
<b>Wave</b>	I	1	100.0 %		0.03000	9.00E-5	
<b>RMS Output</b>	0.12 V	3	100.0 %	0	0.03000	9.00E-5	0.5
<b>Frequency</b>	50.0 Hz	6	100.0 %	0	0.03000	9.00E-5	0.5
		9	100.0 %	0	0.03000	9.00E-5	0.5
		12	100.0 %	0	0.03000	9.00E-5	0.5
		15	100.0 %	0	0.03000	9.00E-5	0.5
		16	100.0 %	0	0.03000	9.00E-5	0.5
		23	100.0 %	0	0.03000	9.00E-5	0.5
		28	100.0 %	0	0.03000	9.00E-5	0.8
		33	100.0 %	0	0.03000	9.00E-5	0.8
		38	100.0 %	0	0.03000	9.00E-5	0.8
		43	100.0 %	0	0.03000	9.00E-5	0.8
		48	100.0 %	0	0.03000	9.00E-5	2.0
		53	100.0 %	0	0.03000	9.00E-5	2.0
		58	100.0 %	0	0.03000	9.00E-5	2.0
		63	100.0 %	0	0.03000	9.00E-5	2.0

**Table 8-4. Composite Harmonics Verification (cont.)**

Verification Tests for AC Voltage		Harmonic	Fundamental	Phase	Amplitude (V)	Specification (V)	Specification (deg)
<b>Range</b>	3.2999 mV	rms			0.45000	0.001000	
<b>Wave</b>	I	1	100.0 %		0.11250	0.000513	
<b>RMS Output</b>	0.45 V	3	100.0 %	0	0.11250	0.5	
<b>Frequency</b>	60.0 Hz	6	100.0 %	0	0.11250	0.5	
		9	100.0 %	0	0.11250	0.000513	0.5
		12	100.0 %	0	0.11250	0.000513	0.5
		15	100.0 %	0	0.11250	0.000513	0.5
		16	100.0 %	0	0.11250	0.000513	0.5
		23	100.0 %	0	0.11250	0.000513	0.5
		28	100.0 %	0	0.11250	0.000513	0.8
		33	100.0 %	0	0.11250	0.000513	0.8
		38	100.0 %	0	0.11250	0.000513	0.8
		43	100.0 %	0	0.11250	0.000513	0.8
		48	100.0 %	0	0.11250	0.000513	2.0
		53	100.0 %	0	0.11250	0.000513	2.0
		58	100.0 %	0	0.11250	0.000513	2.0
		63	100.0 %	0	0.11250	0.000513	2.0
<b>Range</b>	32.999 V	rms			12.0000	0.0250	
<b>Wave</b>	I	1	100.0 %		3.0000	0.0070	
<b>RMS Output</b>	12 V	3	100.0 %	0	3.0000	0.0070	0.3
<b>Frequency</b>	60.0 Hz	6	100.0 %	0	3.0000	0.0070	0.3
		9	100.0 %	0	3.0000	0.0070	0.3
		12	100.0 %	0	3.0000	0.0070	0.3
		15	100.0 %	0	3.0000	0.0070	0.3
		16	100.0 %	0	3.0000	0.0070	0.5
		23	100.0 %	0	3.0000	0.0070	0.5
		28	100.0 %	0	3.0000	0.0070	0.5
		33	100.0 %	0	3.0000	0.0070	0.5
		38	100.0 %	0	3.0000	0.0070	2.0
		43	100.0 %	0	3.0000	0.0070	2.0
		48	100.0 %	0	3.0000	0.0070	2.0
		53	100.0 %	0	3.0000	0.0070	2.0
		58	100.0 %	0	3.0000	0.0070	2.0
		63	100.0 %	0	3.0000	0.0070	2.0

Table 8-4. Composite Harmonics Verification (cont.)

Verification Tests for AC Voltage		Harmonic	Fundamental	Phase	Amplitude (V)	Specification (V)	Specification (deg)
<b>Range</b>	329.99 V	rms			210.0000	0.4300	
<b>Wave</b>	II	1	100.0 %		91.6730	0.3917	
<b>RMS Output</b>	210 V	2	100.0 %	0	91.6730	0.3917	0.75
<b>Frequency</b>	60.0 Hz	3	100.0 %	0	91.6730	0.3917	0.75
		5	100.0 %	0	91.6730	0.3917	0.75
		7	100.0 %	0	91.6730	0.3917	0.75
		8	30.0 %	0	27.5020	0.3917	1.2
		12	30.0 %	0	27.5020	0.3917	3.0
		13	10.0 %	0	9.1670	0.3917	3.0
		16	10.0 %	0	9.1670	0.3917	3.0
		18	10.0 %	0	9.1670	0.4984	3.0
		21	10.0 %	0	9.1670	0.4984	5.0
		23	10.0 %	0	9.1670	0.4984	5.0
		25	10.0 %	0	9.1670	0.4984	5.0
		26	5.00 %	0	4.5840	0.4984	5.0
		30	5.00 %	0	4.5840	0.4984	5.0
33	5.00 %	0	4.5840	0.4984	5.0		
<b>Range</b>	1020 V	1	100.0 %		600.0000	1.300	
<b>Wave</b>	III	2	100.0 %	0	241.796	1.310	0.75
<b>RMS Output</b>	600 V	3	100.0 %	0	241.796	1.310	0.75
<b>Frequency</b>	50 Hz	5	100.0 %	0	241.796	1.310	0.75
		7	100.0 %	0	241.796	1.310	0.75
		8	100.0 %	0	241.796	1.310	1.2
		12	30.0 %	0	72.539	1.310	1.2
		13	10.0 %	0	24.180	1.310	1.2
		16	10.0 %	0	24.180	1.310	3.0
		18	10.0 %	0	24.180	1.310	3.0
		21	10.0 %	0	24.180	1.310	3.0
		23	10.0 %	0	24.180	1.310	3.0
		25	10.0 %	0	24.180	1.610	5.0
		26	5.00 %	0	12.090	1.610	5.0
		30	5.00 %	0	14.1880	1.610	5.0
		33	5.00 %	0	14.1880	1.610	5.0

**Table 8-4. Composite Harmonics Verification (cont.)**

Verification Tests for AC Voltage		Harmonic	Fundamental	Phase	Amplitude (V)	Specification (V)	Specification (deg)
<b>Range</b>	329.99 V Normal Voltage Output	rms			140.0000	290.00 mV	0.75
<b>Wave</b>	IV	1	100.0 %		50.985	122.58 mV	0.75
<b>RMS Output</b>	140 V	2	100.0 %	0	50.985	122.58 mV	0.75
<b>Frequency</b>	50 Hz	3	100.0 %	0	50.985	122.58 mV	0.75
		4	100.0 %	0	50.985	122.58 mV	0.75
		5	100.0 %	0	50.985	122.58 mV	0.75
		6	100.0 %	0	50.985	122.58 mV	0.75
		7	100.0 %	0	50.985	122.58 mV	0.75
		8	30.00 %	0	15.296	122.58 mV	0.75
		9	30.00 %	0	15.296	153.23 mV	1.2
		10	30.00 %	0	15.296	153.23 mV	1.2
		11	30.00 %	0	15.296	153.23 mV	1.2
		12	30.00 %	0	15.296	153.23 mV	1.2
		13	30.00 %	0	15.296	153.23 mV	1.2
<b>Range</b>	1020 V	rms			450.0000	1.0000	
<b>Wave</b>	IV	1	100.0 %		163.880	0.5122	0.75
<b>RMS Output</b>	450 V	2	100.0 %	0	163.880	0.5122	0.75
<b>Frequency</b>	50 Hz	3	100.0 %	0	163.880	0.5122	0.75
		4	100.0 %	0	163.880	0.5122	0.75
		5	100.0 %	0	163.880	0.5122	0.75
		6	100.0 %	0	163.880	0.5122	0.75
		7	100.0 %	0	163.880	0.5122	0.75
		8	30.00 %	0	49.164	0.5122	0.75
		9	30.00 %	0	49.164	0.5122	1.2
		10	30.00 %	0	49.164	0.5122	1.2
		11	30.00 %	0	49.164	0.5122	1.2
		12	30.00 %	0	49.164	0.5122	1.2
		13	30.00 %	0	49.164	0.5122	1.2

Table 8-4. Composite Harmonics Verification (cont.)

Verification Tests for AC Voltage		Harmonic	Fundamental	Phase	Amplitude (V)	Specification (V)	Specification (deg)
<b>Range</b>	32.999 V	rms			12.00000	0.02500	
<b>Wave</b>	SQUARE	1	100.00 %		10.87300	0.01487	
<b>RMS Output</b>	12 V	3	33.30 %	0	3.62100	0.01487	0.3
<b>Frequency</b>	60 Hz	5	20.00 %	0	2.17500	0.01487	0.3
		7	14.30 %	0	1.55500	0.01487	0.3
		9	11.10 %	0	1.20700	0.01487	0.3
		11	9.10 %	0	0.98948	0.01487	0.3
		13	7.70 %	0	0.83725	0.01487	0.3
		15	6.70 %	0	0.72852	0.01487	0.3
		17	5.90 %	0	0.64153	0.01487	0.5
		19	5.30 %	0	0.57629	0.01487	0.5
		21	4.80 %	0	0.52193	0.01487	0.5
		23	4.30 %	0	0.46756	0.01487	0.5
		25	4.00 %	0	0.43494	0.01487	0.5
		27	3.70 %	0	0.40232	0.01487	0.5
		29	3.40 %	0	0.36970	0.01487	0.5
31	3.20 %	0	0.34795	0.01487	0.5		
<b>Range</b>	329.99 V	rms			230.0000	0.8512	
<b>Wave</b>	NRC 7030	1	100.00 %		20.6550	0.8512	0.75
<b>RMS Output</b>	230 V	2	10.00 %	-115.5	20.6550	0.8512	0.75
<b>Frequency</b>	60 Hz	3	10.00 %	1.1	20.6550	0.8512	0.75
		4	10.00 %	-179.6	20.6550	0.8512	0.75
		5	10.00 %	13.3	20.6550	0.8512	0.75
		6	10.00 %	9.3	20.6550	0.8512	0.75
		7	10.00 %	73.5	20.6550	0.8512	0.75
		8	10.00 %	152.1	20.6550	0.8512	0.75
		9	10.00 %	-19.9	20.6550	0.8512	1.2
		10	10.00 %	-167.8	20.6550	0.8512	1.2
		11	10.00 %	85.9	20.6550	0.8512	1.2
		12	10.00 %	-37.3	20.6550	0.8512	1.2
		13	10.00 %	16.1	20.6550	0.8512	3.0
		14	10.00 %	-28.1	20.6550	0.8512	3.0

**Table 8-4. Composite Harmonics Verification (cont.)**

Verification Tests for AC Voltage		Harmonic	Fundamental	Phase	Amplitude (V)	Specification (V)	Specification (deg)
		15	10.00 %	94	20.6550	0.8512	3.0
		16	10.00 %	-173.4	20.6550	0.8512	3.0
		17	10.00 %	129.5	20.6550	0.8512	3.0
		18	10.00 %	-113.9	20.6550	0.8512	3.0
		19	10.00 %	37.6	20.6550	0.8512	3.0
		20	10.00 %	-52.3	20.6550	0.8512	3.0
		21	10.00 %	1.5	20.6550	0.8512	3.0
		22	10.00 %	14.3	20.6550	0.8512	3.0
		23	10.00 %	150.2	20.6550	0.8512	3.0
		24	10.00 %	7.1	20.6550	0.8512	3.0
		25	10.00 %	161.3	20.6550	1.0700	5.0
<b>Verification Tests for AC Voltage (AUX)</b>							
<b>Range</b>	5 V	rms			1.90000	.0..580	
<b>Wave</b>	V	1	100.00 %		0.58524	0.00417	
<b>RMS Output</b>	1.9 V	3	100.00 %	0	0.58524	0.00417	0.75
<b>Frequency</b>	60 Hz	6	100.00 %	0	0.58524	0.00417	0.75
		9	100.00 %	0	0.58524	0.00417	0.75
		12	100.00 %	0	0.58524	0.00417	0.75
		16	100.00 %	0	0.58524	0.00417	0.75
		17	100.00 %	0	0.58524	0.00417	2.0
		23	100.00 %	0	0.58524	0.00417	2.0
		28	100.00 %	0	0.58524	0.00417	2.0
		33	100.00 %	0	0.58524	0.00417	2.0
		38	30.00 %	0	0.17577	0.00476	3.0
		43	30.00 %	0	0.17577	0.00476	3.0
		48	30.00 %	0	0.17577	0.00476	3.0
		53	30.00 %	0	0.17577	0.00476	3.0
		58	30.00 %	0	0.17577	0.00476	3.0
		63	30.00 %	0	0.17577	0.00476	3.0

Table 8-4. Composite Harmonics Verification (cont.)

Verification Tests for AC Voltage		Harmonic	Fundamental	Phase	Amplitude (V)	Specification (V)	Specification (deg)
<b>Verification Tests for AC Current, LCOMP OFF</b>							
<b>Range</b>	329.99 mA	rms			0.11000	1.22E-03	
<b>Wave</b>	VI	1	100.00 %		0.03821	1.38E-04	
<b>RMS Output</b>	0.11 A	3	100.00 %	0	0.03821	1.38E-04	0.75
<b>Frequency</b>	50 Hz	6	100.00 %	0	0.03821	1.38E-04	0.75
		9	100.00 %	0	0.03821	1.38E-04	0.75
		12	100.00 %	0	0.03821	1.38E-04	0.75
		15	100.00 %	0	0.03821	1.38E-04	0.75
		18	100.00 %	0	0.03821	1.38E-04	1.5
		23	50.00 %	0	0.01910	1.38E-04	1.5
		28	50.00 %	0	0.01910	1.38E-04	1.5
		33	50.00 %	0	0.01910	1.38E-04	1.5
		38	30.00 %	0	0.01146	1.38E-04	1.5
		43	30.00 %	0	0.01146	1.68E-04	3.0
		48	30.00 %	0	0.01146	1.68E-04	3.0
		53	30.00 %	0	0.01146	1.68E-04	3.0
		58	30.00 %	0	0.01146	1.68E-04	3.0
63	30.00 %	0	0.01146	1.68E-04	3.0		
<b>Range</b>	2.999 A	rms			1.10000	0.00320	
<b>Wave</b>	VI	1	100.00 %		0.40547	0.00141	0.6
<b>RMS Output</b>	1.1 A	3	100.00 %	0	0.40547	0.00141	0.6
<b>Frequency</b>	50 Hz	6	100.00 %	0	0.40547	0.00141	0.6
		9	100.00 %	0	0.40547	0.00141	0.6
		12	100.00 %	0	0.40547	0.00141	0.6
		15	100.00 %	0	0.40547	0.00141	0.6
		18	20.00 %	0	0.40547	0.00141	0.6
		23	20.00 %	0	0.08109	0.00141	1.0
		28	20.00 %	0	0.08109	0.00141	1.0
		33	20.00 %	0	0.08109	0.00141	1.0
		38	20.00 %	0	0.08109	0.00141	1.0
		43	20.00 %	0	0.08109	0.00211	2.0
		48	20.00 %	0	0.08109	0.00211	2.0
		53	20.00 %	0	0.08109	0.00211	2.0
		58	20.00 %	0	0.08109	0.00211	2.0
63	20.00 %	0	0.08109	0.00211	2.0		

Table 8-4. Composite Harmonics Verification (cont.)

Verification Tests for AC Voltage		Harmonic	Fundamental	Phase	Amplitude (V)	Specification (V)	Specification (deg)
<b>Range</b>	20.5 A	rms			4.50000	0.0190	
<b>Wave</b>	VII	1	100.00 %		1.6590	0.0117	
<b>RMS Output</b>	4.5 A	3	100.00 %	0	1.6590	0.0117	0.6
<b>Frequency</b>	50 Hz	6	100.00 %	0	1.6590	0.0117	0.6
		9	100.00 %	0	1.6590	0.0117	0.6
		12	100.00 %	0	1.6590	0.0117	0.6
		15	100.00 %	0	1.6590	0.0117	0.6
		18	100.00 %	0	1.6590	0.0117	0.6
		23	20.00 %	0	0.3317	0.0117	1.0
		28	20.00 %	0	0.3317	0.0117	1.0
		33	20.00 %	0	0.3317	0.0117	1.0
		38	20.00 %	0	0.3317	0.0117	1.0
		43	20.00 %	0	0.3317	0.0133	3.0
		48	20.00 %	0	0.3317	0.0133	3.0
		53	20.00 %	0	0.3317	0.0133	3.0
		58	20.00 %	0	0.3317	0.0133	3.0
		63	20.00 %	0	0.3317	0.0133	3.0
<b>Range</b>	20.5 A	rms			4.80000	0.0196	
<b>Wave</b>	IECA	1	100.00 %		2.89500	0.0129	
<b>RMS Output</b>	4.8 A	2	47.00 %	0	1.35900	0.0129	0.6
<b>Frequency</b>	50 Hz	3	100.00 %	180	2.89500	0.0129	0.6
		4	18.70 %	180	0.54123	0.0129	0.6
		5	49.60 %	0	1.43500	0.0129	0.6
		6	13.00 %	0	0.37760	0.0129	0.6
		7	33.50 %	180	0.96918	0.0129	0.6
		8	10.00 %	180	0.28950	0.0129	0.6
		9	17.40 %	0	0.50347	0.0129	0.6
		10	8.00 %	0	0.23160	0.0129	0.6
		11	14.30 %	180	0.41536	0.0129	0.6
		12	6.70 %	180	0.19300	0.0129	0.6
		13	9.10 %	0	0.26432	0.0129	0.6
		14	5.70 %	0	0.16543	0.0129	0.6

Table 8-4. Composite Harmonics Verification (cont.)

Verification Tests for AC Voltage	Harmonic	Fundamental	Phase	Amplitude (V)	Specification (V)	Specification (deg)
	15	6.50 %	180	0.18880	0.0129	0.6
	16	5.00 %	180	0.14475	0.0129	0.6
	17	5.80 %	0	0.16659	0.0129	0.6
	18	4.40 %	0	0.12867	0.0129	0.6
	19	5.10 %	180	0.14905	0.0129	1.0
	20	4.00 %	180	0.11580	0.0129	1.0
	21	4.70 %	0	0.13486	0.0129	1.0
	22	3.60 %	0	0.10527	0.0129	1.0
	23	4.30 %	180	0.12313	0.0129	1.0
	24	3.30 %	180	0.09650	0.0129	1.0
	25	3.90 %	0	0.11328	0.0129	1.0
	26	3.10 %	0	0.08908	0.0129	1.0
	27	3.60 %	180	0.10489	0.0129	1.0
	28	2.90 %	180	0.08271	0.0129	1.0
	29	3.40 %	0	0.09766	0.0129	1.0
	30	2.70 %	0	0.07720	0.0129	1.0
	31	3.20 %	180	0.09136	0.0129	1.0
	32	2.50 %	180	0.07237	0.0129	1.0
	33	3.00 %	0	0.08582	0.0129	1.0
	34	2.40 %	0	0.06812	0.0129	1.0
	35	2.80 %	180	0.08092	0.0129	1.0
	36	2.20 %	180	0.06433	0.0129	1.0
	37	2.60 %	0	0.07654	0.0129	1.0
	38	2.10 %	0	0.06095	0.0129	1.0
	39	2.50 %	180	0.07262	0.0129	1.0
	40	2.00 %	180	0.05790	0.0129	1.0

**Table 8-4. Composite Harmonics Verification (cont.)**

Verification Tests for AC Voltage		Harmonic	Fundamental	Phase	Amplitude (V)	Specification (V)	Specification (deg)
<b>Range</b>	20.5 A	rms			5.80000	0.0216	
<b>Wave</b>	IECD	1	100.00 %		5.04200	0.0150	
<b>RMS Output</b>	5.8 A	3	46.90 %	180	2.36600	0.0150	0.6
<b>Frequency</b>	50 Hz	5	26.20 %	0	1.32200	0.0150	0.6
		7	13.80 %	180	0.69600	0.0150	0.6
		9	6.90 %	0	0.34800	0.0150	0.6
		11	4.80 %	180	0.24360	0.0150	0.6
		13	4.10 %	0	0.20612	0.0150	0.6
		15	3.50 %	180	0.17864	0.0150	0.6
		17	3.10 %	0	0.15763	0.0150	0.6
		19	2.80 %	180	0.14103	0.0150	1.0
		21	2.50 %	0	0.12760	0.0150	1.0
		23	2.30 %	180	0.11651	0.0150	1.0
		25	2.10 %	0	0.10719	0.0150	1.0
		27	2.00 %	180	0.09924	0.0150	1.0
		29	1.80 %	0	0.09250	0.0150	1.0
		31	1.70 %	180	0.08644	0.0150	1.0
		33	1.60 %	0	0.08120	0.0150	1.0
		35	1.50 %	180	0.07656	0.0150	1.0
		37	1.40 %	0	0.07242	0.0150	1.0
		39	1.40 %	180	0.06871	0.0150	1.0
<b>Range</b>	20.5 A	rms			9.50000	0.0290	
<b>Wave</b>	NRC 7030	1	100.00 %		8.51300	0.0185	
<b>RMS Output</b>	9.5 A	2	10.00 %	-115.5	0.85313	0.0185	0.6
<b>Frequency</b>	60 Hz	3	10.00 %	1.1	0.85313	0.0185	0.6
		4	10.00 %	-179.6	0.85313	0.0185	0.6
		5	10.00 %	13.3	0.85313	0.0185	0.6
		6	10.00 %	9.3	0.85313	0.0185	0.6
		7	10.00 %	73.5	0.85313	0.0185	0.6
		8	10.00 %	152.1	0.85313	0.0185	0.6
		9	10.00 %	-19.9	0.85313	0.0185	0.6
		10	10.00 %	-167.8	0.85313	0.0185	0.6

Table 8-4. Composite Harmonics Verification (cont.)

Verification Tests for AC Voltage	Harmonic	Fundamental	Phase	Amplitude (V)	Specification (V)	Specification (deg)
	11	10.00 %	85.9	0.85313	0.0185	0.6
	12	10.00 %	-37.3	0.85313	0.0185	0.6
	13	10.00 %	16.1	0.85313	0.0185	0.6
	14	10.00 %	-28.1	0.85313	0.0185	0.6
	15	10.00 %	94	0.85313	0.0185	0.6
	16	10.00 %	-173.4	0.85313	0.0185	1.0
	17	10.00 %	129.5	0.85313	0.0185	1.0
	18	10.00 %	-113.9	0.85313	0.0185	1.0
	19	10.00 %	37.6	0.85313	0.0185	1.0
	20	10.00 %	-52.3	0.85313	0.0185	1.0
	21	10.00 %	1.5	0.85313	0.0185	1.0
	22	10.00 %	14.3	0.85313	0.0185	1.0
	23	10.00 %	150.2	0.85313	0.0185	1.0
	24	10.00 %	7.1	0.85313	0.0185	1.0
	25	10.00 %	161.3	0.85313	0.0185	1.0

## Calibration

You must calibrate of the voltage and current outputs to get them to their nominal values for the Delta Amplitude output of the PQ option. This calibration must be done after the mainframe calibration with the procedure in the this manual. PQ calibration is done independently of the oscilloscope option calibration, and done before or after oscilloscope calibration.

PQ calibration has three sections:

- Normal ac voltage
- AUX ac current
- AUX ac voltage

The equipment necessary for each section is a subset of the equipment necessary for the 5522A mainframe. See the “Equipment Necessary for Verification and Calibration” section in Chapter 3 of this manual. Review the necessary equipment for each PQ function before you start the PQ calibration procedure.

To start the calibration procedure:

1. Push **SETUP**.
2. Push the **CAL** softkey.
3. Push the **CAL** softkey.
4. Push the **OPTION CAL** softkey.
5. Push the **PQ CAL** softkey.

If a different section is to be calibrated, push the **OPTIONS** then **NEXT SECTION** softkeys. In a section, each step shows the correct instrument connection and prompts you for measurement shown on the measurement device. To start the calibration remotely, send the command “CAL\_START PQ” through the host. (CAL\_START PQ is the only remote calibration command that is unique to the PQ.) Each time a calibration step is completed, “CAL\_NEXT <value>” must be sent to continue.

**Normal AC Voltage**

Measure ac voltage with the Fluke 5790A AC Measurement Standard. Type in the measured value into the Calibrator for each of the nominal values shown in Table 8-5.

**Table 8-5. Normal AC Volts**

Step	Calibrator Normal Output
1	30 mV
2	300 mV
3	3 V
4	30 V
5	300 V
6	1000 V

**AUX AC Current**

For nominal values of 300  $\mu$ A to 300 mA, measure the AC current with the Hewlett-Packard 3458A. For nominal values of 2 A and 10 A, use the A40 2 A and 20 A current shunts, respectively. You must do a dc characterization on these shunts before they can be used. DC characterization can be done with the 5522A, as long as the entire 5522A dc current calibration is done first. See “AC Current Calibration” in this manual.

The 5790A or 3458A can be used as the detector. A 20 A dc/ac shunt such as the Fluke Y5020 or MeasureTech EL-7520 can also be used for 2 A and 10 A outputs. DC characterization is not necessary for these two shunts. Type in the measured value into the Calibrator for each of the nominal values shown in Table 8-6.

**Table 8-6. AUX AC Current**

Step	Calibrator AUX Output
1	300 $\mu$ A
2	3 mA
3	30 mA
4	300 mA
5	2 A
6	2 A LCOMP ON
7	10 A
8	10 A LCOMP ON

### **AUX AC Voltage**

To calibrate the auxiliary AC voltage function, use the the normal AC voltage output procedure, but use the AUX HI and LO terminals on the Calibrator. The 5790A or 3458A can be used. Table 8-7 is a list of the calibration steps for AUX AC volts.

**Table 8-7. AUX AC Voltage**

<b>Step</b>	<b>Calibrator AUX Output</b>
1	300 mV
2	3 V
3	3 V