

## Type 1009AW Stainless Case Gauge with Bronze System



### FEATURES

- Patented PowerFlex™ movement
- All welded construction
- 1% full scale accuracy, ASME Grade 1A
- True Zero™ pointer indication
- NEW ventable plug
- NEW patent pending through-dial calibration
- NEW MSL helium leak tested to 1X10<sup>-6</sup> ATM -cc/sec
- Meets ASME B40.100 and EN837-1 standards
- RoHS compliant
- CRN approved
- 5 year limited warranty

Ashcroft is pleased to reintroduce the 1009AW Duralife® pressure gauge. This gauge has been upgraded with many new features outlined above while maintaining the tried and true performance and quality you have come to expect.

Duralife 1009AW gauges provide significant features and benefits. New features include a ventable plug that can be sealed or vented depending on your environment and a patent pending through-dial recalibration that reduces recalibration time.

The combination of features including the patented PowerFlex™ movement and optional PLUS!™ Performance dampening system in the Ashcroft Duralife 1009AW gauge is the finest gauge technology for vibration, shock and pulsation applications. Available in pressure ranges from vacuum to 1000 psi, including compound and metric ranges.

### PRODUCT SPECIFICATIONS

<b>Ashcroft</b>	
<b>Type No.:</b>	1009AW
<b>Sizes:</b>	2½", 3½"
<b>Case:</b>	304SS
<b>Ring:</b>	304SS polished bayonet
<b>Window:</b>	Polycarbonate
<b>Dial:</b>	Black figures on white background, aluminum
<b>Pointer:</b>	Friction adjust, black, aluminum
<b>Bourdon Tube:</b>	316L stainless steel C-Shaped (vacuum-600 psi and compound) Helical (1000psi)
<b>Socket:</b>	Bronze
<b>Movement:</b>	300 series stainless steel, PowerFlex, polyester segment, overload/underload stops
<b>Connections:</b>	¼ and ½ NPT, lower or lower back
<b>Ranges:</b>	Vac-1000psi and compound
<b>Accuracy:</b>	1% full scale; ASME Grade 1A
<b>Fill Plug:</b>	Ventable
<b>Protection:</b>	Nema 4X / IP65 plug sealed Nema 3 / IP54 plug vented
<b>Ambient Temperature</b>	-40°F to 200°F dry
<b>Limitations:</b>	+20°F to 150°F glycerin filled -40°F to 150°F silicone filled (based on standard polycarbonate window)
<b>OPTIONAL FEATURES</b>	
<b>Liquid fill:</b>	Glycerin, silicone, halocarbon (includes throttle plug)
<b>Dampening:</b>	PLUS!™ Performance (LL) (includes throttle plug)
<b>Window:</b>	Safety glass (SG)
<b>Pointer:</b>	Micrometer (MP)
<b>Connections:</b>	Metric and SAE
<b>Mounting:</b>	U-clamp (UC), Front flange (FF), Back flange (FW)
<b>Dials:</b>	Receiver ranges, refrigerant ranges; custom dials

### HOW TO ORDER (Typical example)

35 1009 AW (L) 02L XXX 100#

Dial Size: 2½" (25), 3½" (35) \_\_\_\_\_

Case Type: 1009 \_\_\_\_\_

Tube and Socket Material: 316L SS & Bronze \_\_\_\_\_

Liquid Filled: (glycerin) leave blank if dry \_\_\_\_\_

Connection Size: ¼ (01), ½ (02) \_\_\_\_\_

Connection Location: Lower (L), Lower Back (B) \_\_\_\_\_

Options: \_\_\_\_\_

Range: 0/100 psi \_\_\_\_\_

# Type 1009AW Stainless Case Gauge with Bronze System



## DIMENSIONS

**2 1/2" 1009 Lower and Back Connect**

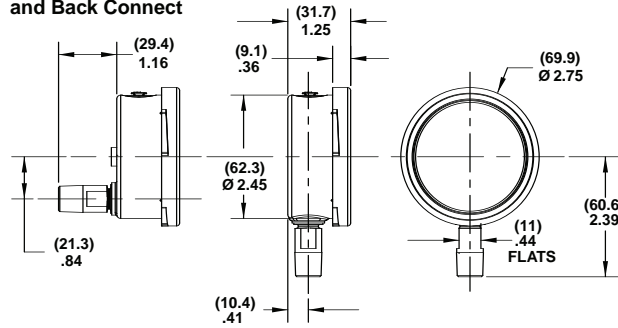

**3 1/2" 1009 Lower and Back Connect**

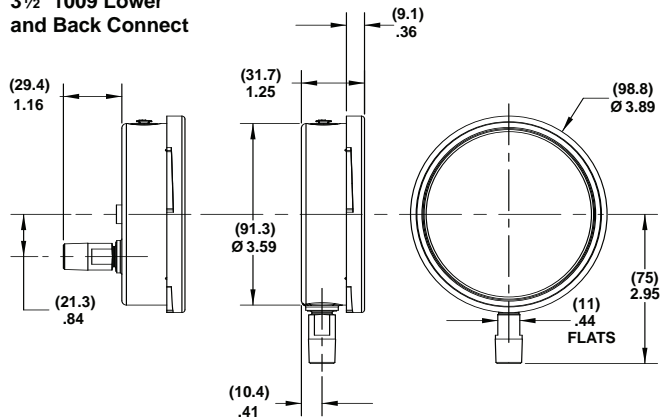

**2 1/2" 1009 Back Connect (XUC)**

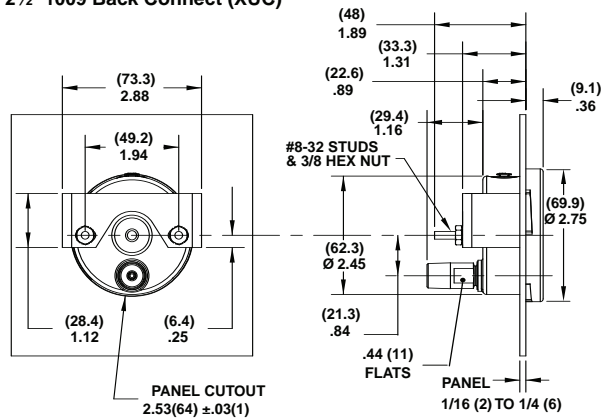

**3 1/2" 1009 Back Connect (XUC)**

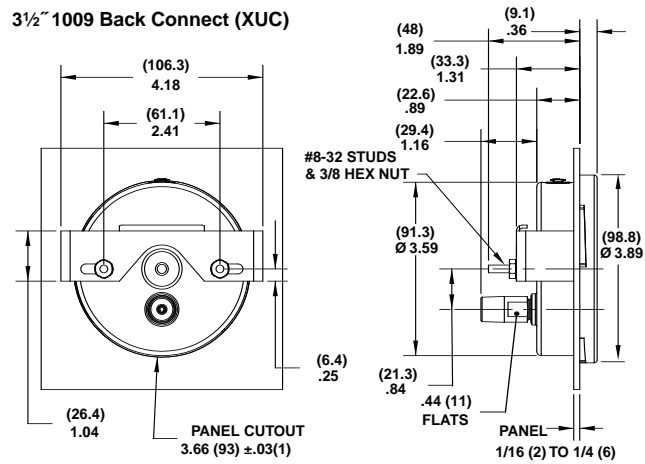

**2 1/2" 1009 Back Connect (XFF)**

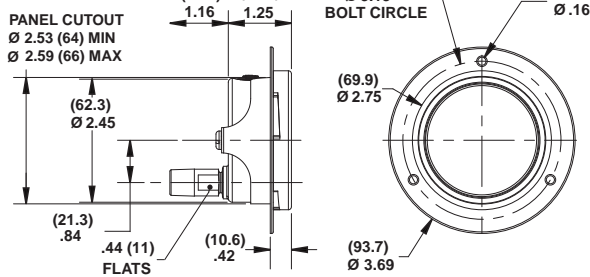

**3 1/2" 1009 Back Connect (XFF)**

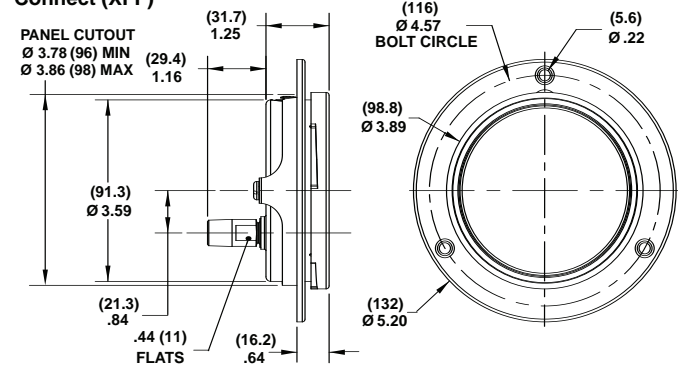

**2 1/2" 1009 Lower and Back Connect (XFW)**

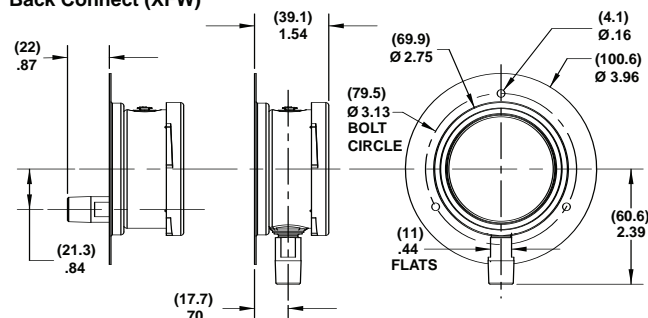

**3 1/2" 1009 Lower and Back Connect (XFW)**

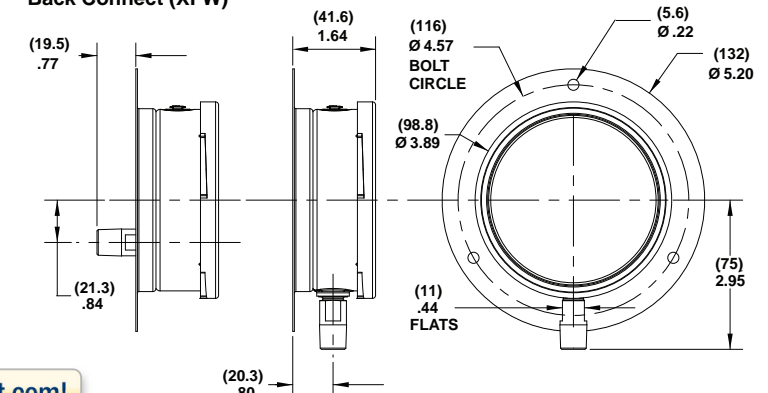

Visit us at [Transcat.com](http://Transcat.com)!

35 Vantage Point Drive // Rochester, NY 14624 // Call 1.800.800.5001