

Pomona®

Models 5787A & 5916A IEC 1010 Compliant Medium Alligator Clip

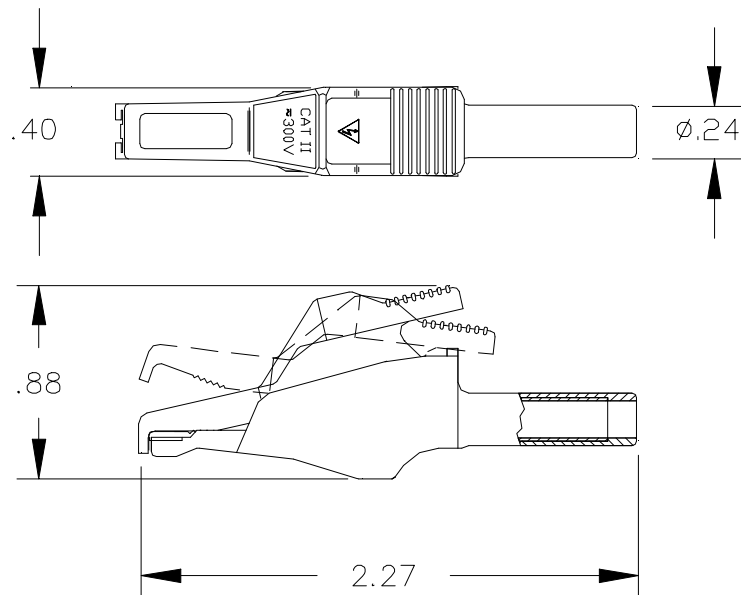

FEATURES:

- Redesigned to meet IEC 1010-2-031, the latest international safety standard for test accessories.
- Medium alligator jaw grips onto a test terminal up to 0.3" (7,6 mm) O.D.
- Thermoplastic body offers insulation protection.
- For added safety, the insulation material in UL94 V-O rated.
- Alligator clip features a 4 mm sheathed safety jack which interfaces to Pomona's Models 5907A, 5908A and 5909A Flexible Test Leads.

MATERIALS:

Body: Steel, Nickel Plated

Insulation: Polypropylene, Fire Retardant – UL94 V-O Rated

RATINGS:

IEC 1010-2-031

Operating Voltage: 300 VRMS, Cat II, P2

Current: 5 Amperes Max.

ORDERING INFORMATION: Model 5787A

5916A (Set of one black, one red)

5787A-*, * = Color, Standard Colors: -0 Black, -2 Red

Medium alligator clip is also included in many Pomona DMM Test Clips.

All dimensions are in inches. Tolerances (except noted): .xx = ±.02" (.51 mm), .xxx = ±.005" (.127 mm).

All specifications are to the latest revisions. Specifications are subject to change without notice.

Registered trademarks are the property of their respective companies.

Made in USA