

Pomona®

TRANSCAT

▶ Visit us at [Transcat.com!](http://Transcat.com)

35 Vantage Point Drive Rochester, NY 14624
Call 1.800.800.5001

Model 5299 Adapter 3 Lug Triaxial (F) To BNC (M)

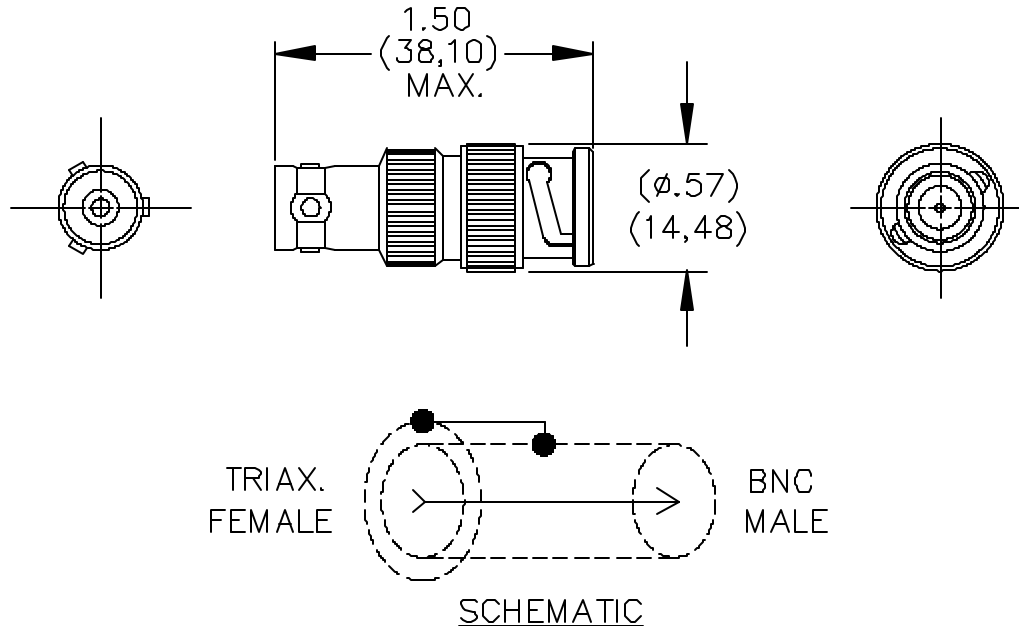

MATERIALS:

Body and Fittings – Gold Plated Brass, Male Contact – Gold Plated Brass, Female Contact – Gold Plated Beryllium Copper

Dielectric: Teflon

Finish: Body and Fittings: Tarnish resistant

Center & Intermediate Contacts: Gold Plated

Outer Contact: Tarnish resistant

Marking: “Pomona 5299”

RATINGS:

Operating Voltage: Shield/Earth: 30VAC/60VDC Max.

Frequency Range: DC to 500 MHz.

ORDERING INFORMATION: Model 5299

All dimensions are in inches and metric. All specifications are to the latest revisions. Specifications are subject to change without notice.
Registered trademarks are the property of their respective companies. Made in USA

TRANSCAT®

▶ Visit us at [Transcat.com!](http://Transcat.com)

35 Vantage Point Drive // Rochester, NY 14624 // Call 1.800.800.5001