



## JOFRA™ ATC Series Dry Block Temperature Calibrators

### ☐ Temperature Ranges

- ATC-155 -24° to 155°C (-11° to 311°F)
- ATC-320 50° to 320°C (122° to 608°F)
- ATC-650 50° to 650°C (122° to 1202°F)

### ☐ Dual-Zone Heating Block

- Ensures Temperature Homogeneity Throughout the Block
- Performance Equivalent to Liquid Temperature Bath

### ☐ Enhanced Accuracy and Stability

- Built-in External Reference Sensor
- MVI Circuitry Ensures Stability Despite Mains Supply Variations

### ☐ Universal Inputs

- Handles Multiple Type Temperature Sensors
- No Need for Multiple Instruments

### ☐ Automatic, Stand-Alone Calibration System

- Upload/Download Your Calibration Routines

## PRODUCT DESCRIPTION

The JOFRA™ ATC Series (Advanced Temperature Calibrators) combine the accuracy of laboratory calibrators with the speed and portability of dry block calibrators. They feature an improved design for optimum performance and temperature homogeneity throughout the block.

The ATC Series calibrators are available in three different temperature ranges and each version in two models, A and B.

The ATC-155 features improved Peltier elements that use a "Multi-Stage Technology" that improves the efficiency, and extends the life of the heating/cooling block.

The ATC-320 and ATC-650 models feature an innovative dual zone heating block designed for optimum performance and superior temperature homogeneity throughout the block. This new design delivers performance equivalent to a liquid temperature bath.

Each ATC dry-block calibrator may be used to perform fully automatic calibration routines without the use of an external computer. Use the computer for full upload and download capabilities. Units may also be supplied with an input for an external reference sensor and inputs for sensor under test. All ATC calibrators feature RS232 serial communication interface.

## FUNCTIONAL COMPARISON

Functions	ATC-155 A	ATC-155 B	ATC-320 A	ATC-320 B	ATC-650 A	ATC-650 B
Multi-Stage Peltier Heating Block	●	●				
Dual Zone Heating Block			●	●	●	●
MVI - Mains Variance Immunity			●	●	●	●
Stability Indicator	●	●	●	●	●	●
Automatic Step Function	●	●	●	●	●	●
Calibration Software Included	●	●	●	●	●	●
RS232 Communications	●	●	●	●	●	●
Display Resolution 0.01°	●	●	●	●	●	●
Output for "Calibrator is Stable"	●	●	●	●	●	●
Insert Storage Compartment	●	●	●	●	●	●
Downloading of Calibration Work Orders (Up to 20)		●		●		●
Uploading of Calibration Result to Personal Computers		●		●		●
Input for RTD, TC, V, mA, Switch		●		●		●
24VDC Transmitter Supply		●		●		●
Reference Sensor Input		●		●		●
Automatic Switch Test		●		●		●

**Precision Temperature Modulation (ATC-320/650)**

The ATC Series calibrators provide precision temperature calibration of sensors, whatever the type or format. This is accomplished through an innovative dual-zone heating block.

The ATC-320 and ATC-650 feature a dual-zone heating block. Each heating zone is independently controlled for precision temperature measurement. The homogeneity in the lower part of the block is close to that of a laboratory liquid bath. The lower zone ensures optimum heat dissipation throughout the entire block. The upper zone compensates for heat loss from the sensor-under-test and from the top of the block. This design also eliminates the need for insulating the sensors-under-test and makes it possible to calibrate liquid-filled and other mechanical sensors.

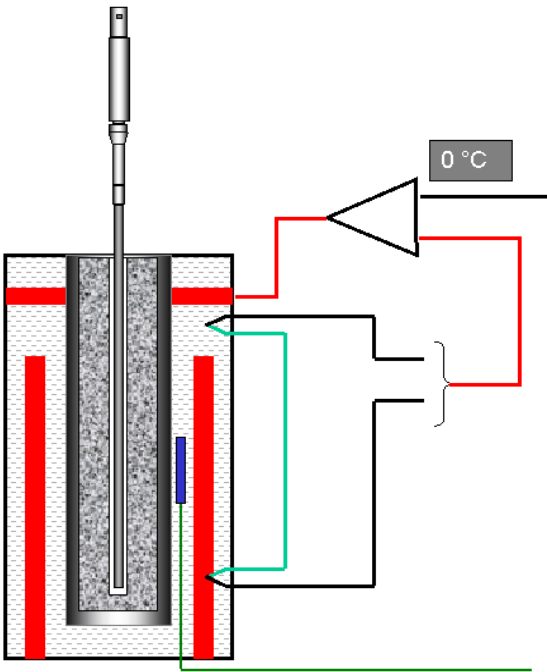

**Dual Heating Block Schematic**



**Optimum Temperature Stability (ATC-320/650)**

Unstable mains power supplies are a major contributor to on-site calibration inaccuracies. Traditional temperature calibrators often become unstable in production environments where large electrical motors, heating elements and other devices are periodically turned “on” or “off”. The cycling of power can cause the temperature regulator to perform inconsistently leading to both inaccurate readings and unstable temperatures. The ATC Series calibrators employ Mains Power Variance Immunity (MVI) which removes stability problems by identifying variations in the mains input voltage. MVI circuitry continuously monitors the input voltage and ensures that a constant energy flow to the heating block is supplied.

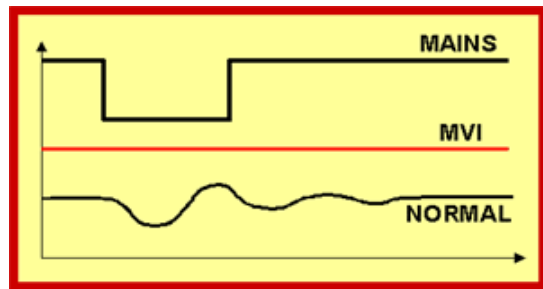

**Extended Heating Element Lifetime (ATC-155)**

AMETEK uses “Multi-Stage Technology” where two Peltier elements are stacked. This makes the ATC-155 more efficient and extends the lifetime of the elements. The power source (for the Peltier elements) is a variable current controlled DC power supply that reduces the self-heating effect of the elements and increases the temperature range.

Optimum thermal conditions are maintained by a new high efficiency insulation layer around the entire aluminum block. Heating and cooling is purely controlled through the electronic controlled Peltier elements.

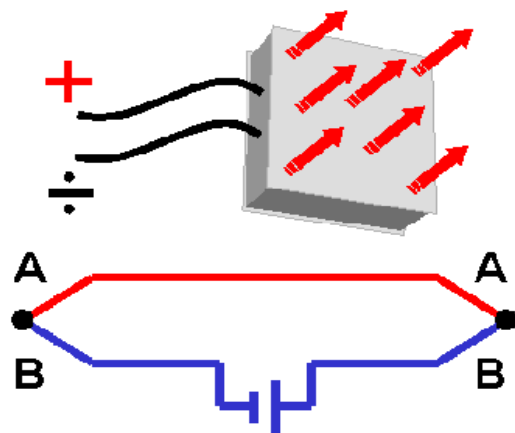

**Peltier Effect Schematic**

### Peltier Effect (ATC-155)

In 1834, Jean Peltier, a French physicist, found that an “opposite thermocouple effect” could be observed when an electric current was connected to a thermocouple. Heat would be absorbed at one of the junctions and discharged at the other junction. This effect is called the “PELTIER EFFECT”.

The practical Peltier element (Electronic Heating Pump) consists of many elements of semiconductor material that are connected electrically in series and thermally in parallel. These thermoelectric elements and their electrical interconnections are mounted between two ceramic plates. The plates serve to mechanically hold the overall structure together and to electrically insulate the individual elements from one another.

### Easy-To-Use, Intuitive Operation

All instrument controls are performed from the front panel. The heat source is positioned away from the panel which helps protecting the operator.

The ATC keyboard is equipped with five, positive feedback function keys. These correspond to the text in the display and change functionality based on instrument operations. There are also dedicated function keys with permanent functions. The easy-to-read, backlit display is large with a high contrast that is readable even in high ambient light conditions. The display is easily read from all angles and from a distance without parallax problems. The display also features icons which help identifying instrument conditions and operational steps.



### Set Temperature

The “Set Temperature” feature allows the user set the exact desired temperature with a resolution of 0.01°.

### Instrument Setups

The ATC Series allows the user to store up to nine (9) complete instrument setups. You may store all variables of information including temperature units, stability criteria, use of external reference sensor, resolution, sensor-under-test (SUT), conversion to temperature, display contrast, etc. The setup may be recalled at any time.

### High Accuracy (model B only)

ATC Series calibrators may be supplied with a built-in reference thermometer for use with an external probe. This feature allows one instrument to provide the freedom and flexibility to perform calibrations at the process site while maintaining a high accuracy.

A special 90° angled external reference sensor is designed to accommodate sensors with a transmitter head, top connector or having similar arrangements. The user can decide whether to read the built-in reference sensor or the more accurate angled reference sensor from the calibrator's large, easy-to-read LCD display. The external sensor and internal sensor are independent of one another. Downloading of reference sensor linearization is done via a personal computer.



### Special 90° angled reference sensor

### Set-Follows-True (Model B only)

Available on B Models only, the “SET-Follows TRUE” causes the instrument to tune in so that the temperature of the external reference “TRUE” is related to the desired “SET” temperature. This is used when it is critical that the temperature in the block should be matched to the desired temperature as measured with an accurate external reference sensor. This function is ideal for calibrating gas correctors or other custody transfer applications. It is extremely beneficial in the calculation process.

### Automatic Calibration Routines (Model B only)

The ATC Series model B is equipped with built-in converters (inputs) that measure virtually any type of temperature sensor including:

- thermostats
- resistance thermometers
- thermocouples
- transmitters
- milliamps (mA)
- voltage (V)

ATC Series calibrators can be user-programmed for completely automated temperature calibrations. Once the unit is set up, the instrument operates itself by performing the configured calibration routine. All calibration data are stored and is available for uploading for generating exact calibration certificates or reports.

**Simplified Calibration Documentation**

All ATC Series calibrators are provided with the AMECAL-TEMPERATURE software. This WINDOWS®-based software lets the user customize their calibration routines. The software is easy to use so you don't have to be a programmer to configure your calibration procedure. The software features prompts, menus and help functions that guide you through the configuration process.



Calibrations are collected and stored as "Work Orders" in a file and downloaded to the calibrator from a personal computer using a standard RS232 interface cable. The ATC calibrator stores the calibration procedure and may be taken out to the process site without the need of a personal computer. This allows your ATC calibrator to:

- Operate as a stand-alone instrument, using advanced calibration routines without the assistance of a personal computer on site;
- Prevent unauthorized changes to a calibration routine. Personnel who are not authorized to alter a calibration routine cannot do so.

Once all calibrations are completed, the data may be uploaded to the AMECAL-TEMPERATURE software for post-processing and printing of certificates. The calibration data collected may be stored on the personal computer for later recall or analysis.

The AMECAL-TEMPERATURE software supports all JOFRA dry-block calibrators equipped with an RS232 serial data interface, the JOFRA DTI -1000 reference thermometer and applications using liquid baths, ice point or other dry-block heat sources. Using the software's "SCENARIO" function, instruments may be combined in virtually any configuration.

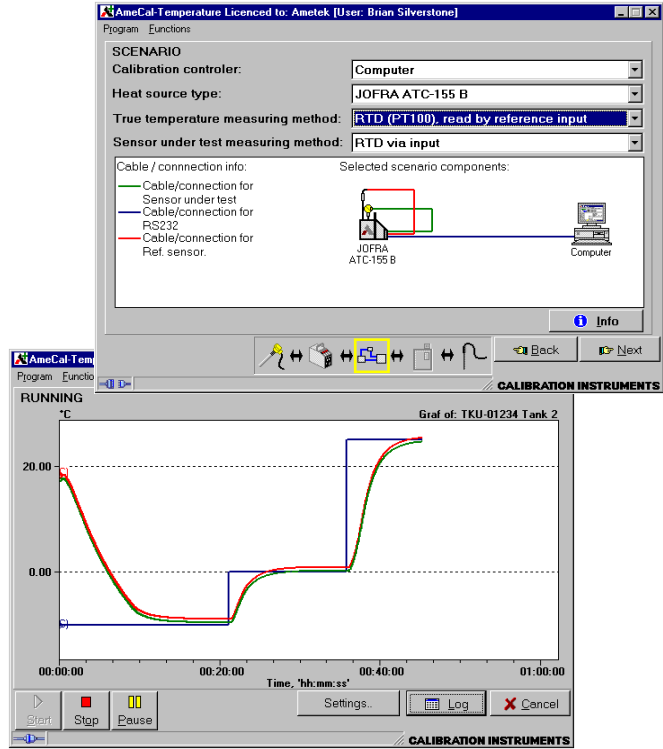

**As Found/As Left (model B only)**

The JOFRA ATC Series calibrator automatically handles "As Found/As Left" calibrations. The calibrator stores both results. The first performed calibration is "As Found" and the last performed calibration is the "As Left", regardless of the number of calibrations/adjustments that may have been made in between.

**Calibration (model B only)**

Users may perform or read the results of the downloaded calibration tasks directly from the instrument. When calibrating an indicating device, users can key in the results during or after the test. Using the "Calibration Info" function, the user can view the complete calibration task, including the "Scenario" before the calibration takes place.

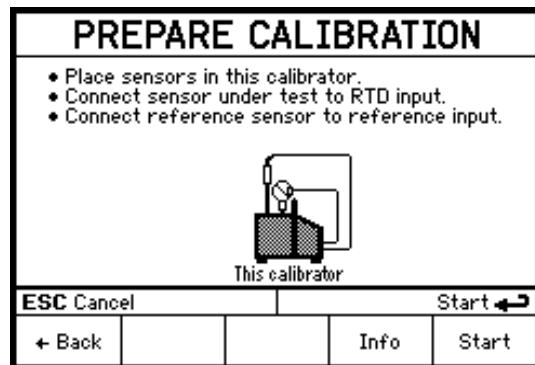

**SYNC Output**

An output is located directly on the front of the ATC calibrator. This output signals when the instrument is stable and may be used with ancillary devices including video recorder, digital camera or as an input to a data logging device. The SYNC output may be useful for automating and documenting your calibrations when calibrating reading devices.

**MAX Temperature**

Using the Setup menu, the user can select the maximum temperature limit. This function prevents the sensor under test from being destroyed by applying excessive temperatures. It also helps reduce drift resulting from long extended periods at a high temperature. This feature can be locked with an access code.

**Enhanced Stability**

A stability indicator shows when the ATC calibrator has reached the desired temperature and is stable. The user may change the stability criteria, external reference and the unit under test quickly and simply. The stability criteria is the user's security for a correct calibration. A count-down timer is displayed next to the temperature read-out.

STABILITY CRITERIA	
<b>Internal reference (READ)</b>	
Extended stability time: 0 min.	
<b>External reference (TRUE)</b>	
Stability interval: ± 0.03°C	
Stability time: 10 min.	
<b>Sensor under test (SENSOR)</b>	
Use stability criteria: No	
Stability interval: ± 0.03°C	
Stability time: 2 min.	
ESC Cancel <span style="float:right">Accept ←</span>	
Edit	

**Auto Stepping**

Up to 20 different temperature steps may be programmed including the hold time for each step. Upon completion of an Auto Step routine, the user can easily read the results for the sensor-under-test. Up to five (5) Auto Step results may be stored.

AUTO STEP SETUP				
 No. of steps: 5 Mode: One-way Hold time: 5 min	T1	0°C	T11	°C
	T2	100°C	T12	°C
	T3	200°C	T13	°C
	T4	300°C	T14	°C
	T5	400°C	T15	°C
	T6	°C	T16	°C
	T7	°C	T17	°C
	T8	°C	T18	°C
	T9	°C	T19	°C
	T10	°C	T20	°C
Back-space ←		Prev. field ▲	Next field ▼	

**Switch Test (Model B only)**

Users may perform a thermoswitch test and find "Open", "Closed" and the hysteresis (deadband) automatically. The instrument retains the last five tests. This information cannot be uploaded to a personal computer.

**PHYSICAL SPECIFICATIONS**

**Instrument Dimensions (L x W x H)**

352 x 156 x 360 mm  
 13.9 x 6.1 x 14.2 in

**Instrument Weight**

ATC-155A ..... 12.6 kg (27.8 lbs)  
 ATC-155B ..... 12.7 kg (28.0 lbs)

ATC-320-A ..... 10.1 kg (22.3 lbs)  
 ATC-320-B ..... 10.2 kg (22.5 lbs)

ATC-650-A ..... 12.0 kg (26.5 lbs)  
 ATC-650-B ..... 12.1 kg (26.7 lbs)

**Insert Dimensions**

Diameter ..... 30 mm (1.18 in)

ATC-155 Overall Length ..... 150 mm (5.91 in)  
 ATC-155 Immersion Depth ..... 160 mm (6.30 in)  
 (including the insulation plug)

ATC-320/650 Overall Length ..... 160 mm (6.30 in)  
 ATC-320/650 Immersion Depth ..... 150 mm (5.91 in)

**Weight of Non-Drilled Insert (Approximate)**

ATC-155 ..... 290 g (9 oz)  
 ATC-320/ATC-650 ..... 940 g (29.2 oz)

**Shipping Dimensions (L x W x H)**

Without Optional Carrying Case but with all accessories  
 570 x 235 x 440 mm  
 22.4 x 9.3 x 17.3 in

Including Optional Carrying Case  
 659 x 309 x 514 mm  
 26.0 x 12.2 x 20.2 in

**Shipping Weight**

Including Optional Carrying Case  
 ATC-155 ..... 22.7 kg (50.0 lbs)  
 ATC-320 ..... 20.7 kg (45.6 lbs)  
 ATC-650 ..... 22.6 kg (49.8 lbs)

**Serial Data Interface** ..... RS232C (9-pin Male)

**Operating Temperature** ..... 0° to 40°C (32° to 104°F)

**Storage Temperature** ..... -20 to 60°C (-4 to 140°F)

**Humidity** ..... 0 to 90% RH

**Protection Class** ..... IP-10

**CE Conformance**

EN61326-1 : 1997/A1:1998  
 EN61010-1 : 1993/A2:1995

## FUNCTIONAL SPECIFICATIONS

### Power Voltage

ATC-155/320 ... 115VAC (90-127V) 230VAC (180-254V)  
 ATC-650 ..... 115VAC (100-127V) 230VAC (200-254V)

### Power Frequency

45 - 65 Hz

### Power Consumption (Maximum)

ATC-155 ..... 200 VA  
 ATC-320/650 ..... 1150 VA

### Temperature Range

ATC-155  
 Maximum ..... 155°C (311°F)  
 Minimum @ ambient temp 0°C (32°F) ..... -40°C (-40°F)  
 Minimum @ ambient temp 23°C (73°F) ... -24°C (-11°F)  
 Minimum @ ambient temp 40°C (104°F) .. -12°C (10°F)

ATC-320 ..... 50° to 320°C (122° to 608°F)  
 ATC-650 ..... 50° to 650°C (122° to 1202°F)

### Resolution (User-Selectable)

All temperatures and inputs may be displayed with 1°, 0.1° or 0.01°

### Stability

ATC-155 ..... ±0.02°C (±0.04°F)  
 ATC-320 ..... ±0.02°C (±0.04°F)  
 ATC-650 ..... ±0.03°C (±0.06°F)  
 Measured after the stability indicator has been on for 10 minutes.  
 Measuring time is 10 minutes.

### Accuracy (Model B)

ATC-155 B ..... ±0.04°C (±0.07°F)  
 ATC-320 B ..... ±0.07°C (±0.13°F)  
 ATC-650 B ..... ±0.11°C (±0.20°F)  
 12 month period. Specification for the external reference probe and the reference input.

### Accuracy (Model A and B)

ATC-155 A+B ..... ±0.19°C (±0.34°F)  
 ATC-320 A+B ..... ±0.26°C (±0.47°F)  
 ATC-650 A+B ..... ±0.39°C (±0.70°F)  
 12 month period. Specification by the use of the internal reference.

### Radial Homogeneity (Difference Between Holes)

ATC-155 A+B ..... 0.02°C (0.04°F)  
 ATC-320 A+B ..... 0.01°C (0.02°F)  
 ATC-650 A+B ..... 0.05°C (0.09°F)

### Cooling Time

ATC-155  
 155° to 100°C (311° to 212°F) ..... 3 minutes  
 155° to 23°C (311° to 73°F) ..... 13 minutes  
 23° to -24°C (73° to -11°F) ..... 37 minutes  
 155° to -24°C (311° to -11°F) ..... 50 minutes

ATC-320  
 320° to 100°C (608° to 212°F) ..... 22 minutes  
 320° to 50°C (608° to 122°F) ..... 42 minutes

ATC-650  
 650° to 100°C (1202° to 212°F) ..... 43 minutes  
 650° to 50°C (1202° to 122°F) ..... 68 minutes

### Heating Time

ATC-155  
 -24° to 23°C (-11° to 73°F) ..... 4 minutes  
 23° to 155°C (73° to 311°F) ..... 23 minutes  
 -24° to 155°C (-11° to 311°F) ..... 27 minutes

ATC-320  
 50° to 320°C (122° to 608°F) ..... 7 minutes

ATC-650  
 50° to 650°C (122° to 1202°F) ..... 27 minutes

### Time to Stability (Approximate)

Time ..... 10 minutes

### Sync. Output (Dry Contact)

Switching voltage ..... Maximum 30 VDC  
 Switching current ..... Maximum 100 mA

### Transmitter Supply (Model B Only)

Output voltage ..... 24VDC ±10%  
 Output current ..... Maximum 25 mA

### Transmitter Input mA (Model B Only)

Range: ..... 0 to 24 mA  
 Accuracy (12 months) ..... ±0.01% Rdg. +0.015% F.S.

### Voltage Input VDC (Model B Only)

Range: ..... 0 to 12VDC  
 Accuracy (12 months) ..... ±0.005% Rdg. +0.015% F.S.

### Switch Input (Model B Only)

Switch Dry Contacts  
 Test voltage ..... Maximum 5 VDC  
 Test current ..... Maximum 2.5 mA

### RTD Reference Input (Model B Only)

Type ..... 4-wire RTD with true ohm measurements<sup>1</sup>  
 F.S. (Full Scale) ..... 350 Ohm  
 Accuracy (12 months) ..... 0.003% Rdg. + 0.002% F.S.

RTD Type	Temperature		12 Months	
	°C	°F	°C	°F
Pt100 Reference	-50	-58	±0.024	±0.042
	0	32	±0.026	±0.046
	155	311	±0.032	±0.057
	320	592	±0.038	±0.068
	500	932	±0.047	±0.084
	700	1292	±0.056	±0.101

Note<sup>1</sup>: As found on the JOFRA DTI-1000 Reference Thermometer (eliminates the error from induced thermoelectrical voltages)

**Thermocouple Input (Model B Only)**

Range .....  $\pm 78$  mV  
 F.S. (Full Scale) ..... 78 mV  
 Accuracy (12 months) ..... 0.01% Rdg. + 0.005% F.S.

TC Type	Temperature		12 Months	
	°C	°F	°C	°F
<b>E</b>	-50	-58	$\pm 0.08$	$\pm 0.14$
	0	32	$\pm 0.07$	$\pm 0.12$
	155	311	$\pm 0.07$	$\pm 0.12$
	320	592	$\pm 0.08$	$\pm 0.14$
	650	1202	$\pm 0.11$	$\pm 0.20$
	1000	1832	$\pm 0.15$	$\pm 0.28$
<b>J</b>	-50	-58	$\pm 0.10$	$\pm 0.17$
	0	32	$\pm 0.08$	$\pm 0.14$
	155	311	$\pm 0.08$	$\pm 0.15$
	320	592	$\pm 0.10$	$\pm 0.18$
	650	1202	$\pm 0.12$	$\pm 0.19$
	1200	2192	$\pm 0.19$	$\pm 0.34$
<b>K</b>	-50	-58	$\pm 0.11$	$\pm 0.20$
	0	32	$\pm 0.10$	$\pm 0.18$
	155	311	$\pm 0.11$	$\pm 0.20$
	320	592	$\pm 0.12$	$\pm 0.22$
	650	1202	$\pm 0.16$	$\pm 0.28$
	1372	2502	$\pm 0.28$	$\pm 0.50$
<b>T</b>	-50	-58	$\pm 0.12$	$\pm 0.22$
	0	32	$\pm 0.10$	$\pm 0.18$
	155	311	$\pm 0.09$	$\pm 0.16$
	320	592	$\pm 0.09$	$\pm 0.17$
	400	752	$\pm 0.10$	$\pm 0.17$
	<b>R</b>	-50	-58	$\pm 1.31$
0		32	$\pm 0.78$	$\pm 1.40$
155		311	$\pm 0.50$	$\pm 0.90$
320		592	$\pm 0.42$	$\pm 0.75$
650		1202	$\pm 0.41$	$\pm 0.74$
1760		3200	$\pm 0.50$	$\pm 0.90$
<b>S</b>	-50	-58	$\pm 0.98$	$\pm 1.77$
	0	32	$\pm 0.78$	$\pm 1.40$
	155	311	$\pm 0.50$	$\pm 0.90$
	320	592	$\pm 0.46$	$\pm 0.83$
	650	1202	$\pm 0.45$	$\pm 0.81$
	1768	3214	$\pm 0.52$	$\pm 0.94$
<b>N</b>	-50	-58	$\pm 0.16$	$\pm 0.29$
	0	32	$\pm 0.15$	$\pm 0.27$
	155	311	$\pm 0.14$	$\pm 0.24$
	320	592	$\pm 0.14$	$\pm 0.25$
	650	1202	$\pm 0.16$	$\pm 0.28$
	800	1472	$\pm 0.17$	$\pm 0.31$
<b>XK</b>	-50	-58	$\pm 0.07$	$\pm 0.13$
	0	32	$\pm 0.06$	$\pm 0.11$
	155	311	$\pm 0.06$	$\pm 0.12$
	320	592	$\pm 0.07$	$\pm 0.13$
	650	1202	$\pm 0.11$	$\pm 0.19$
	800	1472	$\pm 0.12$	$\pm 0.22$
<b>U</b>	-50	-58	$\pm 0.12$	$\pm 0.21$
	0	32	$\pm 0.10$	$\pm 0.18$
	155	311	$\pm 0.09$	$\pm 0.17$
	320	592	$\pm 0.09$	$\pm 0.17$
	600	1112	$\pm 0.10$	$\pm 0.19$

If automatic cold junction compensation is used, the specification for CJ is  $\pm 0.40^\circ\text{C}$  ( $\pm 0.72^\circ\text{F}$ ).

**RTD Input (Model B Only)**

Type of RTDs ..... 2-, 3- or 4-wire  
 F.S. (Range) ..... 350 Ohm or 2900 Ohm  
 Accuracy (12 months) ..... 0.005% Rdg. + 0.005% F.S.

RTD Type	Temperature		12 Months	
	°C	°F	°C	°F
<b>Pt1000</b>	-50	-58	$\pm 0.046$	$\pm 0.083$
	0	32	$\pm 0.050$	$\pm 0.090$
	155	311	$\pm 0.061$	$\pm 0.110$
	320	592	$\pm 0.071$	$\pm 0.127$
	500	932	$\pm 0.087$	$\pm 0.156$
	<b>Pt500</b>	-50	-58	$\pm 0.083$
0		32	$\pm 0.087$	$\pm 0.157$
155		311	$\pm 0.100$	$\pm 0.180$
320		592	$\pm 0.111$	$\pm 0.200$
500		932	$\pm 0.130$	$\pm 0.235$
<b>Pt100</b>		-50	-58	$\pm 0.054$
	0	32	$\pm 0.058$	$\pm 0.104$
	155	311	$\pm 0.069$	$\pm 0.124$
	320	592	$\pm 0.079$	$\pm 0.142$
	650	1202	$\pm 0.106$	$\pm 0.191$
	700	1292	$\pm 0.112$	$\pm 0.202$
<b>Pt50</b>	-50	-58	$\pm 0.098$	$\pm 0.176$
	0	32	$\pm 0.103$	$\pm 0.185$
	155	311	$\pm 0.116$	$\pm 0.209$
	320	592	$\pm 0.128$	$\pm 0.230$
	650	1202	$\pm 0.161$	$\pm 0.290$
	700	1292	$\pm 0.169$	$\pm 0.303$

All input specifications apply with the calibrator's dry block running at the respective temperature (stable plus additional 20 minute period). Where the input measuring range is out of the calibrator's range, the SET temperature is either MIN or MAX.

**EA-10/13 GUIDELINE**

EA means European Accreditation. The purpose of this organisation is to maintain and develop multilateral agreements within member and non-member accreditation bodies to achieve universal acceptance of accredited certificates and reports and interchange of technical knowledge among the countries.

EA has given birth to a new "Guideline on the Calibration of Temperature Block Calibrators". Including a complete uncertainty budget. Publication reference is EA-10/13.

Besides measuring absolute temperature by representative set-points, the calibrator must also be investigated for the following: Axial temperature homogeneity, Temperature difference between the borings, Influence upon the temperature in the measurement zone due to different loading, Stability with time and Temperature deviation due to heat conduction.

AMETEK CALIBRATION INSTRUMENTS is convinced that This guideline will become the standard of how to specify/qualify a Dry Block Temperature Calibrator in the future. The ATC series is already specified according to this guideline in a special document.

## ORDERING INFORMATION

### MODEL ATC SERIES DRY BLOCK TEMPERATURE CALIBRATORS

**Order Number Description**

<b>Base Model Number- 1st thru 7th Characters</b>	
ATC155A	ATC-155 Series, -24° to 155°C (-11° to 311°F), Model A
ATC155B	ATC-155 Series, -24° to 155°C (-11° to 311°F), Model B
ATC320A	ATC-320 Series, 50° to 320°C (122° to 608°F), Model A
ATC320B	ATC-320 Series, 50° to 320°C (122° to 608°F), Model B
ATC650A	ATC-650 Series, 50° to 650°C (122° to 1202°F), Model A
ATC650B	ATC-650 Series, 50° to 650°C (122° to 1202°F), Model B

<b>Power Supply- Size- 8th thru 10th Characters</b>	
115	115VAC, 50/60Hz
230	230VAC, 50 Hz

<b>Mains Power Cable Type- 11th Character</b>	
A	EUROPEAN, 230V,
B	USA, 115V
C	UK, 240V
D	SOUTH AFRICA, 220V
E	ITALY, 220V
F	AUSTRALIA, 240V
G	DENMARK, 230V
H	SWITZERLAND, 220V
I	ISRAEL, 230V

**Insert Type and Size- 12th thru 14th Characters**

003	Metric, Pre-drilled, 3 mm
004	Metric, Pre-drilled, 4 mm
005	Metric, Pre-drilled, 5 mm
006	Metric, Pre-drilled, 6 mm
008	Metric, Pre-drilled, 8 mm
009	Metric, Pre-drilled, 9 mm
010	Metric, Pre-drilled, 10 mm
011	Metric, Pre-drilled, 11 mm
012	Metric, Pre-drilled, 12 mm
013	Metric, Pre-drilled, 13 mm
014	Metric, Pre-drilled, 14 mm
015	Metric, Pre-drilled, 15 mm
016	Metric, Pre-drilled, 16 mm
125	Inch, Pre-drilled, 1/8 in
187	Inch, Pre-drilled, 3/16 in
025	Inch, Pre-drilled, 1/4 in
312	Inch, Pre-drilled, 5/16 in
375	Inch, Pre-drilled, 3/8 in
437	Inch, Pre-drilled, 7/16 in
562	Inch, Pre-drilled, 9/16 in
625	Inch, Pre-drilled, 5/8 in
M01	Metric, Multi-Holed, No. 1 (5 x 4 mm)
M02	Metric, Multi-Holed, No. 2 (5 x 6 mm, 1 x 4 mm)
M03	Metric, Multi-Holed, No. 3 (8 x 3 mm, 1 x 6 mm, 1 x 4 mm)
M04	Metric, Multi-Holed, No. 4 (1 x 3 mm, 1 x 4 mm, 1 x 5 mm, 2 x 6 mm, 1 x 9 mm)
M05	Inch, Multi-Holed, No. 5 (5 x 1/4 in and 1 x 4 mm)
M06	Inch, Multi-Holed, No. 6 (1 x 1/8 in, 1 x 3/16 in, 2 x 1/4 in, 1 x 3/8 in, 1 x 4 mm)

XXX Customer Special

<b>Options- 15th thru 17th Characters</b>	
A	Basic Accessory Kit
C	Carrying Case
E	Extended Accessory Kit, English
M	Extended Accessory Kit, Metric
R	90° Angled Reference Probe, with Accredited Certificate
S	90° Angled Reference Probe, No Certificate
X	Not Used

**ATC320B 115 B 025ACR**

**Sample Order Number**

ACT-320-B Series Dry Block Calibrator, 115VAC power with USA Power Cord and Pre-drilled 1/4-inch Insert. Includes Basic Accessory Kit, Carrying Case and Reference probe.



## STANDARD DELIVERY

### ATC-155, ATC-320 and ATC-650

Model A and B instruments contain the following standard items:

- ATC Dry Block Calibrator. (User Specified)
- Mains Power Cable (User Specified)
- Traceable Certificate - Temperature Performance
- Insert (User Specified)
- 3 Pcs. Insulation plugs for 6, 10, 16 mm sensors (ATC-155 only)
- Tool for Insertion tubes
- RS-232 Cable
- Software, AMECAL-TEMPERATURE
- Software, AMETRIM-ATC to adjust the ATC Series Instruments
- Users' Manual (Multi-Language)
- Reference Manual (English)

Model B instruments contain the following extra items:

- Test Cables (2x Red, 2x Black)
- Traceable Certificate - Input Performance

## COMPUTER REQUIREMENTS

### AMECAL-TEMPERATURE and AMETRIM-ATC

Listed are the minimum hardware requirements needed for running the AMECAL-TEMPERATURE calibration software and the AMETRIM-ATC adjusting software:

- INTEL™ 486 processor (PENTIUM™ 200 MHz recommended)
- 16 MB RAM (32 MB recommended)
- 40 MB free disk space on hard disk prior to installation
- Standard VGA (640x480, 16 colors) compatible screen (800x600 256 colors recommended)
- CD-ROM drive for installation of the program
- 1 or 2 free RS232 serial ports, depending on configuration

## CALIBRATION ACCESSORY KITS

Calibration Kits are available which contain various supplies required for a complete calibration system. These kits may be ordered with the instrument as an option or may be ordered separately. Three kits are available.

### Basic Calibration Kit

This kit contains a heat protection shield, cleaning brushes (4 mm, 6 mm and 8 mm), undrilled inserts with 4 mm reference hole (3 pcs.) and a Self-Drilling Guide for Inserts.

### Extended Calibration Kits

Two extended calibration kits are available (Metric and Inches). Both kits contain a heat protection shield, assorted cleaning brushes (3 pcs.), multi-hole insert no. 4 or 6 (ATC-155 kits includes multi-hole insulation plug), undrilled inserts with 4 mm reference hole (3 pcs.) and a Self-Drilling Guide for Inserts.



### ATC-155 SERIES CALIBRATION ACCESSORY KITS

PART NO.	DESCRIPTION
122833	Basic Calibration Accessory Kit
122835	Extended Calibration Accessory Kit (Metric)
122837	Extended Calibration Accessory Kit (Inches)

### ATC-320 AND ATC-650 SERIES CALIBRATION ACCESSORY KITS

PART NO.	DESCRIPTION
122834	Basic Calibration Accessory Kit
122836	Extended Calibration Accessory Kit (Metric)
122838	Extended Calibration Accessory Kit (Inches)

**INSERTS-UNDRILLED**

**ATC-155 SERIES**

PART NO.	DESCRIPTION
122720	5 Pack, Undrilled Insertion Tubes
122722	5 Pack, Undrilled Insertion Tubes + 4 mm Hole for Reference Probe

**ATC-320 AND ATC-650 SERIES**

PART NO.	DESCRIPTION
122719	5 Pack, Undrilled Insertion Tubes
122721	5 Pack, Undrilled Insertion Tubes + 4 mm Hole for Reference Probe

**INSERTS-PRE-DRILLED-METRIC**

**ATC-155 SERIES**

PART NO.	SIZE
105623	3 mm
105625	4 mm
105627	5 mm
105629	6 mm
105631	7 mm
105633	8 mm
105635	9 mm
105637	10 mm
105639	11 mm
105641	12 mm
105643	13 mm
105645	14 mm
105647	15 mm
105649	16 mm

**ATC-320 SERIES**

PART NO.	SIZE
105622	3 mm
105624	4 mm
105626	5 mm
105628	6 mm
105630	7 mm
105632	8 mm
105634	9 mm
105636	10 mm
105638	11 mm
105640	12 mm
105642	13 mm
105644	14 mm
105646	15 mm
105648	16 mm

**ATC-650 SERIES**

PART NO.	SIZE
105622	3 mm
105624	4 mm
105626	5 mm
105628	6 mm
105630	7 mm
105632	8 mm
105634	9 mm
105636	10 mm
105638	11 mm
105640	12 mm
105642	13 mm
105644	14 mm
105646	15 mm
105648	16 mm

Note: All inserts (metric and inches) are supplied with a hole for the 4 mm OD Reference Probe.

**INSERTS-MULTI-HOLE-METRIC**

**ATC-155 SERIES**

PART NO.	INSERT NO.
122751	No. 1
122753	No. 2
122755	No. 3
122757	No. 4

**ATC-320 SERIES**

PART NO.	INSERT NO.
122750	No. 1
122752	No. 2
122754	No. 3
122756	No. 4

**ATC-650 SERIES**

PART NO.	INSERT NO.
122750	No. 1
122752	No. 2
122754	No. 3
122756	No. 4

Note: All Multi-hole inserts (metric and inches) for ATC-155 are supplied with a matching insulation plug.

**INSERTS-MULTI-HOLED-METRIC LAYOUTS**

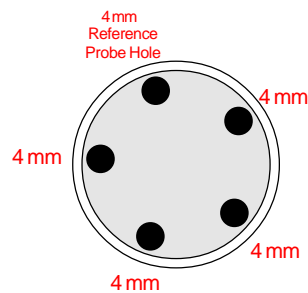

Multi-Hole No. 1  
 P/N 122750  
 P/N 122751 (ATC-155)

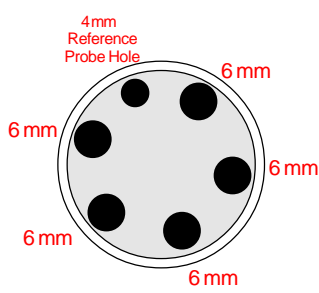

Multi-Hole No. 2  
 P/N 122752  
 P/N 122753 (ATC-155)

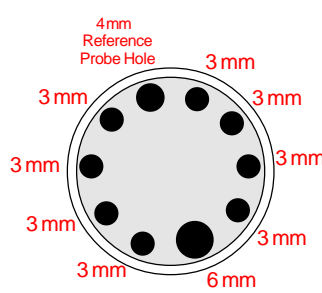

Multi-Hole No. 3  
 P/N 122754  
 P/N 122755 (ATC-155)

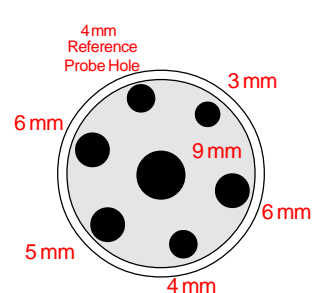

Multi-Hole No. 4  
 P/N 122756  
 P/N 122757 (ATC-155)

**INSERTS- UNDRILLED**

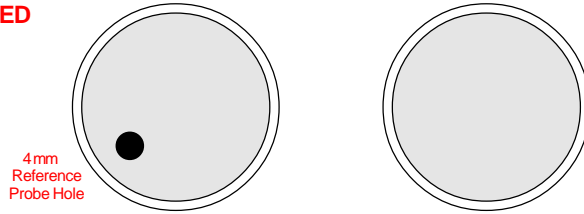

**General Insert description**

All inserts for ATC-155 are made of aluminum  
 All inserts for ATC-320 and ATC-650 are made of brass.

All specifications about hole size are referring to the outer diameter of the sensor-under-test.  
 The correct clearance size is applied in all pre-drilled inserts

**INSERTS- PRE-DRILLED-INCHES**

**ATC-155 SERIES**

PART NO.	SIZE
105677	1/8 in
105679	3/16 in
105681	1/4 in
105683	5/16 in
105685	3/8 in
105687	7/16 in
105689	1/2 in
105691	9/16 in
105693	5/8 in

**ATC-320 SERIES**

PART NO.	SIZE
105676	1/8 in
105678	3/16 in
105680	1/4 in
105682	5/16 in
105684	3/8 in
105686	7/16 in
105688	1/2" in
105690	9/16 in
105692	5/8 in

**ATC-650 SERIES**

PART NO.	SIZE
105676	1/8 in
105678	3/16 in
105680	1/4 in
105682	5/16 in
105684	3/8 in
105686	7/16 in
105688	1/2 in
105690	9/16 in
105692	5/8 in

Note: All inserts (metric and inches) are supplied with a hole for the 4 mm OD Reference Probe.

**INSERTS- MULTI-HOLE-INCHES**

**ATC-155 SERIES**

PART NO.	INSERT NO.
122759	No. 5
122761	No. 6

**ATC-320 SERIES**

PART NO.	INSERT NO.
122758	No. 5
122760	No. 6

**ATC-650 SERIES**

PART NO.	INSERT NO.
122758	No. 5
122760	No. 6

Note: All Multi-hole inserts (metric and inches) for ATC-155 are supplied with a matching insulation plug.

**INSERTS- MULTI-HOLED-IMPERIAL LAYOUTS**

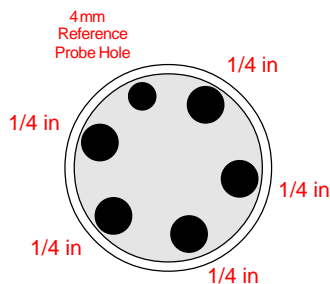

**Multi-Hole No. 5**  
 P/N 122758  
 P/N 122759 (ATC-155)

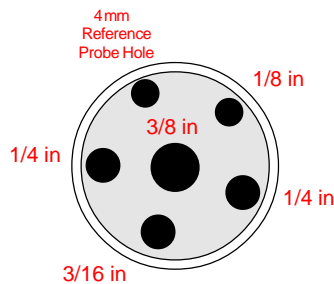

**Multi-Hole No. 6**  
 P/N 122758  
 P/N 122751 (ATC-155)

## ACCESSORIES

PART NO.	DESCRIPTION
105446	ATC Series, Reference Manual
105447	ATC Series, User Manual
105805	Carrying Case
122832	Cleaning Brush, 4 mm (3/Pkg)
60F174	Cleaning Brush, 6 mm (3/Pkg)
122822	Cleaning Brush, 8 mm (3/Pkg)
60D711+712	Connector, Lemo (Male) for Reference input Cable (4.3 to 5.1 mm diameter)
122771	Connector, Mini Jack, for "stable" relay output
60F135	Mains Cable, 115V, USA, Type B
60F139	Mains Cable, 220V, Australia, Type F
60F138	Mains Cable, 220V, Italy, Type E
60F137	Mains Cable, 220V, South Africa, Type D
60F141	Mains Cable, 230V, Denmark, Type G
60F140	Mains Cable, 230V, Europe, Type A
60F143	Mains Cable, 230V, Israel, Type I
60F142	Mains Cable, 230V, Switzerland, Type H
60F136	Mains Cable, 240V, UK, Type C
122823	Reference Input Cable, Lemo to Banana
122801	Reference Probe Cable, Lemo to Lemo (0.5 m)
75-PT100-90DEG	Reference Probe, with Accredited Certificate
65-PT100-90DEG	Reference Probe, No Certificate
105366	RS232 Cable
104203	Test Cable Set (Model B Only)
105496	Heat Shield
120519	Thermocouple, Type Cu-Cu, Male Plug
120517	Thermocouple, Type K, Male Plug
120514	Thermocouple, Type N, Male Plug
120515	Thermocouple, Type T, Male Plug
60F170	Tool for Insertion Tube
105810	Insulation Plug (ATC-155 Series Only) 3 pcs. for 6 mm (1/4 in), 10 mm (3/8 in), 16 mm (5/8 in)
105813	AMECAL-TEMPERATURE Software

## Accessories

An external heat shield is available and may be placed on top of the calibrator to reduce the hot air stream around the sensor under test. This is especially important for testing thermocouples having head-mounted transmitters with cold-junction compensation.



The optional protective carrying case helps ensure safe transportation and storage of the instrument and all associated equipment,

