

# Pomona®

## Models 5907A, 5908A & 5909A Flexible DMM Test Lead Set With Sheathed Style Banana Plugs

### MODEL 5907A

IDEAL FOR HAND HELD MULTI-METERS

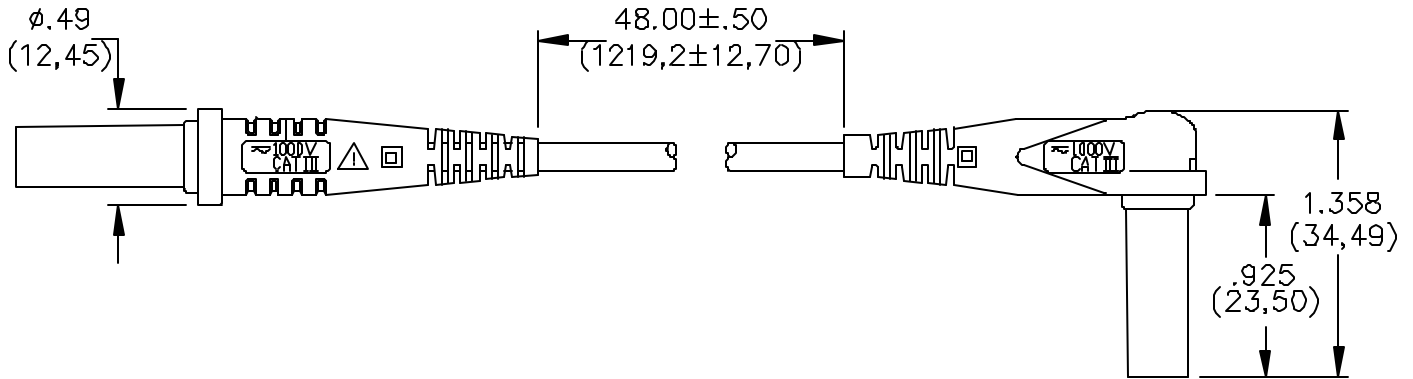

### MODEL 5908A

IDEAL FOR BENCH MULTI-METERS

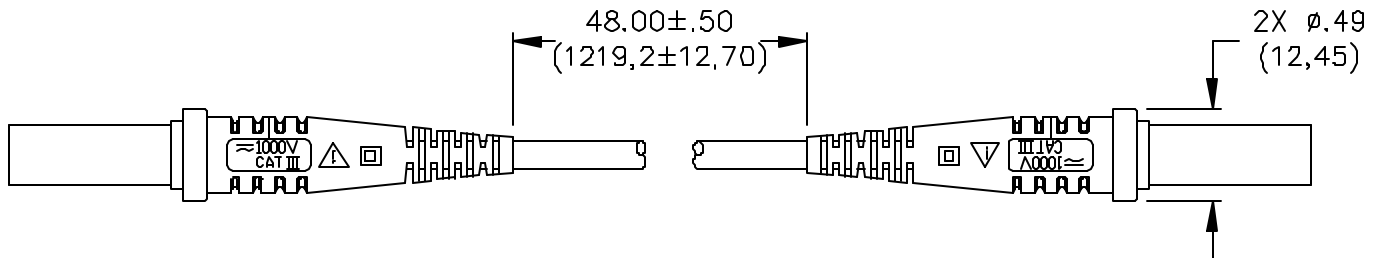

### MODEL 5909A

IDEAL FOR SPECIAL RIGHT ANGLE ACCESS APPLICATIONS

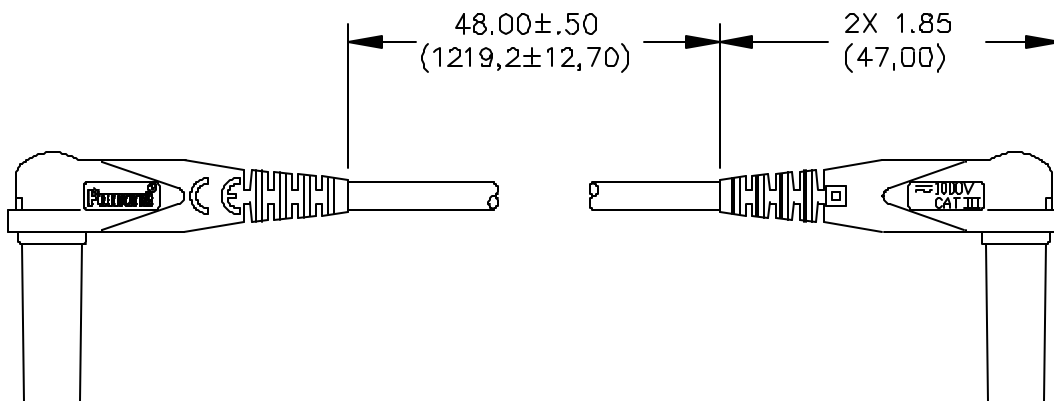

All dimensions are in inches. Tolerances (except noted):  $.xx = \pm .02$ " (.51 mm),  $.xxx = \pm .005$ " (.127 mm).

All specifications are to the latest revisions. Specifications are subject to change without notice.

Registered trademarks are the property of their respective companies. Made in USA

### FEATURES:

- Flexible test lead sets are a perfect interface for the most popular multimeters configured with 4 mm sheathed safety jacks, including Fluke, H-P, Tektronix and Wavetek.
- Redesigned Test leads comply to IEC 1010-2-31, which is the latest international safety standard for test accessories.
- For added safety, the body mold material is fire retardant Polypropylene, V-2 rated.
- Plug and housing are molded directly to the cable in an integral one piece design and the wire is double crimped for a long lasting connection.
- Multi-leaf banana spring material is beryllium copper, nickel plated for extended insertion cycle life and low contact resistance.
- High strand count silicone insulated wire offers excellent flexibility and high temperature resistance.
- Test leads can mate to a broad assortment of Pomona probes, alligators, spade lugs, etc.

### MATERIALS:

Plug Body: Brass, Nickel Plated

Spring: Beryllium Copper, Nickel Plated

Insulator: Polypropylene Fire Retardant - V-2 Rated

Wire: 18 AWG, 65 x 36 Tinned Copper Strand

Insulation: Silicone, O.D. 0.144" Nom.

### RATINGS:

IEC 1010 2-031, Category III, P2 Compliant

Operating Temperature: 80°C (176°F) Max.

Operating Voltage: 1,000 VRMS/DC Max.

Current: 10 Amperes Max.

### ORDERING INFORMATION:

**5907A** - Right Angle to Straight Banana Plug Flexible Test Lead Set (one black and one red)

**5908A** - Straight to Straight Banana Plug Flexible Test Lead Set (one black and one red)

**5909A** - Right Angle to Right Angle Banana Plug Flexible Test Lead Set (one black and one red)

Pomona Flexible Test Leads are also included in many Pomona Test Accessory Kits.

All dimensions are in inches. Tolerances (except noted): .xx = ±.02" (.51 mm), .xxx = ± .005" (.127 mm).

All specifications are to the latest revisions. Specifications are subject to change without notice.

Registered trademarks are the property of their respective companies. Made in USA