

Pomona®

TRANSCAT®

▶ Visit us at [Transcat.com!](http://Transcat.com)

35 Vantage Point Drive Rochester, NY 14624
Call 1.800.800.5001

Model 5678 SMD Test Tweezer® Leads To Sleeved Banana Plugs

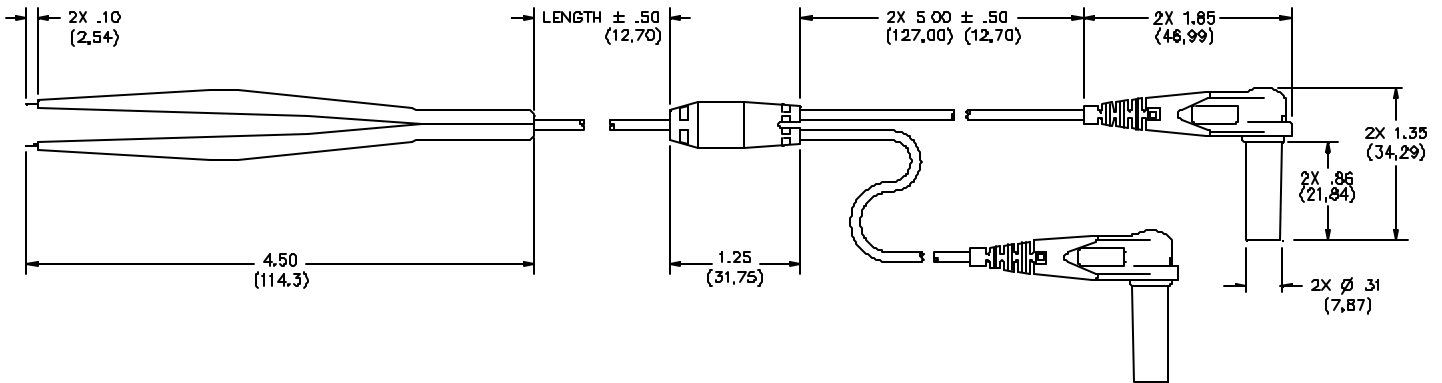

FEATURES:

- Ideal for testing SMD components.
- Two pairs of tweezers may be used as Kelvin leads with 4-wire test instruments.
- Sleeved banana plugs for mating to double insulated banana jacks.

MATERIALS:

Conn: Sleeved Banana Plug

Body: Brass

Spring: Beryllium Copper spring, nickel plated.

Insulation: Flexible PVC.

RATINGS:

Operating Temperature: 122°F. (50°C)

Operating Voltage: 400 VRMS/DC

Current: 3 Amperes Max.

ORDERING INFORMATION: Model 5678

All dimensions are in inches. Tolerances (except noted): .xx = ±.02" (.51 mm), .xxx = ±.005" (.127 mm).
All specifications are to the latest revisions. Specifications are subject to change without notice.
Registered trademarks are the property of their respective companies. Made in USA

TRANSCAT®

▶ Visit us at [Transcat.com!](http://Transcat.com)

35 Vantage Point Drive // Rochester, NY 14624 // Call 1.800.800.5001