

TRANSCAT

▶ Visit us at Transcat.com!

35 Vantage Point Drive Rochester, NY 14624
Call 1.800.800.5001



INSTRUMENTS, LLC

Direct Drive Difference

Member of
FCI
Fluid Controls Institute, Inc.



3D DIRECT DRIVE GAUGE SIX YEAR WARRANTY TO PURCHASER

3D INSTRUMENTS, LLC. warrants to the original purchaser of any 3D INSTRUMENTS, LLC. Direct Drive pressure gauge that it will be free from defects in material and workmanship under normal use and service for a period of six (6) years from the date of delivery to the purchaser. No other express warranty is given and no other affirmation of 3D INSTRUMENTS, LLC., or any of its agents, representatives or dealers, by words or actions, shall constitute a warranty or the assumption by 3D INSTRUMENTS, LLC. of any liability or obligation.

The obligation of 3D INSTRUMENTS, LLC. under this warranty is limited to repairing or replacing as the company may elect any pressure gauge that proves in the company's judgment to be defective in material or workmanship within six (6) years after the date of delivery to the original purchaser. Such defective pressure gauge will be repaired or replaced free of charge to the original purchaser, provided the gauge is returned to 3D INSTRUMENTS, LLC., 15542 CHEMICAL LANE, HUNTINGTON BEACH, CA 92649, with all transportation charges prepaid. 3D INSTRUMENTS, LLC. shall have no obligation or liability extending beyond that of repair or replacement as stated above and without limitation of the foregoing shall have no obligation or liability to the purchaser for any direct or consequential damages or loss of profits. Repaired gauges shall be warranted for the unexpired portion of the original warranty only.

This warranty shall not apply to any product or part which has been subjected to use in excess of applicable 3D INSTRUMENTS, LLC. specification, use in violation of any special conditions noted on the pressure gauge, disassembly, misuse, negligence in handling or extensive testing, nor does it apply to replacement of plugged or damaged bourdon coils resulting from chemical or media contamination.

By acceptance of the 3D INSTRUMENTS, LLC. product the purchaser agrees that (1) the foregoing express warranty of repair and replacement is the exclusive and only warranty to pass with such product or part. (2) The purchaser has not relied on the skill or judgment of 3D INSTRUMENT, LLC. in selecting any such product or part for any particular purpose or need of the purchaser. (3) THE FOREGOING EXPRESS WARRANTY IS IN PLACE AND LIEU OF ALL IMPLIED WARRANTIES, INCLUDING THOSE OF MERCHANTABILITY AND FITNESS FOR A PARTICULAR PURPOSE, and (4) retention or possession of the product or part by the original purchaser or its successors for six (6) years after date of purchase by the original purchaser shall be construed as conclusive evidence that all warranty obligations of 3D INSTRUMENTS, LLC. have been fulfilled and that 3D INSTRUMENTS, LLC. is thereby relieved from all warranty obligations.

DIRECT DRIVE DIFFERENCE

3D Instruments

At 3D Instruments we believe that simple is beautiful. Replacing the antiquated C shape Bourdon tube in our pressure gauges is a unique helically wound Bourdon, The Direct Drive Difference. Our Bourdon coil is coupled directly to the shaft-pointer, the only moving part.

Fewer parts, fewer problems. Regular recalibration is eliminated because there are no complex, wear-prone parts. Linearity is built-in; no span adjustment is necessary- ever And 3D accuracy is maintained throughout the useful life of the gauge, many times longer than those old fashioned designs.

The 3D Direct Drive design gives instant response while resisting pointer pulsation. Overpressure? Even 150% of full scale will not affect the accuracy of most 3D gauges. And, it takes pressures of 500% greater than dial range to result in sensing coil rupture. Even when subject to abuse, 3D Direct Drive gauges last longer

All 3D gauges use the finest materials in construction. We construct our Bourdon tube of Inconel X-750. This is a highly elastic material with excellent corrosion resistance. All other wetted parts are in 316SS. All materials are selected to be compatible with your most challenging applications.



Features

- Helically Wound Bourdon Tube in Inconel X-750
- All Wetted Parts in 316SS or Inconel
- Precision Anti-Friction Sapphire Shaft Bearings
- High Impact Resistant Cyclocac Case
- Needle Edged Pointer
- Human Engineered Dial
- Adjustable Zero Set-Point
- One Moving Part

User Benefits

- No Recalibration Required
- Longer Field Service Life
- Greater Reading Accuracy
- Maintenance Free
- Safer Operation (UL Listed)*
- Corrosion Resistant

-UL Std #SA 6134(N) High Pressure Gas

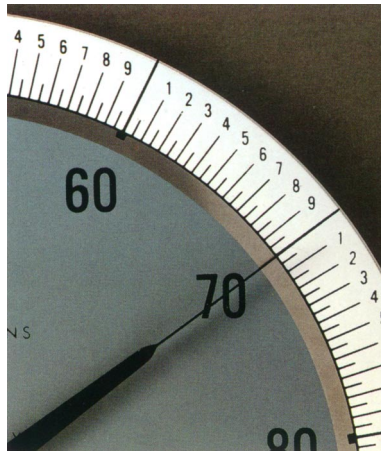

3D Vs. Liquid Filled Gauges

In many severe applications C-shape pressure gauge cases are filled with silicone liquid to dampen their movements and increase service life. Beside adding cost to the gauge, the liquid fill causes other problems. These are associated with loss of liquid fill, discoloration, and added maintenance difficulties. (See ANSI B40.1 3.4.1.5)

3D applies a silicone dampener known as GAD directly to the outer layers of the coil. This GAD dampens the pointer movement in heavy vibration applications eliminating the need for liquid fill. GAD had been proven to perform better than liquid filling in tough applications.

In most instances a standard 3D TLG "Tough Little Gauge" can replace an old fashioned liquid filled gauge. Beside being less expensive, the 3D gauge will provide longer service life and much less field complications for your instrument personnel. Even against liquid fill, 3D gauges can last as much as ten times longer in severe services with pulsation or vibration. This has a dramatic effect on your cost of ownership. After all, 3D gauges are designed to work, and work for a long time no matter what the application.

SIX YEAR Warranty

on the

3D Instruments LLC. warrants to the original purchaser of any 3D Instruments Direct Drive pressure gauge that it will be free from defects in materials and workmanship for a period of six (6) years from the date of delivery to the purchaser. A copy of the full text of the 3D Instruments six year limited warranty is available by pressing here.

The 3D Helical Bourdon Tube

The heart of the 3D Pressure Gauge is the Helically wound Inconel X-750 Bourdon Tube. Inconel was chosen because of its excellent resistance to corrosion and its elasticity. There are two types of helical Bourdon tubes: one is specifically designed for higher pressures and the other is designed for lower pressures. Each pressure range dictates subtle differences in Bourdon tube design and manufacturing method.

To the user the benefits of this painstaking high technology process are longer field life with inherent accuracy and span. As an assembly in the 3D Test or Process gauge our coil provides lower cost of ownership and easier field use, simply because our gauges do not fail or require recalibration. In testing, some 3D Gauges have been cycled over a million times with no appreciable wear or effect on accuracy Some 3D Gauges have been in constant use for more than 15 years, replacing old fashioned gauges which had failed in the same service within weeks.

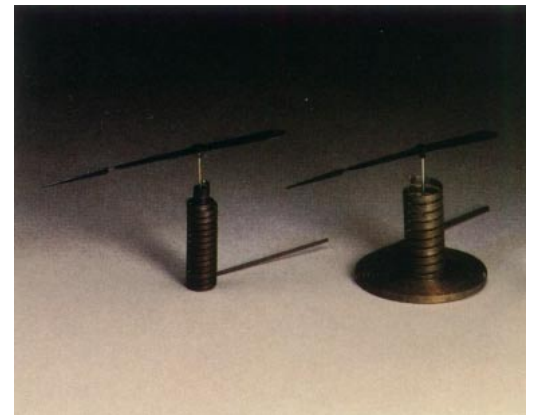

TLG PROCESS GAUGES

Process Gauges

TLG "Tough Little Gauge"

3D Process Gauges are called TLG's for "Tough Little Gauge" Small wonder, our process gauges are designed specifically for the toughest conditions in your process. Typically a 3D TLG can last 4-10 times longer than a standard gauge, even if the standard gauge has been liquid filled. The "Tough Little Gauge" is available in diameters of: 2-1/2", 4-1/2", and 6". The "Dyna-Mount" 4-1/2" TLG is standard with a special swivel fitting and moveable flange. The gauge can be changed to front or back flange and bottom or back mount (except 30 psi) in the field with no more than a screwdriver Standard accuracies are 0.5% mid-scale. Pressure ranges available are from vacuum to 20,000 psi.

The 3D TLG, one "Tough Little Gauge."

Process Dial Graduation Chart (± 0.5% of span @ MidScale, 1% Overall)			
Pressure Range (psia)	Major Floure Interval (psia)	Major Graduatios n (psig)	Minor Graduation (psia)
0 - 30	5	1	0.2
0 - 60	5	1	0.5
0 - 100	10	5	1.0
0 - 150	10	5	1.0
0 - 160	20	10	2.0
0 - 200	20	10	2.0
0 - 300	50	10	2.0
0 - 500	50	10	5.0
0 - 600	50	10	5.0
0 - 1000	100	50	10.0
0 - 1500	100	50	10.0
0 - 2000	200	100	20.0
0 - 3000	500	100	20.0
0 - 4000	500	100	50.0
0 - 5000	1000	500	50.0
0 - 6000	1000	500	50.0
0 - 8000	1000	500	100.0
0 - 10000	1000	500	100.0
0 - 15000	1500	500	100.0
0 - 20000	2000	1000	100.0
30" Hg - 0 Vac	5	5	0.5

Dimensions

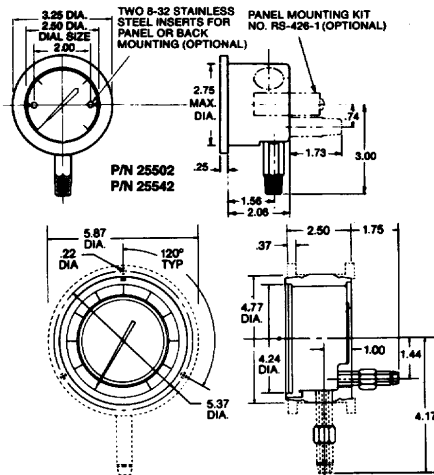

Process & Test Gauge Specifications

Pressure Ranges: 0-30 psig to 0-20,000 psig equivalent ISO and Metric Scales

Compound Ranges: 30" Hg/0-30 psig to 30" Hg/0-300 psig

Receiver Gauges: 3-15 psig or 3-27 psig linear or square root scales

Proof Pressure without calibration shift: 150% of maximum rated pressure

Burst Pressure: 500% of Scale Pressure*

Operating Media: Any media suitable for contact with stainless steel/Inconel.

Calibration: Vertical as standard.

Accuracy:
Process - ± 0.5% of span at mid-range, ± 1.0% overall
Test - + 0.25% or + 0.50% of span. No tapping required ⊕, includes all friction, hysteresis, and linearity variations.

Response Time: Approximately 100ms from 0 to full scale (gas service)

Ambient Temperature: - 65°F to + 190°F (- 54°C to + 88°C)

Service Media Temperature: - 65°F to + 400°F (- 54°C to + 204°C)

Higher temperatures allowable depending on installation.

Life: 250,000 cycles minimum to 1,000,000,* 80% of full scale.

Dial Sizes:
Process - 2-1/2" (64mm) 4-1/2" (114mm) 6" (152mm)
Test - 2-1/2" (64mm) 4-1/2" (114mm) 6" (152mm) 8-1/2" (216mm) 12" (305mm)

Repeatability: ± 0.025% full scale

Sensitivity: ± 0.025% full scale

Materials:
Case - ABS Plastic (std) SS (opt)
Dial, Capillary tube, fittings, screws, and rivets - Stainless Steel ⊕ ⊕
Sensing Element - Inconel X-750

Gauges conform to ANSI B40.1 1991 for "Gauges, Pressure and Vacuum. Dial Type, Elastic Element"

* Except on ultra high pressure (>10,000 psig)
 ** 2-1/2" Dial, Plastic
 ⊕ Except 30 PSI and Caisson Gauges
 ⊕ ⊕ 0.25% Accuracy Gauges are traceable to N.I.S.T. Others available as an option.

Test Gauge Basic Dimensions in Inches (millimeters)												
Model No.	A	B	C	D	E	F	G	H	K	L	M	Panel
255*4	4.83 (122.7)	2.50 (63.5)	6.00 (152.4)	1.00 (25.4)	5.37 (136.4)	1.54 (39.1)	4.99 (126.7)	1.65 (41.9)	0.24 (5.6)	0.50 (12.7)	4.50 (114.3)	5.00 (127.0)
255*5	6.31 (160.3)	2.50 (63.5)	7.63 (193.8)	1.00 (25.4)	7.00 (177.8)	2.13 (54.3)	5.72 (145.3)	1.65 (41.9)	0.28 (7.1)	0.50 (12.7)	6.00 (152.4)	6.50 (165.1)
255*6	8.81 (223.8)	2.50 (63.5)	10.20 (259.1)	1.00 (25.4)	9.63 (244.60)	2.13 (54.3)	6.97 (177.8)	1.65 (41.9)	0.28 (7.1)	0.50 (12.7)	8.50 (215.9)	9.00 (228.8)
255*7	12.50 (317.50)	2.50 (63.5)	14.13 (358.9)	1.00 (25.4)	13.50 (342.9)	2.13 (54.3)	8.82 (224.0)	1.65 (41.9)	0.28 (7.1)	0.50 (12.7)	12.00 (304.8)	12.75 (323.9)

TEST GAUGES

Test Gauges

The 3D Test Gauge series gives you a choice of two different degrees of accuracy to match your application. All 3D accuracy figures are real: they include all friction, error, hysteresis, and linearity variations. And 3D gauges maintain their rated accuracy over the entire life of the gauge. With no gears or wear points there is no need for recalibration.

Every dial is clearly marked for fast, accurate reading with calibrations covering a 270° arc. Parallax is corrected on the test gauges by a neutral glare-free face and a corrosion resistant stainless steel dial, incorporating a polished mirror band. Our test gauges are easy to zero with a front mounted zero adjust screw, virtually the only adjustment necessary over the life of the gauge. 3D test gauges are ideal for field calibrations where rough service conditions cause the need for frequent recalibrations in lesser gauge technologies. 3D Test Gauges are available in; 2-1/2", 4-1/2", 6", 8-1/2", and 12" diameters. Accuracies available are 0.5% and 0.25% of span*. A variety of case configurations and colors is provided so that you can match the exact pressure calibration instrument required for your service.

Test Dial Graduation Chart (± 0.25% and ± 0.5% of span Accuracy)					
Pressure Range (psia)	Major Floure Interval (psia)	Minor Floure Interval (psig)	Major Graduation (psia)	Inter. Graduation (psia)	Minor Graduation (psia)
0 - 30	5	1	5	1	0.1
0 - 60	10	1	10	1	0.2
0 - 100	10	1	10	1	0.5
0 - 150	10	2	10	1	0.5
0 - 200	10	2	10	2	1.0
0 - 300	50	5	50	5	1.0
0 - 500	100	10	100	10	2.0
0 - 600	100	10	100	10	2.0
0 - 1000	100	20	100	10	5.0
0 - 1500	100	20	100	10	5.0
0 - 2000	100	20	100	20	10.0
0 - 3000	500	50	500	50	10.0
0 - 4000	500	100	500	100	20.0
0 - 5000	1000	100	1000	100	20.0
0 - 8000	1000	200	1000	50	50.0
0 - 10000	1000	200	1000	100	50.0
0 - 15000	1000	200	1000	100	50.0
0 - 20000	1000	500	1000	100	100.0
30" Hg - 0 Vac	10	1	10	1	0.2

Dimensions

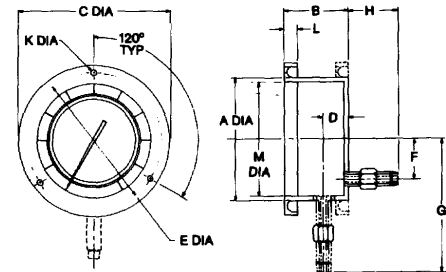

THE INFORMATION CONTAINED HEREIN IS UNCLASSIFIED AND IS THE PROPERTY OF
 STI INDUSTRIES, INC. AND IS LOANED TO YOU HEREBY. IT IS TO BE USED ONLY FOR THE
 PURPOSES AUTHORIZED BY STI INDUSTRIES, INC. AND IS NOT TO BE REPRODUCED OR
 TRANSMITTED IN ANY FORM OR BY ANY MEANS, ELECTRONIC OR MECHANICAL, INCLUDING
 PHOTOCOPYING, RECORDING, OR BY ANY INFORMATION STORAGE AND RETRIEVAL SYSTEM.
 WITHOUT PERMISSION IN WRITING FROM STI INDUSTRIES, INC.

REVISIONS				
NO.	DESCRIPTION	DATE	BY	APP'D.

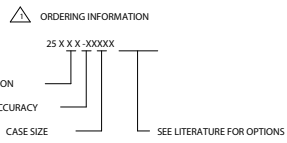
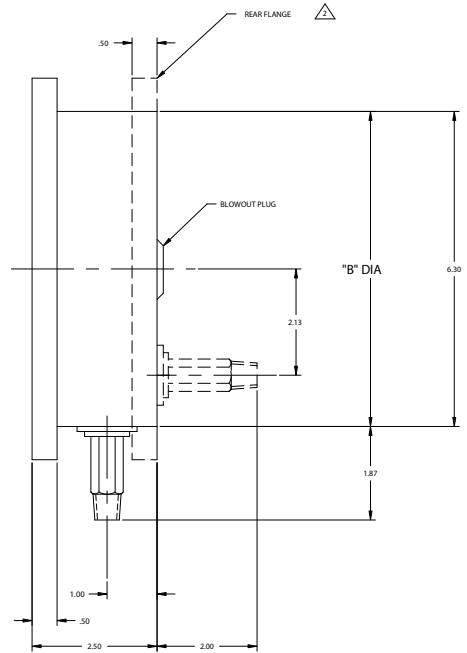
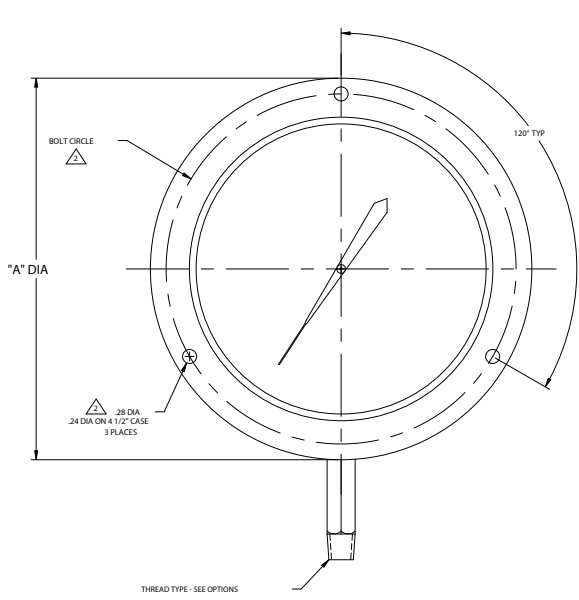

TABULATION TABLE

MODEL	SIZE	"A" DIAMETER	"B" DIAMETER	BOLT CIRCLE	
				FRONT	REAR
25XX4	4 1/2"	6.00"	4.83"	5.37"	5.37" WITH 3 .219 DIA HOLE
25XX5	6"	7.63"	6.31"	7.00"	7.00"
25XX6	8 1/2"	10.20"	8.80"	9.63"	9.63"
25XX7	12"	14.13"	12.50"	13.50"	13.50"

REAR FLANGE ON 4 1/2" GAUGE HAS DIFFERENT MOUNTING HOLE DIAMETER (SEE TABLE).
 THE OUTSIDE DIAMETER IS 5.88" AND THE THICKNESS IS .38".

REFER TO LITERATURE FOR AVAILABLE SCALE RANGES, THREAD TYPE, MOUNTING OPTIONS AND GAUGE SIZES.

NOTES:

UNLESS OTHERWISE SPECIFIED	STI INDUSTRIES, INC.	1000 WEST 10TH AVENUE DENVER, COLORADO 80202
STI INDUSTRIES, INC.	STI INDUSTRIES, INC.	STI INDUSTRIES, INC.
TEST GAUGE OUTLINE DRAWING	D 52159	25XXX-500

REV.	DESCRIPTION	DATE	BY	APPROVED
A	NEW RELEASE	01-14-00	TDM	

PART NUMBER DESCRIPTION
25502-24C11GAD-GCK-GCL-GCO-ISB

CLASSIFICATION: 5 - PRESSURE

ACCURACY: SEE NOTE 1
 SCALE SIZE: 2.5"

SCALE RANGE: -24 (150PSI/10BAR)

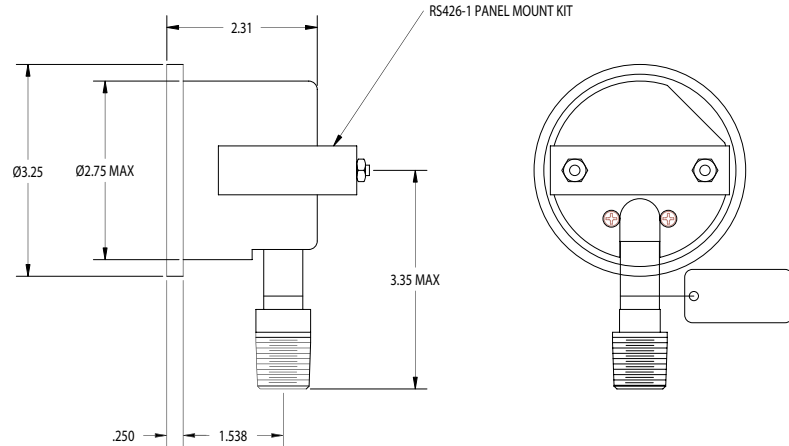
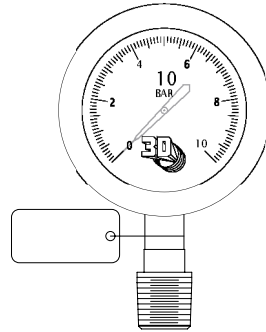
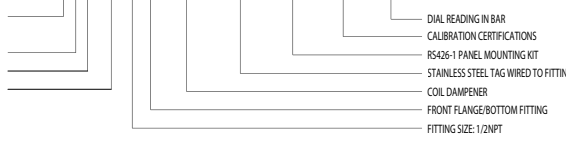

- DIAL - STAINLESS STEEL
- CAPILLARY TUBE - STAINLESS STEEL
- FITTING - STAINLESS STEEL
- SCREWS - STAINLESS STEEL
- SENSING ELEMENT - INCONEL X-750
- CRYSTAL - ACRYLIC
- GASKET - BUNA-N

- MATERIALS: CASE - ABS PLASTIC
- OPERATING MEDIA: ANY MEDIA SUITABLE FOR CONTACT WITH STAINLESS STEEL/INCONEL
- AMBIENT TEMPERATURE RANGE: -65°F TO +190°F. MEDIA TEMPERATURE -65°F TO +400°F.
- CALIBRATION ACCURACY: PRESSURE - ±5% OF SPAN @ MID-SCALE, ±1.0% OVERALL

NOTES: UNLESS OTHERWISE SPECIFIED

UNLESS OTHERWISE SPECIFIED

- DIMENSIONS ARE IN INCHES.
- DWG INTERPRETATIONAL DIMENSIONING AND TOLERANCING PER MIL-STD-100 AND ANSI Y14.6.
- TOLERANCES:
 - DEC = ±0.010
 - XXX = ±.015
 - ANGLES = 1/2°
 - C/HAM = 5°
- DIMENSIONS ARE SHOWN AFTER PLATING.
- SURFACE TOUGHNESS: 40 OR BETTER.
- REMOVE BURRS AND BREAK SHARP EDGES .005 - .015.
- FINISHES: FALLET BASH 210 - DRG.
- THREADS: PER MIL-C-7793.
- GENERAL MFG REQUIREMENTS PER MFG 400.

APPROVALS	
DRAWN	MARPLES
CHECKED	01-14-00
ENGINEERING	
Q.C.	
PRODUCTION	
AUTOCAD FILE NAME	25502-24C11GAD-GCK-GCL-GCO-ISB



TITLE
OUTLINE AND MOUNTING
2.5" BOTTOM 1/2 NPT

SIZE	CAGE CODE NO.	DWG. NO.	REV
B	52159	25502-24C11GAD-GCK-GCL-GCO-ISB	A
SCALE	7:5	SHEET	1 OF 1

THE INFORMATION DISCLOSED HEREIN WAS ORIGINATED BY AND IS THE PROPERTY OF 3-D INSTRUMENTS, INC., AND EXCEPT FOR RIGHTS EXPRESSLY GRANTED TO THE UNITED STATES GOVERNMENT, 3-D INSTRUMENTS, INC. RESERVES ALL PATENT, PHOTO-COPYING, DESIGN, USE, SALE, MANUFACTURING, AND REPRODUCTION RIGHTS THEREOF.

NOTES: UNLESS OTHERWISE SPECIFIED

- CALIBRATION ACCURACY: PROCESS - CODE 0 = ± 5.0% OF SPAN @ MID-SCALE, 1.0% OVERALL
TEST - CODE 4 = ± 25% OF 1.0% OF SPAN.
- CODE 5 = ± 50% OF 1.0% OF SPAN.

- AMBIENT TEMPERATURE RANGE: -65°F TO +190°F. MEDIA TEMPERATURE -65°F TO +400°F.
- OPERATING MEDIA: ANY MEDIA SUITABLE FOR CONTACT WITH 316 SS AND INCONEL X-750.

DIAL - STAINLESS STEEL
CAPILLARY TUBE - STAINLESS STEEL
FITTING - STAINLESS STEEL
SCREWS - STAINLESS STEEL
SENSING ELEMENT - INCONEL X-750
CRYSTAL - ACRYLIC
GASKET - BUNA-N

- MATERIALS: CASE - ABS PLASTIC
- FOR 'VCO' FITTING TYPE, USE B FITTING CODE AND GCDXXI MODE CODE. 'A' AND 'B' DIMENSIONS ARE THE SAME AS THE 'Y' FITTING DIMENSIONS, (5/8 HEX).

[G] 'W' FITTING TYPE IS THE SAME AS 'Y' WITH THE ADDITION OF A TAIL PIECE.

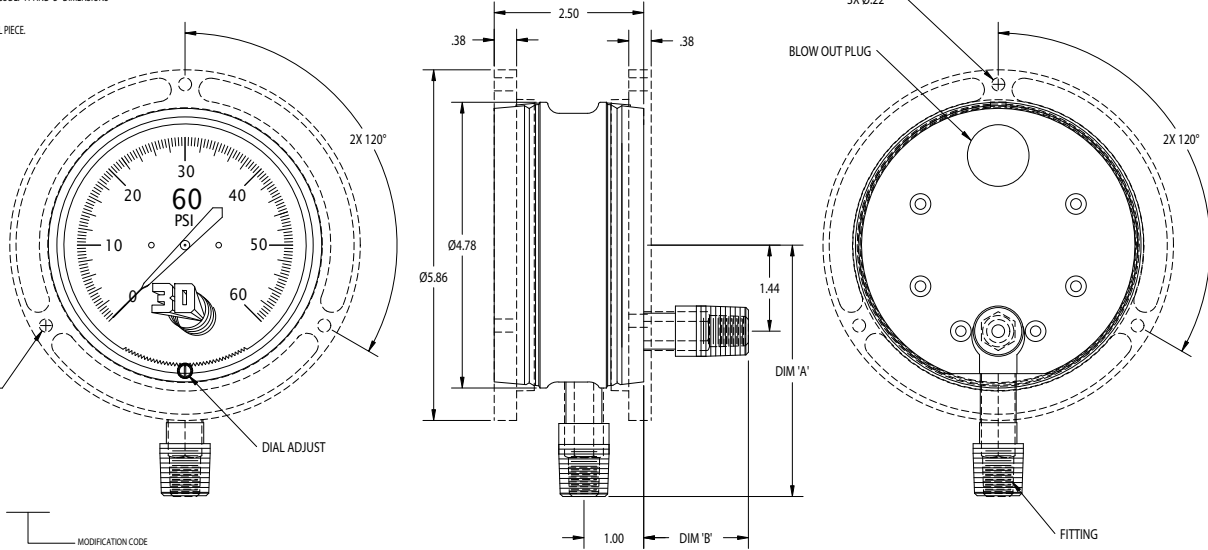

PART NUMBER DESCRIPTION
25XX4-XXXXXXXXXX

CLASSIFICATION: 1 = COMPOUND
2 = VACUUM
5 = PRESSURE
ACCURACY: SEE NOTE 1
SIZE: 4.5 INCH

MODIFICATION CODE

PRESSURE CODES				CONNECTION				ENCLOSURE CONFIGURATION											
CODE NO.	PRESSURE (PSIG)	CODE	DESCRIPTION	HEX OR WRENCH FLAT	DIM 'A'	DIM 'B'	CODE	MOUNTING	FITTING					COLOR					
									FRONT	BACK	NONE	BACK	BOTTOM	BLACK	GREEN	RED	YELLOW		
21	30	A	1/8" NPT MALE	9/16 HEX	3.85	1.40	1X	X					X	1	2	3	4		
22	60	B	1/4" NPT MALE	9/16 HEX	4.17	1.75	2X	X				X	X	1	2	3	4		
23	100	C	1/2" NPT MALE	5/8 FLAT	4.17	1.75	3X	X			X		X	1	2	3	4		
24	150	G	MS33649-4	3/4 HEX	4.34	1.89	4X		X		X		X	1	2	3	4		
25	200	H	MS33656-4	9/16 HEX	4.04	1.59	5X		X		X		X	1	2	3	4		
26	300	MF	MS33514-4	5/8 FLAT	3.03	.58	6X		X	X			X	1	2	3	4		
27	500	W	1/4" NPT MALE	9/16 HEX	4.17	1.75								1	2	3	4		
28	600	Y	ML-1-18997/1	9/16 HEX	3.85	1.40													
29	1000	W	[G]	9/16 HEX	3.85	1.40													
31	1500																		
32	2000																		
33	3000																		
34	4000																		
35	5000																		
36	6000																		
37	8000																		
38	10000																		
39	15000																		
41	20000																		
45	160																		

UNLESS OTHERWISE SPECIFIED
1. DIMENSIONS ARE IN INCHES.
2. DIMENSIONS ARE TO CENTER UNLESS OTHERWISE NOTED.
3. DIMENSIONS FROM BALL END UNLESS OTHERWISE NOTED.
4. TO DIMENSIONS.
5. DRILL TO DIA.
6. DRILL TO DIA.
7. DRILL TO DIA.
8. DRILL TO DIA.
9. DRILL TO DIA.
10. DRILL TO DIA.
11. DRILL TO DIA.
12. DRILL TO DIA.
13. DRILL TO DIA.
14. DRILL TO DIA.
15. DRILL TO DIA.
16. DRILL TO DIA.
17. DRILL TO DIA.
18. DRILL TO DIA.
19. DRILL TO DIA.
20. DRILL TO DIA.
21. DRILL TO DIA.
22. DRILL TO DIA.
23. DRILL TO DIA.
24. DRILL TO DIA.
25. DRILL TO DIA.
26. DRILL TO DIA.
27. DRILL TO DIA.
28. DRILL TO DIA.
29. DRILL TO DIA.
30. DRILL TO DIA.
31. DRILL TO DIA.
32. DRILL TO DIA.
33. DRILL TO DIA.
34. DRILL TO DIA.
35. DRILL TO DIA.
36. DRILL TO DIA.
37. DRILL TO DIA.
38. DRILL TO DIA.
39. DRILL TO DIA.
40. DRILL TO DIA.
41. DRILL TO DIA.
42. DRILL TO DIA.
43. DRILL TO DIA.
44. DRILL TO DIA.
45. DRILL TO DIA.
46. DRILL TO DIA.
47. DRILL TO DIA.
48. DRILL TO DIA.
49. DRILL TO DIA.
50. DRILL TO DIA.
51. DRILL TO DIA.
52. DRILL TO DIA.
53. DRILL TO DIA.
54. DRILL TO DIA.
55. DRILL TO DIA.
56. DRILL TO DIA.
57. DRILL TO DIA.
58. DRILL TO DIA.
59. DRILL TO DIA.
60. DRILL TO DIA.
61. DRILL TO DIA.
62. DRILL TO DIA.
63. DRILL TO DIA.
64. DRILL TO DIA.
65. DRILL TO DIA.
66. DRILL TO DIA.
67. DRILL TO DIA.
68. DRILL TO DIA.
69. DRILL TO DIA.
70. DRILL TO DIA.
71. DRILL TO DIA.
72. DRILL TO DIA.
73. DRILL TO DIA.
74. DRILL TO DIA.
75. DRILL TO DIA.
76. DRILL TO DIA.
77. DRILL TO DIA.
78. DRILL TO DIA.
79. DRILL TO DIA.
80. DRILL TO DIA.
81. DRILL TO DIA.
82. DRILL TO DIA.
83. DRILL TO DIA.
84. DRILL TO DIA.
85. DRILL TO DIA.
86. DRILL TO DIA.
87. DRILL TO DIA.
88. DRILL TO DIA.
89. DRILL TO DIA.
90. DRILL TO DIA.
91. DRILL TO DIA.
92. DRILL TO DIA.
93. DRILL TO DIA.
94. DRILL TO DIA.
95. DRILL TO DIA.
96. DRILL TO DIA.
97. DRILL TO DIA.
98. DRILL TO DIA.
99. DRILL TO DIA.
100. DRILL TO DIA.

APPROVALS	DATE
DRAWN: MARPLES	11-09-00
CHECKED:	
ENGINEERING:	
ELC:	
PRODUCTION:	
AUTOCAD FILE NAME:	25XX4-XXXXX

3D Instruments, Inc.
Direct Drive Difference

10404 CHIMNEY LANE
HARTFORD, CT 06111
TEL: 783-283-1000
FAX: 783-283-1001

STANDARD 4.5 INCH TEST/TLG

SIZE: C 52159
SCALE: FULL
SHEET: 1 OF 1

HOW TO ORDER

How To Order:

To obtain your part number for the type of gauge you need, select one variation under each section heading. Place a check mark immediately below the part number for each variation. When complete, write the part numbers above each check. The resulting number is your part number. (Note: The first two numbers are always 25 as indicated.) Example: 25544-3111313.

Ordering Tables

Test Gauges

Industrial Process Gauges

Options & Accessories

D-M Connector



D-M Snap-On Mounting Flange



Available on 25X04 Series ABS Plastic Case Gauges Only

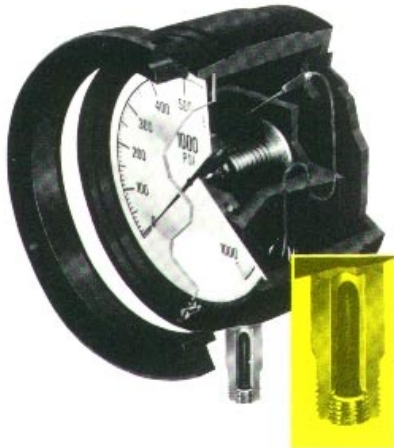

Internal Isolator. The 3D Internal Isolator GP400 prevents the passage of any contaminating product into the bourdon coil system, eliminating plugging. The unit is a sleeve-type elastomer which is threaded into the fitting of 3D gauges after liquid filling of the coil. The GP400 can be operated to full gauge pressure from -40' to + 250'F (- 40'C to + 120' C) without deterioration of gauge accuracy, except on pressure ranges of 100 psi and under The GP400 is not suitable for gas service.

Max Pressure Pointer. A "Dead Hand" pointer is moved by the gauge indicating pointer on increasing pressure, and the "Dead Hand" pointer remains at maximum pressure when the gauge pressure returns to normal or zero. The assembly is mounted on the gauge crystal and has an external reset knob to reposition the pointer. This pointer is available on the 4-1/2, 6, 8-1/2 and 12 inch gauges. (Max pressure pointer may move when used in shock or vibration applications.)

RS380-1 Filter. The RS380-1 Filter is **standard** equipment on all 3D gauges to prevent particles from entering the bourdon coil. Made of 300 series stainless steel for corrosion resistance, RS380-1 is easily removed for cleaning. Filters are available separately.

Custom dial faces. 3D's design and engineering department can provide special dials to customers' specifications upon request. Customized faces may show force or weight, extended ranges, special colors, corporate logo-types, or legends.

ISO and Metric Scale	
Type	Suffix
Kilopascals / Megapascals *	ISO
BAR	ISB
Kg/cm ²	ISK
Note: for dual scale add "D" to suffix. ie; PSI & bar = ISBD. PSI typically on outer arc	

* above 1000 PSI

Process Dial Graduation Chart

(± 0.5% of span @ Midscale, 1% Overall)

Pressure Range (psig)	Major Figure Interval (psig)	Major Graduation (psig)	Minor Graduation (psig)
0 – 30	5	1	0.2
0 – 60	5	1	0.5
0 – 100	10	5	1.0
0 – 150	10	5	1.0
0 – 160	20	10	2.0
0 – 200	20	10	2.0
0 – 300	50	10	2.0
0 – 500	50	10	5.0
0 – 600	50	10	5.0
0 – 1000	100	50	10.0
0 – 1500	100	50	10.0
0 – 2000	200	100	20.0
0 – 3000	500	100	20.0
0 – 4000	500	100	50.0
0 – 5000	1000	500	50.0
0 – 6000	1000	500	50.0
0 – 8000	1000	500	100.0
0 – 10000	1000	500	100.0
0 – 15000	1500	500	100.0
0 – 20000	2000	1000	100.0
30" Hg – 0 Vac	5	5	0.5

Test Dial Graduation Chart

(± 0.25% and ± 0.5% of span Accuracy)

Pressure Range (psig)	Major Figure Interval (psig)	Minor Figure Interval (psig)	Major Graduation (psig)	Inter. Graduation (psig)	Minor Graduation (psig)
0 – 30	5	1	5	1	0.1
0 – 60	10	1	10	1	0.2
0 – 100	10	1	10	1	0.5
0 – 150	10	2	10	1	0.5
0 – 200	10	2	10	2	1.0
0 – 300	50	5	50	5	1.0
0 – 500	100	10	100	10	2.0
0 – 600	100	10	100	10	2.0
0 – 1000	100	20	100	10	5.0
0 – 1500	100	20	100	10	5.0
0 – 2000	100	20	100	20	10.0
0 – 3000	500	50	500	50	10.0
0 – 4000	500	100	500	100	20.0
0 – 5000	1000	100	1000	100	20.0
0 – 8000	1000	200	1000	50	50.0
0 – 10000	1000	200	1000	100	50.0
0 – 15000	1000	200	1000	100	50.0
0 – 20000	1000	500	1000	100	100.0
30" Hg – 0 Vac	10	1	10	1	0.2

MATERIALS OF CONSTRUCTION FOR 3D INSTRUMENTS DIRECT DRIVE PRESSURE GAUGE

Listed below are the component parts of the 3D Direct Drive Pressure Gauge and the materials used in each part:

1. Parts wetted by the measurement media:
 - a. Fitting: 316 stainless steel (SS)
 - b. Connecting capillary: 316 SS
 - c. Joining sleeve: 316 SS
 - d. Sensing coil: Inconel X-750
 - e. Filter: 316 SS

2. Other parts in internal assembly:
 - a. Fitting bracket: 300 series stainless steel
 - b. Pointer shaft: 302 series stainless spring steel
 - c. Shaft bearings: Synthetic sapphire
 - d. Pointer: Aluminum (300 SS on 4½" Process)
 - e. Pointer hub: 316 SS
 - f. Dial support: ABS plastic
 - g. Dial retaining clip: 316 SS
 - h. Mounting plate: ABS plastic (300 SS on 2½")
 - i. Clip: (jointing shaft & coil): 300 series SS
 - j. Dial: 300 SS (ABS plastic on 2½" Process Gauge)

3. Case Parts:
 - a. Case: Cypolac Grade "T" (ABS plastic)
 - b. Zero adjust: 316 SS
 - c. Lens: gasket: Neoprene
 - d. Lens: Acrylic plastic
 - e. Retaining snap ring: 302 SS
 - f. Blowout plug: Neoprene (Mylar on 2½" and SSTL case gauges)
 - g. Fitting mounting screws: 300 series SS
 - h. Plate mounting screws: 300 series SS
 - i. Name plate: Mylar



Series 25

±.50% of span @ midscale, 1% overall accuracy
Process Gauge Ordering Instructions

Part Number Sample: **25** **5** **0** **4** – **23** **B** **7** **4** **XXXX**

Consult Section: **①** **②** **③** **④** **⑤** **⑥** **⑦** **⑧**

① Type of Gauge

P/N Code	Type of Gauge	Comments
1	Compound Vac. & Pressure Gauge	Available from -30" Hg to 0 to 30 PSI up to -30" Hg to 0 to 300 PSI
2	Vacuum Gauge	Only available in -30" Hg to 0 (and equiv. scales). Dial arc is 135°. Use range code 21 in section 4
5	Pressure Gauge	Available in ranges 0 to 30 PSI up to 0 to 20,000 PSI.

② Accuracy of Gauge

(All accuracies are based on total span of the selected bourdon tube range. ie: span of 100 PSI pressure gauge is 100, span of compound -30" Hg to 0 to 100 PSI is 115 PSI)

P/N Code	Accuracy	Comments
0	±.5% of span accuracy @ midscale, 1% overall	Compound ranges are +/- .5% of span accuracy @ midscale, 1% overall on the pressure side. Vacuum side is 1.0% of span from 0 to -20" Hg, 2.0% of span from 21" to 30" Hg. Vacuum
7	2% Receiver Gauge	This Accuracy Used on Receiver Gauges Only

③ Size of Gauge

P/N Code	Accuracy	Comments
2	2.5" Dial Size	Black ABS Case only available Front Flange. Also available in Stainless Steel with or without Flanges
3	3.5" Dial size	Black ABS Case only available Rear Flange. Bolt Circle Diameter on Flange is 4.312"
4	4.5" Dial Size	Black or Yellow ABS Plastic Cases with DynaMount Fitting and Flange or Stainless Steel Case
5	6" Dial Size	Black ABS Plastic Cases, Black or Purple Nylon Cases for Skydrol
6	8.5" Dial Size	Black ABS Plastic Cases
7	12" Dial Size	Black ABS Plastic Cases

④ Pressure Range

P/N Code	Standard Pressure Range	"ISO" Mod Code Use "ISOD" for Dual PSI / Metric	"ISK" Mod Code Use "ISKD" for Dual PSI / Metric	"ISB" Mod code Use "ISBD" for Dual PSI / Metric
-21 Vacuum	-30" Hg to 0 Vacuum	- 100 to 0 kPa	-1 to 0 Kg/cm ² (use "CMP" Mod Code for -760 to 0 mmHg)	-1 to 0 BAR
-21 (Compound)	0 to 30 PSI (-30" Hg to 0 to 15 PSI)	0 to 200 kPa (-100 to 0 to 100 kPa)	0 to 2 Kg/cm ² (-760 mmHg to 0 to 1 Kg/cm ²)	0 to 2 BAR (-1 BAR to 0 to 1 BAR)
-48 Compound Only	-30" Hg to 0 to 30 PSI	-100 to 0 to 200 kPa	-760 mmHg to 0 to 2 Kg/cm ²	-1 to 0 to 2 BAR
-22 (Compound)	0 to 60 PSI (-30" Hg to 0 to 60 PSI)	0 to 400 kPa (-100 to 0 to 400 kPa)	0 to 4 Kg/cm ² (-760 mmHg to 0 to 4 Kg/cm ²)	0 to 4 BAR (-1 to 0 to 4 BAR)
-23 (Compound)	0 to 100 PSI (-30" Hg to 0 to 100 PSI)	0 to 700 kPa (-100 to 0 to 700 kPa)	0 to 7 Kg/cm ² (-760 mmHg to 0 to 7 Kg/cm ²)	0 to 7 BAR (-1 to 0 to 7 BAR)
-24 (Compound)	0 to 150 PSI (-30" Hg to 0 to 150 PSI)	0 to 1000 kPa (-100 to 0 to 1000 kPa)	0 to 10 Kg/cm ² (-760 mmHg to 0 to 10 Kg/cm ²)	0 to 10 BAR (-1 to 0 to 10 BAR)
-46	0 to 160 PSI			
-25 (Compound)	0 to 200 PSI (-30" Hg to 0 to 200 PSI)	0 to 1,400 kPa (-100 to 0 to 1,400 kPa)	0 to 14 Kg/cm ² (-760 mmHg to 0 to 14 Kg/cm ²)	0 to 14 BAR (-1 to 0 to 14 BAR)
-26 (Compound)	0 to 300 PSI (-30" Hg to 0 to 300 PSI)	0 to 2,000 kPa (-100 to 0 to 2,000 kPa)	0 to 21 Kg/cm ² (-760 mmHg to 0 to 21 Kg/cm ²)	0 to 21 BAR (-1 to 0 to 21 BAR)
-27	0 to 500 PSI	0 to 3,500 kPa	0 to 35 Kg/cm ²	0 to 35 BAR
-28	0 to 600 PSI	0 to 4,000 kPa	0 to 42 Kg/cm ²	0 to 42 BAR
-29	0 to 1,000 PSI	0 to 7,000 kPa	0 to 70 Kg/cm ²	0 to 70 BAR
-31	0 to 1,500 PSI	0 to 10 MPa	0 to 100 Kg/cm ²	0 to 100 BAR
-32	0 to 2,000 PSI	0 to 14 MPa	0 to 140 Kg/cm ²	0 to 140 BAR
-33	0 to 3,000 PSI	0 to 20 MPa	0 to 210 Kg/cm ²	0 to 210 BAR

Pressure Range Continued on Next Page

④ Pressure Range (Continued)

P/N Code	Standard Pressure Range	"ISO" Mod Code Use "ISOD" for Dual PSI / Metric	"ISK" Mod Code Use "ISKD" for Dual PSI / Metric	"ISB" Mod code Use "ISBD" for Dual PSI / Metric
-34	0 to 4,000 PSI	0 to 28 MPa	0 to 280 Kg/cm ²	0 to 280 BAR
-35	0 to 5,000 PSI	0 to 35 MPa	0 to 350 Kg/cm ²	0 to 350 BAR
-36	0 to 6,000 PSI	0 to 40 MPa	0 to 420 Kg/cm ²	0 to 420 BAR
-37	0 to 8,000 PSI #	0 to 56 MPa #	0 to 560 Kg/cm ² #	0 to 560 BAR #
-38	0 to 10,000 PSI #	0 to 70 MPa #	0 to 700 Kg/cm ² #	0 to 700 BAR #
-39	0 to 15,000 PSI ##	0 to 100 MPa ##	0 to 1,000 Kg/cm ² ##	0 to 1,000 BAR ##
-41	0 to 20,000 PSI ##	0 to 140 MPa ##	0 to 1,400 Kg/cm ² ##	0 to 1,400 BAR ##

= High Pressure – Pressure Accuracy 0.25% of Span Upscale, 0.50% of Span Downscale for 2554 Series Only.
 ## = Ultra High Pressure – Pressure Accuracy 1.0% of Span Upscale, 2.0% of Span Downscale.

See Accuracy Section ② for Detailed Accuracy on Vacuum and Compound Ranges.

⑤ Fitting Size

P/N Code	Fitting Size	Comments
B	1/4" NPT Male Thread	
C	1/2" NPT Male Thread	<i>Not available on 2.5" Dial Size with Stainless Steel Case. Not recommended for ranges above 6000 PSI.</i>

⑥ Case Style

P/N Code	Flange / Fitting Location	Comments
1	Front Flange / Bottom Fitting	<i>For 2.5" ABS Case, Order P/N RS426-1 for Panel Mounting</i>
2	Front Flange / Lower Back Fitting	<i>For 2.5" ABS Case, Order P/N RS426-1 for Panel Mounting</i>
3	Back Flange / Bottom Fitting	<i>Not Available on 2.5" ABS</i>
4	Back Flange / Lower Back Fitting	<i>Not Available on 2.5" ABS</i>
5	No Flange / Bottom Fitting	<i>Not Available on 2.5" ABS</i>
6	No Flange / Lower Back Fitting	<i>Not Available on 2.5" ABS</i>
7	Detached Flange / Bottom Fitting	<i>Only Available on 4.5" Black or Yellow ABS</i>
8	Detached Flange / Lower Back Fitting	<i>Only Available on 4.5" Black or Yellow ABS</i>

⑦ Case Color

P/N Code	Case Color and Material	Comments
1	Black ABS Plastic	
4	Yellow ABS Plastic	<i>Only Available on 4.5" Dial Size</i>
5	Electro-Polished Stainless Steel	<i>Only Available on 2.5" and 4.5" Dial Sizes</i>
7	Purple Nylon	<i>Only Available on 6" Dial Sizes</i>

⑧ Options (Consult Factory for Additional Options)

P/N Code	Description of Option	Comments
ISO	Metric Scale in kPa or MPa	<i>See Pressure Range Section for Available Scales</i>
ISOD	Dual Scale PSI and kPa or MPa	<i>See Pressure Range Section for Available Scales</i>
ISK	Metric Scale in Kg/cm ²	<i>See Pressure Range Section for Available Scales</i>
ISKD	Dual Scale PSI and Kg/cm ²	<i>See Pressure Range Section for Available Scales</i>
ISB	Metric Scale in BAR	<i>See Pressure Range Section for Available Scales</i>
ISBD	Dual Scale PSI and BAR	<i>See Pressure Range Section for Available Scales</i>
GAD	Silicone Bourdon Tube Dampener	<i>Replaces Liquid Filled Cases</i>
GAB	Gauge Suitable for Skydrol Use	<i>Must be ordered with Nylon or Stainless Steel Case</i>
GCL	RS426-1 Panel Mounting Kit for 2.5" ABS	<i>Required for Panel mounting 2.5" ABS Plastic Cases</i>
GCK	Stainless Steel Tag Wired to Gauge Fitting	
GBH	Liquid O2 Clean per 3D Spec. RYY02-014	
GBK	Gaseous O2 Clean per 3D Spec. RYY110-102	
GBT	Laminated Glass Crystal for 4.5" Stainless Steel Case	



Series 25

0.25% and 0.50% of Span Accuracy

Test Gauge Ordering Instructions

Part Number Sample: **25** **5** **4** **4** - **23** **B** **1** **1** **XXXX**

Consult Section: **①** **②** **③** **④** **⑤** **⑥** **⑦** **⑧**

① Type of Gauge

P/N Code	Type of Gauge	Comments
1	Compound Vac. & Pressure Gauge	Available from -30" Hg to 0 to 30 PSI up to -30" Hg to 0 to 300 PSI
2	Vacuum Gauge	Only available in -30" Hg to 0 (and equiv. scales). Dial arc is 135°. Use range code 21 in section 4
5	Pressure Gauge	Available in ranges 0 to 30 PSI up to 0 to 20,000 PSI.
6	Caisson Gauge	Consult Caisson Ordering Instructions

② Accuracy of Gauge

(All accuracies are based on total span of the selected bourdon tube range. ie: span of 100 PSI pressure gauge is 100, span of compound -30" Hg to 0 to 100 PSI is 115 PSI)

P/N Code	Accuracy	Comments
4	0.25% of span	Compound ranges are 0.25% of span accuracy on the pressure side. Vacuum side is 0.5% of span from 0 to -20" Hg, 1.0% of span from 21" to 30" Hg. Vacuum, 15,000 PSI and 20,000 PSI are not available with 0.25%
5	0.50% of span	15,000 PSI range is 0.50% of span upscale accuracy, 1.0% of span downscale. 20,000 PSI range is 1.0% of span upscale accuracy, 2.0% of span downscale.

③ Size of Gauge

P/N Code	Accuracy	Comments
2	2.5" Dial Size	Black ABS Case only available Front Flange. Also available in Stainless Steel with or without Flanges
4	4.5" Dial Size	Black, Yellow, Red or Green ABS Plastic Cases, Black Nylon for Skydrol or Stainless Steel Case
5	6" Dial Size	Black, Yellow, Red or Green ABS Plastic Cases, Black or Purple Nylon Cases for Skydrol
6	8.5" Dial Size	Black, Yellow, Red or Green ABS Plastic Cases
7	12" Dial Size	Black, Yellow, Red or Green ABS Plastic Cases

④ Pressure Range

P/N Code	Standard Pressure Range	"ISO" Mod Code Use "ISOD" for Dual PSI / Metric	"ISK" Mod Code Use "ISKD" for Dual PSI / Metric	"ISB" Mod code Use "ISBD" for Dual PSI / Metric
-21 Vacuum	-30" Hg to 0 Vacuum	- 100 to 0 kPa	-1 to 0 Kg/cm ² (use "CMP" Mod Code for -760 to 0 mmHg)	-1 to 0 BAR
-21 (Compound)	0 to 30 PSI (-30" Hg to 0 to 15 PSI)	0 to 200 kPa (-100 to 0 to 100 kPa)	0 to 2 Kg/cm ² (-760 mmHg to 0 to 1 Kg/cm ²)	0 to 2 BAR (-1 BAR to 0 to 1 BAR)
-48 Compound Only	-30" Hg to 0 to 30 PSI	-100 to 0 to 200 kPa	-760 mmHg to 0 to 2 Kg/cm ²	-1 to 0 to 2 BAR
-22 (Compound)	0 to 60 PSI (-30" Hg to 0 to 60 PSI)	0 to 400 kPa (-100 to 0 to 400 kPa)	0 to 4 Kg/cm ² (-760 mmHg to 0 to 4 Kg/cm ²)	0 to 4 BAR (-1 to 0 to 4 BAR)
-23 (Compound)	0 to 100 PSI (-30" Hg to 0 to 100 PSI)	0 to 700 kPa (-100 to 0 to 700 kPa)	0 to 7 Kg/cm ² (-760 mmHg to 0 to 7 Kg/cm ²)	0 to 7 BAR (-1 to 0 to 7 BAR)
-24 (Compound)	0 to 150 PSI (-30" Hg to 0 to 150 PSI)	0 to 1000 kPa (-100 to 0 to 1000 kPa)	0 to 10 Kg/cm ² (-760 mmHg to 0 to 10 Kg/cm ²)	0 to 10 BAR (-1 to 0 to 10 BAR)
-46	0 to 160 PSI			
-25 (Compound)	0 to 200 PSI (-30" Hg to 0 to 200 PSI)	0 to 1,400 kPa (-100 to 0 to 1,400 kPa)	0 to 14 Kg/cm ² (-760 mmHg to 0 to 14 Kg/cm ²)	0 to 14 BAR (-1 to 0 to 14 BAR)
-26 (Compound)	0 to 300 PSI (-30" Hg to 0 to 300 PSI)	0 to 2,000 kPa (-100 to 0 to 2,000 kPa)	0 to 21 Kg/cm ² (-760 mmHg to 0 to 21 Kg/cm ²)	0 to 21 BAR (-1 to 0 to 21 BAR)
-27	0 to 500 PSI	0 to 3,500 kPa	0 to 35 Kg/cm ²	0 to 35 BAR
-28	0 to 600 PSI	0 to 4,000 kPa	0 to 42 Kg/cm ²	0 to 42 BAR
-29	0 to 1,000 PSI	0 to 7,000 kPa	0 to 70 Kg/cm ²	0 to 70 BAR
-31	0 to 1,500 PSI	0 to 10 MPa	0 to 100 Kg/cm ²	0 to 100 BAR
-32	0 to 2,000 PSI	0 to 14 MPa	0 to 140 Kg/cm ²	0 to 140 BAR
-33	0 to 3,000 PSI	0 to 20 MPa	0 to 210 Kg/cm ²	0 to 210 BAR

Pressure Range Continued on Next Page

④ Pressure Range (Continued)

P/N Code	Standard Pressure Range	"ISO" Mod Code Use "ISOD" for Dual PSI / Metric	"ISK" Mod Code Use "ISKD" for Dual PSI / Metric	"ISB" Mod code Use "ISBD" for Dual PSI / Metric
-34	0 to 4,000 PSI	0 to 28 MPa	0 to 280 Kg/cm ²	0 to 280 BAR
-35	0 to 5,000 PSI	0 to 35 MPa	0 to 350 Kg/cm ²	0 to 350 BAR
-36	0 to 6,000 PSI	0 to 40 MPa	0 to 420 Kg/cm ²	0 to 420 BAR
-37	0 to 8,000 PSI #	0 to 56 MPa #	0 to 560 Kg/cm ² #	0 to 560 BAR #
-38	0 to 10,000 PSI #	0 to 70 MPa #	0 to 700 Kg/cm ² #	0 to 700 BAR #
-39	0 to 15,000 PSI ##	0 to 100 MPa ##	0 to 1,000 Kg/cm ² ##	0 to 1,000 BAR ##
-41	0 to 20,000 PSI ##	0 to 140 MPa ##	0 to 1,400 Kg/cm ² ##	0 to 1,400 BAR ##

= High Pressure – Pressure Accuracy 0.25% of Span Upscale, 0.50% of Span Downscale for 2554 Series Only.
 ## = Ultra High Pressure – 15,000 PSI Pressure Accuracy 0.50% of Span Upscale, 1.0% of Span Downscale. Available on 2555 Series Only.
 20,000 PSI Pressure Accuracy 1.0% of Span Upscale, 2.0% of Span Downscale. Available on 2555 Series Only.

See Accuracy Section ② for Detailed Accuracy on Vacuum and Compound Ranges.

⑤ Fitting Size

TRANSCAT

Visit us at Transcat.com!
 35 Vantage Point Drive // Rochester, NY 14624 // Call 1.800.800.5001

P/N Code	Fitting Size	Comments
B	1/4" NPT Male Thread	
C	1/2" NPT Male Thread	Not available on 2.5" Dial Size with Stainless Steel Case. Not recommended for ranges above 6000 PSI.

⑥ Case Style

P/N Code	Flange / Fitting Location	Comments
1	Front Flange / Bottom Fitting	For 2.5" ABS Case, Order P/N RS426-1 for Panel Mounting
2	Front Flange / Lower Back Fitting	For 2.5" ABS Case, Order P/N RS426-1 for Panel Mounting
3	Back Flange / Bottom Fitting	Not Available on 2.5" ABS
4	Back Flange / Lower Back Fitting	Not Available on 2.5" ABS
5	No Flange / Bottom Fitting	Not Available on 2.5" ABS
6	No Flange / Lower Back Fitting	Not Available on 2.5" ABS
7	Not Available on Test Gauges	
8	Not Available on Test Gauges	

⑦ Case Color

P/N Code	Case Color and Material	Comments
1	Black ABS Plastic	
2	Green ABS Plastic	Not Available on 2.5" Dial Size
3	Red ABS Plastic	Not Available on 2.5" Dial Size
4	Yellow ABS Plastic	Not Available on 2.5" Dial Size
5	Electro-Polished Stainless Steel	Only Available on 2.5" and 4.5" Dial Sizes
7	Purple Nylon	Only Available on 6" Dial Sizes
8	Black Nylon	Only Available on 4.5" and 6" Dial Sizes

⑧ Options (Consult Factory for Additional Options)

P/N Code	Description of Option	Comments
ISO	Metric Scale in kPa or MPa	See Pressure Range Section for Available Scales
ISOD	Dual Scale PSI and kPa or MPa	See Pressure Range Section for Available Scales
ISK	Metric Scale in Kg/cm ²	See Pressure Range Section for Available Scales
ISKD	Dual Scale PSI and Kg/cm ²	See Pressure Range Section for Available Scales
ISB	Metric Scale in BAR	See Pressure Range Section for Available Scales
ISBD	Dual Scale PSI and BAR	See Pressure Range Section for Available Scales
GAD	Silicone Bourdon Tube Dampener	Replaces Liquid Filled Cases May Effect Accuracy on Low Pressure Ranges
GAB	Gauge Suitable for Skydrol Use	Must be ordered with Nylon or Stainless Steel Case
GCL	RS426-1 Panel Mounting Kit for 2.5" ABS	Required for Panel mounting 2.5" ABS Plastic Cases
GCK	Stainless Steel Tag Wired to Gauge Fitting	
GBH	Liquid O2 Clean per 3D Spec. RYY02-014	
GBK	Gaseous O2 Clean per 3D Spec. RYY110-102	
GBT	Laminated Glass Crystal for 4.5" Stainless Steel Case	