

Rosemount 0085 Pipe Clamp Sensor

- *Non-intrusive design for fast and easy temperature measurement in piping applications*
- *Platinum RTD Temperature Sensors with silver or nickel tip*
- *Non intrusive design for measurement on pipe applications*
- *Temperature-sensor matching provides increased measurement accuracy*
- *Wide range of calibration options provide maximum measurement reliability*
- *Integrated temperature assemblies provide time and cost savings*
- *Integral assembly with 248 or 648 wireless temperature transmitter provides unparalleled mounting flexibility and accuracy for field-mounted pipeline temperature measurements*



Content

Rosemount 0085 Pipe Clamp Sensor	page 2
Overview	page 3
Product Certifications	page 6
Pipe Clamp Assembly with Integrated Connection Head or Head Mounted Transmitter	page 7
Pipe Clamp Sensor Assembly with Cable	page 11
Accessories	page 13

Rosemount Pipe Clamp Sensor

Rosemount 0085 Pipe Clamp Sensor

Proven Pipe Clamp sensors deliver excellent performance and reliability

- Superior accuracy and stability
- Decreased response time with silver and nickel tip
- Calibrations according DKD standards

Easy implementation and installation in existing application

- Available in a wide variety of pipe sizes and material
- Installation with only two screws – no welding needed
- Optimized surface contact by spring loaded sensor design



Minimized risk of sensor failure and unplanned shutdowns

- Avoids flow, pressure, chemical, abrasion, vibration and bending stresses, and thus measuring errors
- Maintenance of sensor without shutdown of process

Achieve optimal efficiency with Rosemount wireless transmitter offering

- Measure your temperature where you need it - at well heads, on offshore platforms, or even pipelines

Explore the benefits of a Complete Point Solution from Rosemount Temperature Measurement

- An “Assemble Sensor” option enables Emerson to provide a complete point temperature solution, delivering an installation-ready transmitter and sensor assembly
- Emerson has a complete portfolio of Single Point, High Density, and Wireless Temperature Measurement solutions, allowing you to effectively measure and control your processes with the reliability you trust from Rosemount products



Experience global consistency and local support from numerous worldwide Rosemount Temperature sites



- Experienced Instrumentation Consultants help select the right product for any temperature application and advise on best installation practices.
- An extensive global network of Emerson service and support personnel can be on-site when and where they are needed.

Overview

Rosemount Pipe Clamp Overview

Emerson offers a wide range of RTDs and thermocouples alone, or as integrated temperature assemblies including Rosemount Temperature Transmitters and connection heads.

Rosemount Pipe Clamp Platinum RTD Sensors are highly linear and have a stable resistance versus temperature relationship. They are used primarily in industrial environments where high accuracy, durability, and long-term stability are required, and are designed to meet the most critical parameters of international standards: IEC 751 1983/DIN EN 60751 incorporating Amendments 1 and 2.⁽¹⁾

RTD sensors offer enhanced performance and optimal pipe clamp temperature measurement accuracy when coupled with temperature transmitters using Callendar-van Dusen constants. Emerson offers two designs of the Pipe Clamp RTD Sensor. The grated head design is suitable for all above ground applications such as refineries, chemical plants, and oil and gas fields. The Pipe Clamp RTD Design with Cable meets the requirements for underground installation and allows for long wiring distances and for pipe movement in extreme environments.

Rosemount Pipe Clamp Sensors are available with flying lead or terminal block lead wire terminations in a variety of lengths and ranges and are available in single and dual element types. Additionally, spring loaded pipe clamps are offered for most industrial applications in a wide range of materials, styles, and lengths. Standard materials include SST 304 and Duplex, while other materials for corrosive environments are also available. Emerson also offers Pipe Clamp Sensors as cable assemblies. Consult with your Emerson representative for more information.

Selecting the Extension Length for a Pipe Clamp Sensor

A direct mounting configuration allows heat from the process, aside from ambient temperature variations, to transfer from the pipe clamp to the transmitter housing. If the expected process surface temperature is near or above the transmitter specification limits, consider using additional extension length or a remote mounting configuration to isolate the transmitter. Figure 1 provides an example of the relationship between transmitter housing temperature rise and distance from the process.

FIGURE 1. Transmitter Housing Temperature Rise vs. Uninsulated Distance from the Process

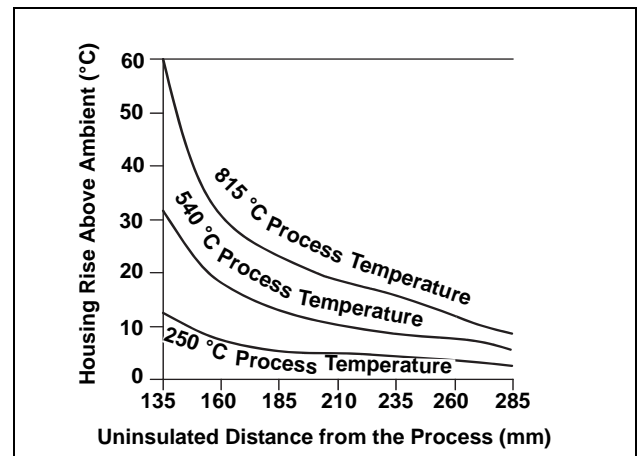

Example

The rated ambient temperature specification for the transmitter is 85 °C. If the maximum ambient temperature is 40 °C and the temperature to be measured is 540 °C, the maximum allowable housing temperature rise is the rated temperature specification limit minus the existing ambient temperature (85 – 40), or 45 °C.

As shown in Figure 1, an uninsulated distance from the process of 90 mm will result in a housing temperature rise of 22 °C. Therefore, 100 mm would be the minimum recommended distance from the process providing a safety factor of about 25 °C. A longer length, such as 150 mm, is desired to reduce errors caused by transmitter temperature effect, although in that case the transmitter may require extra support.

(1) 100 Ω at 0 °C, α = 0.00385 Ω x °C/Ω

Rosemount Pipe Clamp Sensor

TRANSMITTER-SENSOR MATCHING

By using a temperature sensor matched to a temperature transmitter, significant measurement accuracy improvement can be attained. This involves identifying the relationship between resistance and temperature for a specific RTD sensor. This relationship is approximated by the Callendar-van Dusen equation:

$$R_t = R_0 + R_0\alpha[t - \delta(0.01t - 1)(0.01t) - \beta(0.01t - 1)(0.01t)^3],$$

where:

R_t = Resistance (ohms) at Temperature t (°C)

R_0 = Sensor-Specific Constant (Resistance at $t = 0$ °C)

α = Sensor-Specific Constant

δ = Sensor-Specific Constant

β = Sensor-Specific Constant (0 at $t > 0$ °C)

The exact values for the Callendar-van Dusen constants (R_0 , α , δ , β) are specific to each RTD sensor and are established by testing each individual sensor at various temperatures. Rosemount Pipe Clamp RTD Sensors can be ordered Sensor Calibrated to a Fixed Temperature Range, as shown in Table 2 on page 5, where the values of all four sensor specific constants are supplied for each sensor. To utilize the unique, built-in sensor-matching capability of the Rosemount 644 and 3144P transmitters, the Callendar-van Dusen constants can be programmed into the transmitter at the factory, or in the field using a Field Communicator.

The transmitter uses the Callendar-van Dusen constants to generate a sensor curve describing the relationship between resistance and temperature for this particular sensor and transmitter assembly. There is a 3- or 4-fold improvement in temperature measurement accuracy for the total system by using the sensor's actual resistance vs. temperature curve.

The sensor is calibrated specific to a particular temperature range and, as with calibration schedules, the accuracies associated with this option represent worst case conditions, when the sensor is used over the entire temperature range.

IEC 751 Interpretation

The Callendar-van Dusen equation is one method used to describe the resistance versus temperature (R vs.T) relationship for platinum RTDs. International Standard IEC 751 interprets the R vs. T relationship using an approach similar to the Callendar-van Dusen methodology. The IEC 751 R vs.T relationship standard uses the following equation:

$$R_t = R_0[1 + At + Bt^2 + C(t-100)t^3]$$

As in the Callendar-van Dusen method, R_0 , A, B, C are specific for each RTD and are established by testing each sensor at various temperatures. The actual values for A, B, and C differ in magnitude from the Callendar-van Dusen constants (R_0 , α , β , δ), while R_0 is the same for both equations. Either methodology produces the same result in any Transmitter-Sensor Matching scenario, since one equation is a simple mathematical interpretation of the other.

TABLE 1. Pipe Clamp Interchangeability

Pipe Clamp RTD IEC-751 Class B	Temperature
±0.80 °C (±1.44 °F)	-100 °C (-148 °F)
±0.30 °C (±0.54 °F)	0 °C (32 °F)
±0.80 °C (±1.44 °F)	100 °C (-212 °F)
±1.80 °C (±3.24 °F)	300 °C (572 °F)
±2.30 °C (±4.14 °F)	400 °C (752 °F)
Pipe Clamp RTD with IEC-751 Class A Option	Temperature
±0.35 °C (±0.63 °F)	-100 °C (-148 °F)
±0.15 °C (±0.27 °F)	-0 °C (32 °F)
±0.35 °C (±0.63 °F)	100 °C (212 °F)
±0.75 °C (±1.35 °F)	300 °C (572 °F)
±0.95 °C (±1.71 °F)	400 °C (752 °F)

Typical Transmitter-Sensor Matching Accuracy Improvements

Transmitter: Rosemount 3144P (built-in sensor matching capabilities), span of 0 to 200 °C, accuracy = 0.1 °C)

Sensor: Pipe Clamp RTD

Callendar-van Dusen Option: -50 to 150 °C

Process Temperature: 150 °C

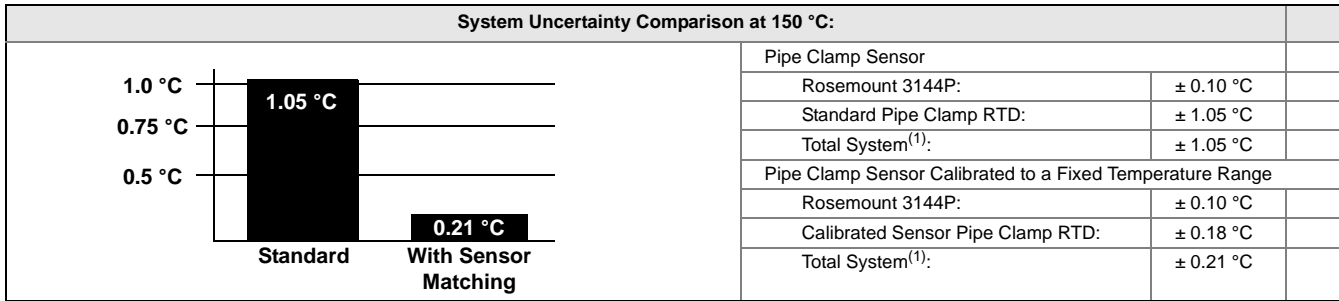

(1) Calculated using RSS statistical method:

$$\text{System accuracy} = \sqrt{(\text{Transmitter accuracy})^2 + (\text{Sensor accuracy})^2}$$

CALIBRATION

Sensor calibration may be needed for input to quality systems, or for control system enhancement. It is used mainly to improve the overall temperature measurement performance by matching the sensor to a temperature transmitter.

Calibration Options

Sensor Calibrated to a Customer-Specified Temperature Range option calibrates the sensor to a customer-specified temperature range. The Callendar-van Dusen, and A, B, and C-constants are supplied with a calibration certificate.

NOTE

When ordering an RTD with this option, the temperature range for the sensor calibration needs to be specified.

Sensor Calibrated to a Customer-Specified Single Measurement Point option refers to the above option when calibrated on a single temperature point.

Sensor Calibrated to a Fixed Temperature Range option is where the RTD sensor is calibrated within standard temperature ranges (Table 2 on page 5). To achieve optimum performance, select the option that corresponds to the operating temperature range for your application.

TABLE 2. Temperature Range Options

Temperature Range	Calibration Points (°C)
0 to 100 °C (32 to 212 °F)	0, 50, 100
-50 to 100 °C (-58 to 212 °F)	-50, 0, 50, 100
-50 to 150 °C (-58 to 302 °F)	-50, 0, 100, 150

SENSOR TIP MATERIAL CONFIGURATION

The mount Pipe Clamp Sensor plate tip is constructed of silver or nickel for better thermal conductivity and to reduce the thermal response time of stainless steel designs. Silver tip plate temperature range is -50 to 300 °C (-58 to 572 °F), and the nickel tip plate temperature range is -110 to 300 °C (-166 to 572 °F).

Rosemount Pipe Clamp Sensor

Product Certifications

HAZARDOUS LOCATIONS CERTIFICATION

Flameproof Approval

Marking  II 2 G

Certification Number. KEMA99ATEX8715

Ex d IIC T6 ($-40 \leq T_{amb} \leq 70$ °C)

The Flameproof approval is dependent on the Rosemount Connection Head assembled with a Rosemount RTD or thermocouple temperature sensor (see Figure 2). The captive flame arrester insert must be fully engaged into the connection head for compliance with this approval.

Flameproof Approval

Marking  II 2 G

Certification Number. KEMA01ATEX2181.

Ex d IIC T5 ($-40 \leq T_{amb} \leq 80$ °C)

Ex d IIC T6 ($-40 \leq T_{amb} \leq 70$ °C)

The Rosemount Pipe Clamp RTD Temperature Sensor with 1/2-in. ANPT Spring Loaded Adapters are approved for direct mount to the Rosemount 3144P Temperature Transmitter (Reference Manual 00809-0100-4021) or the Rosemount 648 Wireless Temperature Transmitter (Reference Manual 00809-0100-4648). For installation information, see the Reference Manuals cited above.

FIGURE 2. Flameproof Configuration.

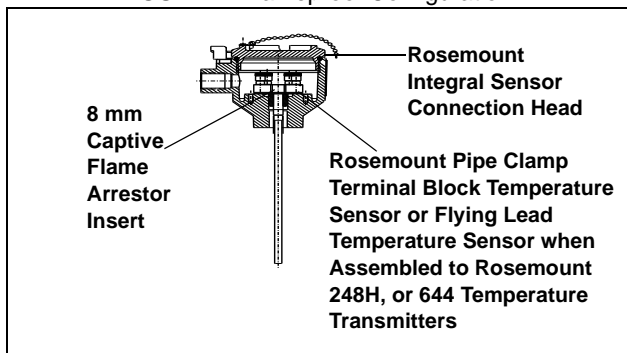

Intrinsic Safety Approval

ATEX Marking  II 2 G

Certificate Number IBExU03ATEX1066X

Ex ia IIC T6 ($-51 \leq T_{amb} \leq 60$ °C)

The Intrinsic Safety Approval is valid for Rosemount Pipe Clamp RTD Sensors, and can only be applied in Zone 1.

The marking of intrinsically safe circuits is by color codes, or print. A mounted on connection head is provided with a grounding screw and a blue cable gland.

Pipe Clamp Assembly with Integrated Connection Head or Head Mounted Transmitter Specifications

Rosemount Pipe Clamp Platinum RTD

Nominal Resistance

In accordance with DIN EN 60751, the nominal resistance is defined:

100 Ω RTD at 0 °C

$\alpha = 0.00385 \text{ } \Omega \times \text{ } ^\circ\text{C}/\Omega$, averaged between 0 and 100 °C

Limit Deviations

Tolerance Class B, as standard $t = \pm(0.3 + 0.005 \times [t])$; temperature range -110 to 300 °C

Tolerance Class A, as option $t = (0.15 + 0.002 \times [t])$; temperature range 0 to 250 °C

Process Temperature Range

-110 to 300 °C (-166 to 572 °F)

Ambient Temperature Range

-51 to 85 °C (-60 to 185 °F)

Self-Heating

0.15 K/mW when measured as defined in DIN EN 60751; 1996.

Insulation Resistance (RTD)

1,000 MΩ minimum insulation resistance when measured at 500 V dc at room temperature

Sheath Material

321 SST with mineral insulated cable construction and silver or nickel plate tip

Lead Wires

PTFE insulated, silver-coated copper wire (Figure 3)

Identification Data

The model and serial numbers are marked on the bottom of the sensor DIN mounting plate or engraved directly on the spring loaded adapter

Ingress Protection (IP) Rating for connection head

IP65 and NEMA 4X.

Hazardous Locations Certifications

According to Ex ia

Ex d

FIGURE 3. Sensor Lead Wire Termination

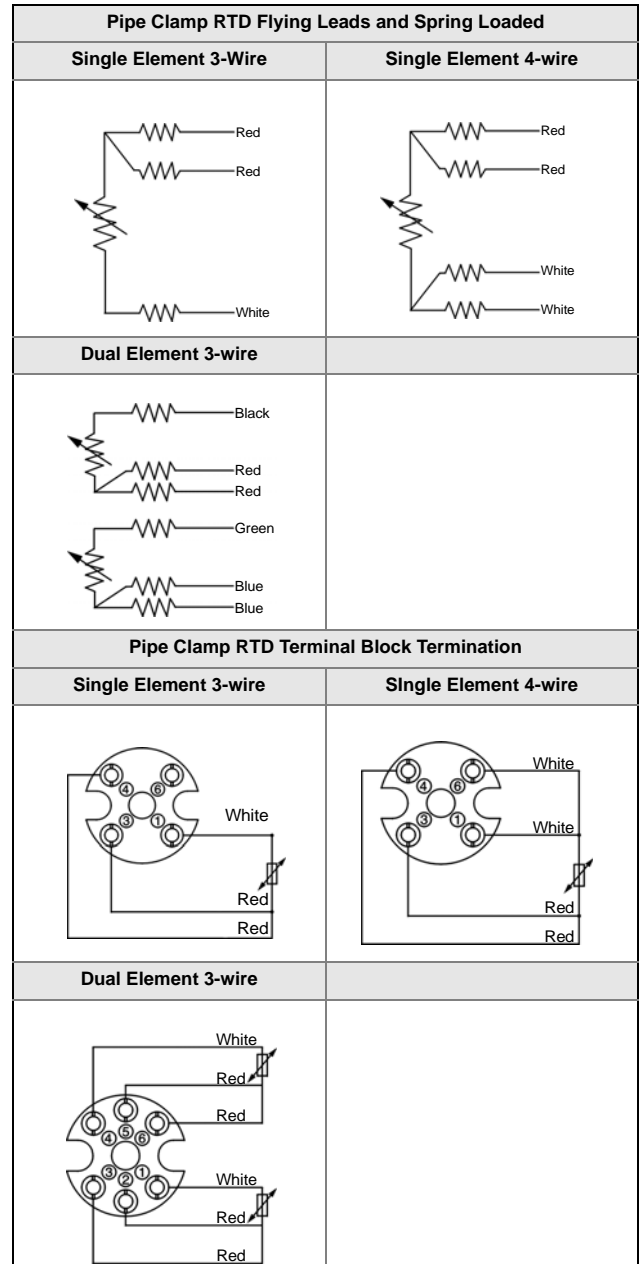

Rosemount Pipe Clamp Sensor

FIGURE 4. RTD Sensor Dimensional Drawings

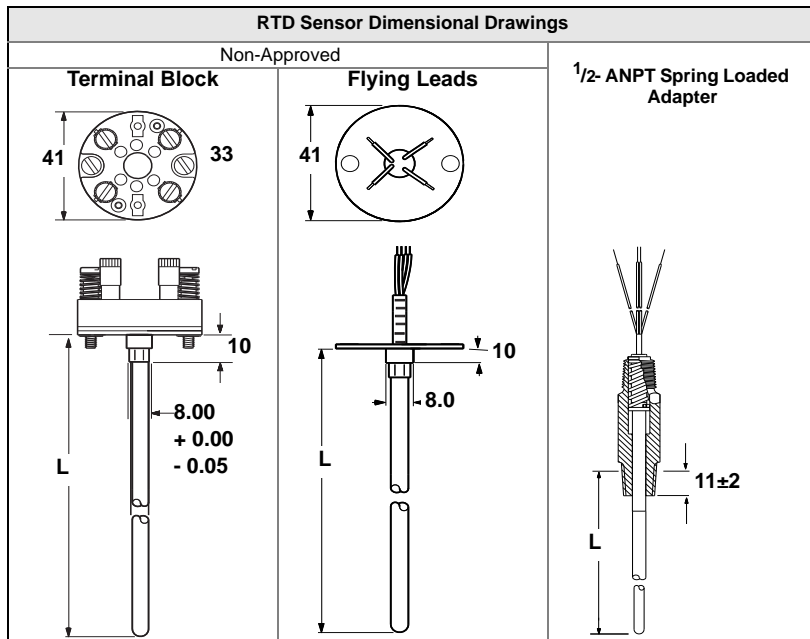
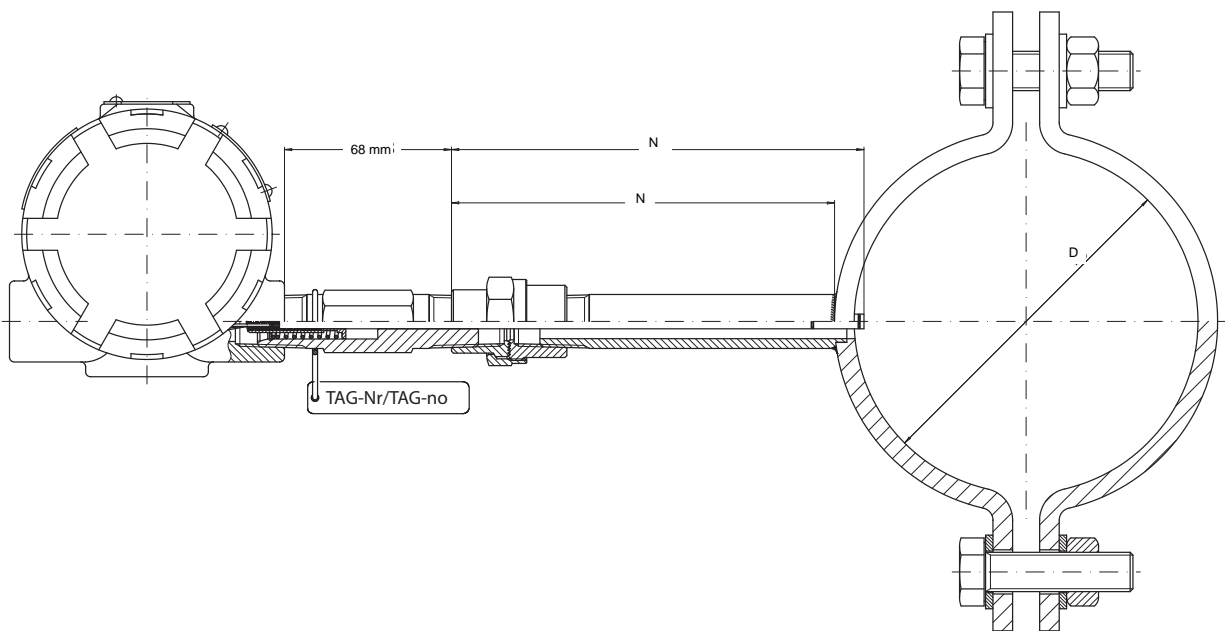

FIGURE 5. Spring Loaded Adapter Sensor Assembly Suitable for Use with Rosemount Transmitter Model 3144P or 648



Product Data Sheet

00813-0100-4952, Rev BB
January 2012

Rosemount Pipe Clamp Sensor

Customer Data Sheet

Rosemount Pipe Clamp Temperature Sensor

Rosemount Pipe Clamp Assembly with Integrated Connection Head or Transmitter Customer Data Sheet

* The Standard offering represents the most common options. The starred options (*) should be selected for best delivery. The Expanded offering is subject to additional delivery lead time.

Customer Information

Customer: _____ Phone: _____ Fax: _____
Contact Name _____ Quote No: _____
P.O./Reference No.: _____ P.O. Line Item: _____
Customer Sign Off: _____

Pipe Clamp Information

Device Tag Name: _____

Hazardous Location Certifications: (Select only one)

- EEx ia - ATEX/IBExU Intrinsic Safety Approval*
- EEx d - ATEX/CELENEC Flameproof Approval*
- No Approval*

Connection Head: (Select only one)

- RMT, Aluminum*
- RMT, Aluminum with LCD Cover*
- No Connection Head*
- RMT, SST*
- RMT, SST with LCD Cover*

Conduit/Cable Entry: (Select only one)

- M20 x 1.5*
- M20 x 1.5 with cable gland*
- 1/2-in. NPT*
- No Cable Entry (For use with no connection Head)

Sensor Lead Wire Termination: (Select only one)

- Flying Leads (For use with spring loaded head mount transmitter)*
- Spring Loaded (For direct Transmitter mounting)*
- Terminal Block (Captive screws for spring loading)*

Sensor Type: (Select only one)

- RTD, Single Element 4-Wire (-50 to 300 °C)
- RTD, Single Element 4-Wire (-110 to 300 °C)
- RTD, Single Element 3-Wire (-50 to 300 °C)
- RTD, Dual Element 3-Wire (-50 to 300 °C)
- RTD, Dual Element 3-Wire (-110 to 300 °C)

Extension Type: (Select only one)

- Nipple-Union 1/2-in. NPT (for TRX and Spring Loaded) (min. length N=80 mm)*
- Nipple-Union 1/2-in. NPT (minimum length N =110 mm)*
- None (for replacement only)*

Extension Length (N):

- 80 mm *(Only for Nipple Union)
- Other _____ (mm) (80 mm to 2000 mm)
- 110 mm *

Clamp and Bolt material: (Select only one)

- 1.4301 (SS304)*
- Duplex
- 1.4571 (SS316Ti) *
- Other _____

Clamp Size (D in mm):

- 34 (1-in.)
- 89 (3-in.)*
- 169 (6-in.)
- 273 (10-in.)
- 61 (2-in.)*
- 115 (4-in.)*
- 220 (8-in.)
- Other _____

Rosemount Pipe Clamp Sensor

Rosemount Pipe Clamp Temperature Sensor

Rosemount Pipe Clamp Assembly with Integrated Connection Head or Transmitter Customer Data Sheet

* The Standard offering represents the most common options. The starred options (*) should be selected for best delivery.

The Expanded offering is subject to additional delivery lead time.

Options: (May select more than one)

- RTD Class A
- Assemble to Transmitter
- Extension Ring (only for use with 2 Transmitters)
- Cover Chain
- NBR Coated Clamp

Sensor Calibrations: (May select more than one)

- Sensor Calibrated to a Fixed Temperature Range (-0 to 100 °C)
- Sensor Calibrated to Customer Specified Temperature Range
- Sensor Calibrated to a Fixed Temperature Range (-50 to 100 °C)
- Sensor Calibrated to a Fixed Temperature Range (-50 to 150 °C)
- Sensor Calibrated to Customer Specified Single Measurement Point

Pipe Clamp Sensor Assembly with Cable Specifications

Rosemount Pipe Clamp Platinum RTD

Nominal Resistance

In accordance with DIN EN 60751, the nominal resistance is defined:

100 Ω RTD at 0 °C

$\alpha = 0.00385 \text{ } \Omega \times \text{ } ^\circ\text{C}/\Omega$, averaged between 0 and 100 °C

Limit Deviations

Tolerance Class B, as standard $t = \pm(0.3 + 0.005 \times [t])$; temperature range -110 to 300 °C

Tolerance Class A, as option $t = (0.15 + 0.002 \times [t])$; temperature range 0 to 250 °C

Process Temperature Range

-110 to 300 °C (-166 to 572 °F)

Ambient Temperature Range

-51 to 85 °C (-60 to 185 °F)

Self-Heating

0.15 K/mW when measured as defined in DIN EN 60751; 1996.

Insulation Resistance (RTD)

1,000 MW minimum insulation resistance when measured at 500 Vac at room temperature

Sheath Material

321 SST with mineral insulated cable construction and silver or nickel plate tip

Cable

PVC/PVC insulated, armored, 0.75 sq mm type, cable gland for armored cable is available upon request.

Identification Data

The model and serial numbers are marked on the cable

Hazardous Locations Certifications

According to EEx ia

Ingress Protection (IP) Rating

Conforms IP65

FIGURE 6. Sensor Lead Wire Termination

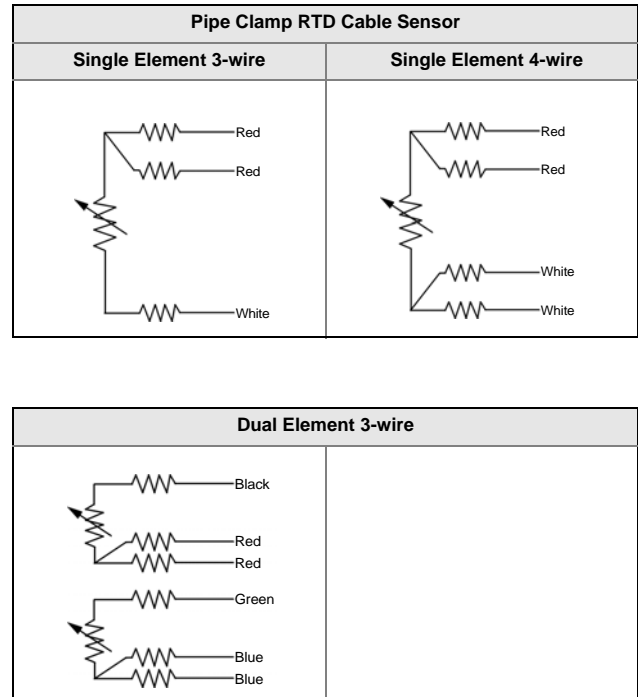

Rosemount Pipe Clamp Sensor

Design Example Drawings

FIGURE 7. RTD Sensor Dimensional Drawings

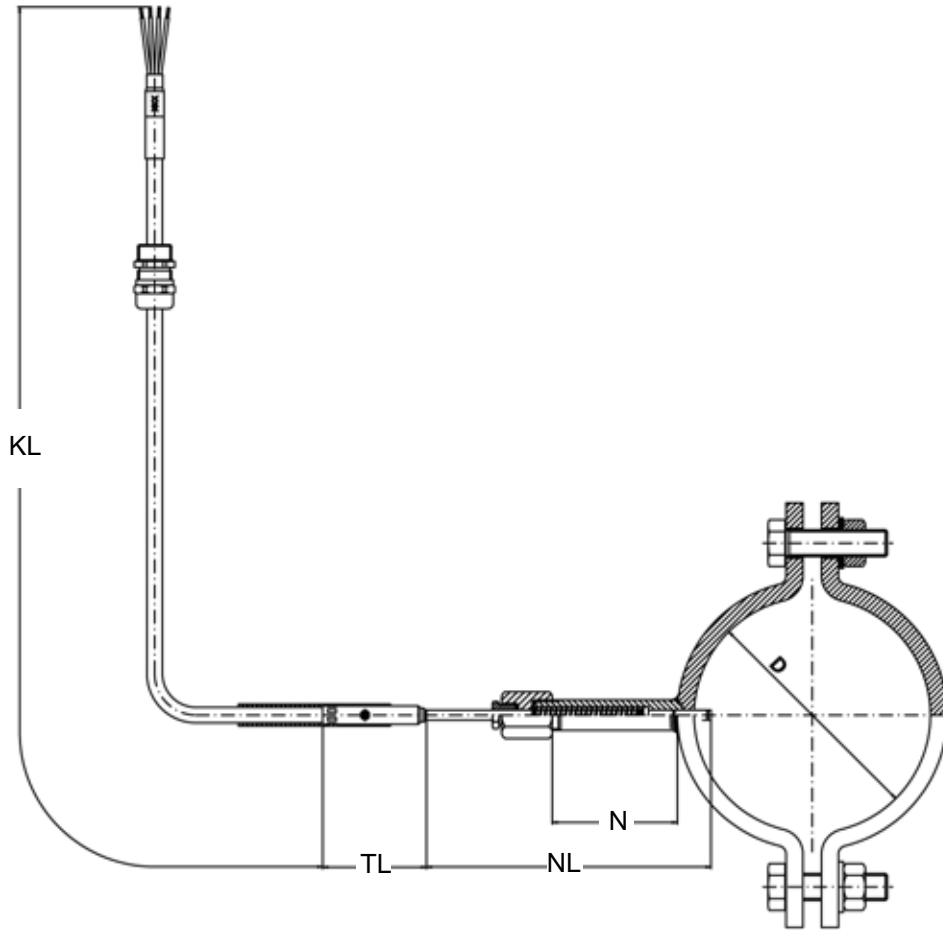

Accessories

TABLE 3. Connection Head

Part Number	Model/Material	IP Rating	Conduit Connection	Process Connection
00644-4410-0011	Rosemount, Aluminium	68	1/2-in. NPT	1/2-in. NPT
00644-4410-0013	Rosemount, Aluminium	68	1/2-in. NPT	M24 x 1.5
00644-4410-0021	Rosemount, Aluminium	68	M20 x 1.5	1/2-in. NPT
00644-4410-0023	Rosemount, Aluminium	68	M20 x 1.5	M24 x 1.5
00644-4410-0111	Rosemount, Aluminium with LCD Display Cover	68	1/2-in. NPT	1/2-in. NPT
00644-4410-0113	Rosemount, Aluminium with LCD Display Cover	68	1/2-in. NPT	M24 x 1.5
00644-4410-0121	Rosemount, Aluminium with LCD Display Cover	68	M20 x 1.5	1/2-in. NPT
00644-4410-0123	Rosemount, Aluminium with LCD Display Cover	68	M20 x 1.5	M24 x 1.5
00644-4411-0011	Rosemount, Stainless Steel	68	1/2-in. NPT	1/2-in. NPT
00644-4411-0013	Rosemount, Stainless Steel	68	1/2-in. NPT	M24 x 1.5
00644-4411-0021	Rosemount, Stainless Steel	68	M20 x 1.5	1/2-in. NPT
00644-4411-0023	Rosemount, Stainless Steel	68	M20 x 1.5	M24 x 1.5
00644-4411-0111	Rosemount, Stainless Steel with LCD Display Cover	68	1/2-in. NPT	1/2-in. NPT
00644-4411-0113	Rosemount, Stainless Steel with LCD Display Cover	68	1/2-in. NPT	M24 x 1.5
00644-4411-0121	Rosemount, Stainless Steel with LCD Display Cover	68	M20 x 1.5	1/2-in. NPT
00644-4411-0123	Rosemount, Stainless Steel with LCD Display Cover	68	M20 x 1.5	M24 x 1.5

FIGURE 8. Connection Head Dimensional Drawing

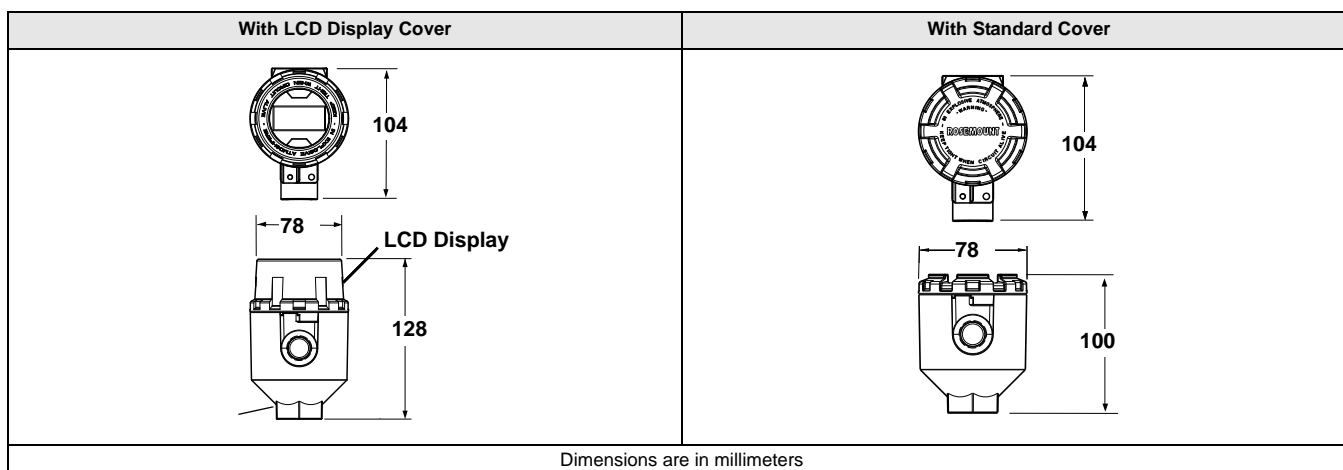

Rosemount Pipe Clamp Sensor

Product Data Sheet
00813-0100-4952, Rev BB
January 2012

*Standard Terms and Conditions of Sale can be found at www.rosemount.com/terms_of_sale
The Emerson logo is a trade mark and service mark of Emerson Electric Co.
Rosemount and the Rosemount logotype are registered trademarks of Rosemount Inc.
PlantWeb is a registered trademark of one of the Emerson Process Management group of companies.
All other marks are the property of their respective owners.*

© 2012 Rosemount Inc. All rights reserved.

TRANSCAT[®]

 Visit us at Transcat.com!