

Moore 40, 41, and 42 Precision Pressure Regulators

FEATURES & BENEFITS

- ▶ Multi-stage, low-droop precision regulators maintain constant output over wide changes in flow and supply pressure
- ▶ Epoxy powder coat paint delivers improved corrosion resistance
- ▶ Wide selection of regulated pressures [1" to 450 psi] affords application versatility
- ▶ Patented Nullmatic pressure regulation system provides reliable maintenance-free operation

DESCRIPTION

The Moore 40, 41, and 42 Precision Pressure Regulators control air pressures in applications where precise and dependable regulation is required, such as pneumatic instrument circuits, test stands, production checking fixtures, and industrial air gages. As such, they are suitable for dead-end service, and flows up to a maximum of 110 scfm.

A unique, two-stage piloted design provides outstanding accuracy. Rugged construction—with no links, levers, pivots, or other friction-producing members—ensures reliable, maintenance-free operation. These features allow a regulator to maintain constant output pressure, regardless of even the widest changes in flow or supply pressures. In fact, a regulator using a Moore 40, 41, or 42 is practically a self-contained pressure controller operating its supply-plunger valve via a built-in, high-gain pneumatic amplifier.

A fine-turn, precision screw is used to manually load the range spring, which sets the regulated pressure. When the adjusting knob is turned clockwise, the increased spring force is exerted on the top diaphragm assembly, decreasing the nozzle clearance and increasing the pilot pressure. Because the source for pilot pressure is supply air flowing to the pilot pressure chamber through the restriction screw, the increased pilot pressure forces the exhaust diaphragm assembly downward. This action closes the exhaust port, and contacts and moves the valve plunger, which opens the supply port. This increases the regulated output, which also feeds back to the top diaphragm assembly. The regulator locks-up or throttles at the new output value when the feedback force of the top diaphragm assembly equals the range spring force.

A safety release valve is incorporated in the top diaphragm assembly of several models. It operates if the regulated pressure increases 3 to 5 psig more than the set pressure and exhausts air through the atmospheric vent in the top housing. Overpressure causes the diaphragm to move upward, which opens the safety release valve.



SPECIFICATIONS

Resolution Adjustment

Better than 0.03° of regulated output

Supply Pressure

Maximum & recommended pressures are listed on page 220
Minimum: 5 psig above regulated output

Supply Pressure Effect

Nominal ratio of change in regulated pressure for a change in supply
1:150 for Moore 40 and 42
1:100 for Moore 41

Ambient Temperature Limits

-40 to 180°F (-40 to 80°C)

Ambient Temperature Effect

Approximately 1% of set pressure with standard range spring; and approximately 0.1% with Isothermal spring for 50°F (27°C) temperature change

Knob Adjustment

Moore 40 & 42:
Nominal 10% of full range for one complete turn
Moore 41:
Nominal 15% of full range for one complete turn

Droop Effect

See Graph 1

Maximum Air Flow

See Graph 2

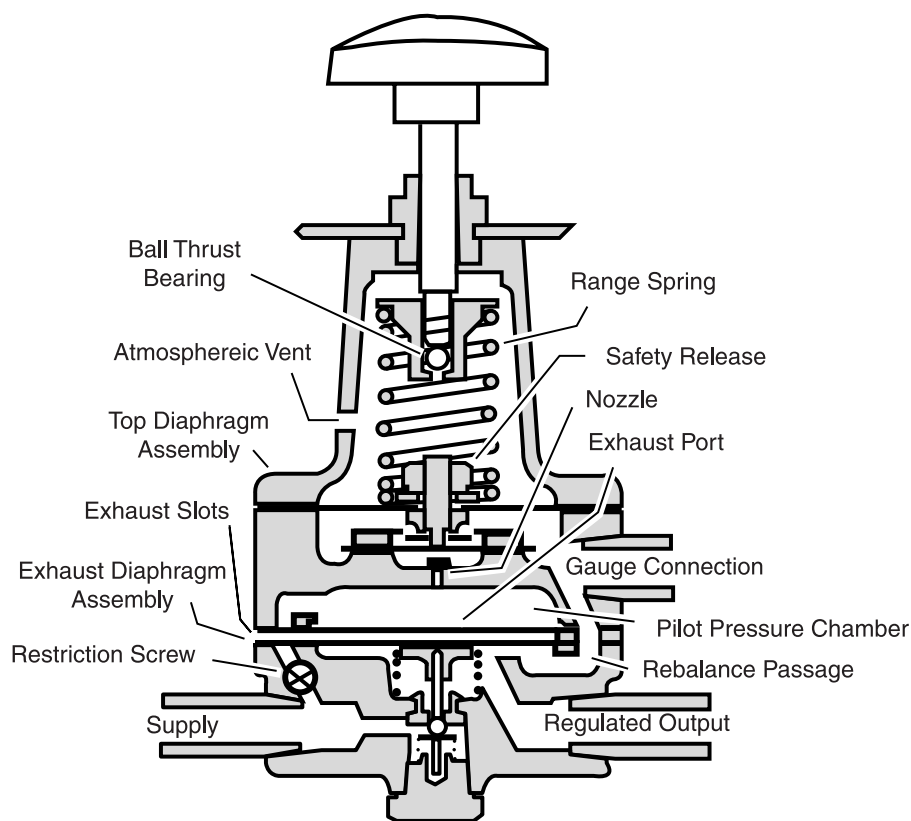

Air Consumption

See Graph 3

Drift Effect

See Graph 4

Exhaust-Flow Rate (at 25-psig setting)

Pressure rise of 0.25 psig will result from flow of:

- Moore 40: 1.5 scfm
- Moore 41: 2.4 scfm
- Moore 42: 1.7 scfm

Maximum Flow Capacity

See Graph on page 219

Standard Mounting

In-line pipe or flush panel up to 1/4" thick (bushing for 3/4" thick panel is optional)

Connections: (supply and outlet)

- Moore 40: 1/4" NPT
- Moore 41: 1/8" NPT
- Moore 42: 1/2" NPT

Materials of Construction

(and materials in contact with regulated media)

Brass, stainless steel, Neoprene, aluminum, and zinc

ACCESSORIES

- ▶ **P/N 2932-19 - Mounting Bracket** for surface mounting (Moore 40 and Moore 42)
- ▶ **P/N 10963-73 - Mounting Bracket** for surface mounting (Moore 41)
- ▶ **P/N 3603-22 - Locknut**

OPTIONS

- ▶ **Air Loading**
Provision for supplementary air loading (100 psig max) in addition to spring loading
Moore 40, 42: 1/4" NPT
Moore 41: 1/8" NPT
Moore 40-2: Not available
Add [A] into the model number.
Example: 40A15
- ▶ **Tapped Exhaust**
Provision for piping exhaust flow away from the regulator
Moore 40, 42: 1/8" NPT
Moore 41: Not available
Add [E] into the model number.
Example 40E15
- ▶ **Isothermal Range Spring**
Reduces ambient temperature effect from approximately 1% of set pressure to approximately 0.1% for a 50°F [27°C] temperature range
Moore 40: 15, 30, 50, & 100 psig ranges
Moore 41: Not available
Moore 42: 30, 50, & 100 psig ranges
Add (M9) to the Moore 40 number.
Add (M26) to the Moore 42 model number.
Example: 40-15M9, 42-30M26



- ▶ **Deletion of Safety Release Valve (SRV)**
The SRV increases exhaust flow capacity when the regulator must exhaust large flows. Deletion of the SRV will improve drift characteristics (see Graph 4). The SRV is not available with the Moore 41. It is standard with:

Moore 40: 2, 7, 15, 30, 50 & H50 pressure ranges
Moore 42: 15, 30, 50, H30, & H50 pressure ranges

To delete the SRV, add an [X] into the model number. *Example: 40X15*

- ▶ **Slotted Adjusting Screw**
Available for all models. This option provides for screwdriver adjustment of the regulator and includes a locknut.
Moore 40: Add (M3) after the model number
Moore 41: Add (M3) after the model number
Moore 41: Add (M20) after the model number
Example: 40-15(M3)

- ▶ **Locknut with Longer Adjusting Screw**
Available for all models. This option prevents inadvertent regulator adjustment.
Moore 40: Add (M13) after the model number. (Note: The Moore 40-2 is standard with the locknut.)
Moore 41: Add (M5) after the model number or order accessory P/N 3603-22.
Moore 42: Add (M3) after the model number
Example: 40-15(M3)

- ▶ **Bushings** for mounting on panels up to 3/4" thick (Standard maximum is 1/4" thick).
Moore 40: Add (M41) after the model number
Moore 41: Not available
Moore 42: Add (M14) after the model number
Example: 40-15(M41)

GRAPH 1 Droop Effect

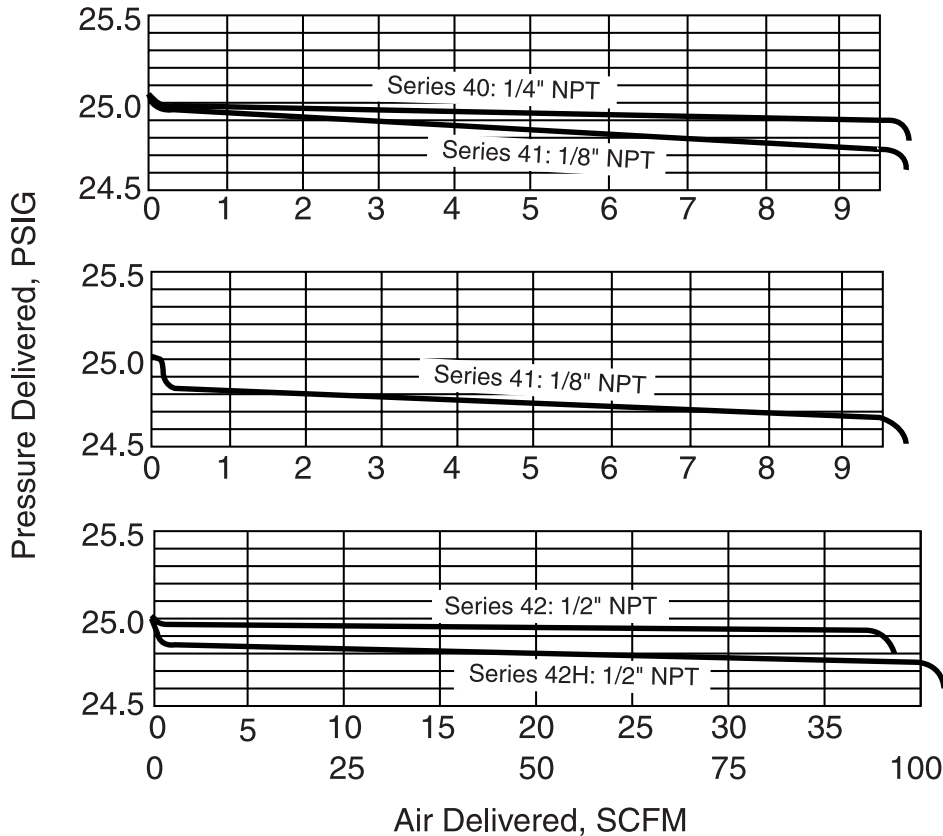

Test Procedure: Each 30-psig-range regulator was adjusted to 25 psig with 100 psig supply and no flow. Flow was increased to maximum capacity. All regulated pressure readings were taken at gauge connection in the body of the regulator.

GRAPH 2 Maximum Air Flow, SCFM Delivered

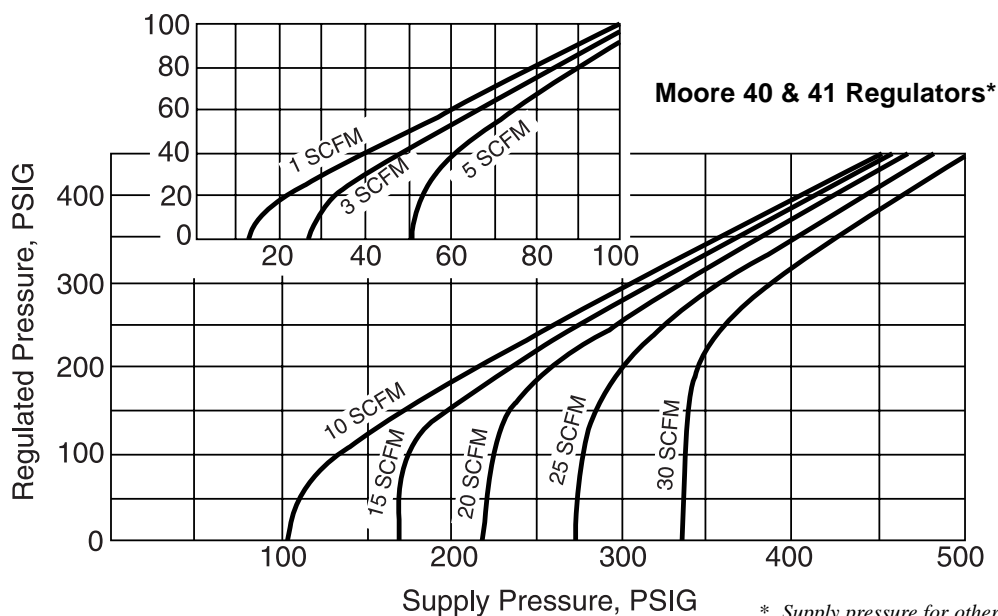

Moore 40 & 41 Regulators*

* Supply pressure for other models will be determined by multiplying the pressure(s) above by the flow values shown below:

Model	Value
Moore 40H	4.5
Moore 42	4
Moore 42H	14

GRAPH 3 Air Consumption

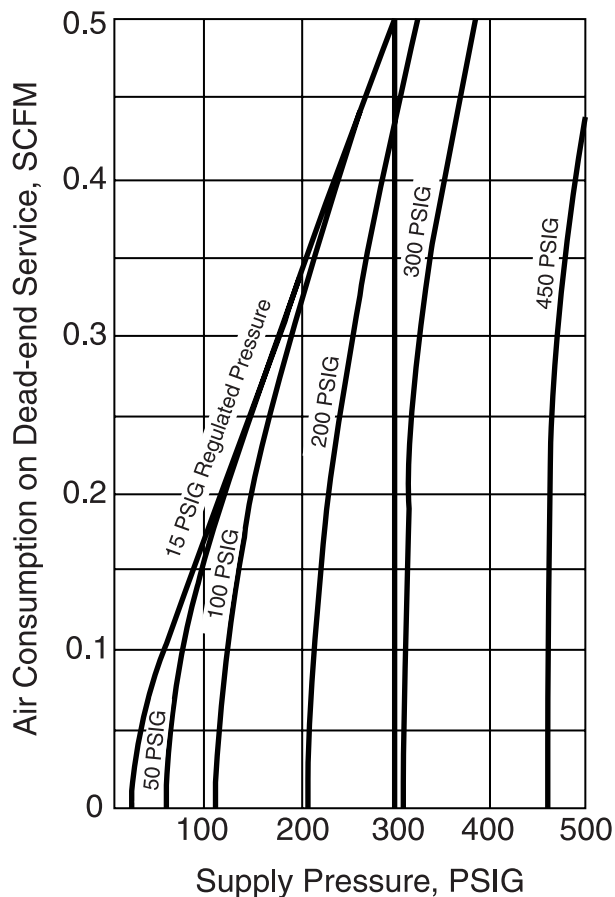

GRAPH 4 Drift Effect

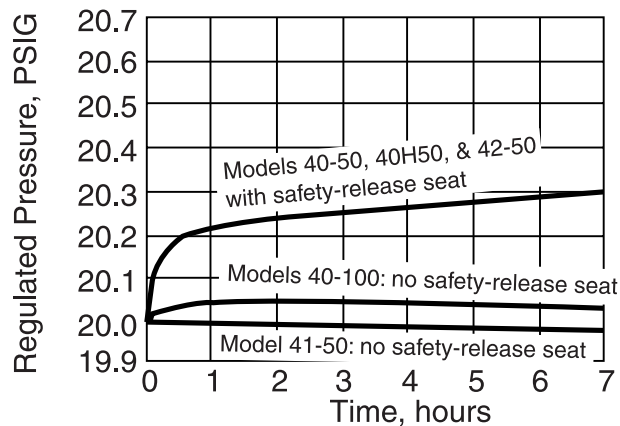

The Nullmatic regulator bleeds only the amount of air that passes through the pilot nozzle when there is no demand for output flow. The exhaust port starts to close as soon as the flow of regulated air is increased to the output, and it closes completely before the pilot-plunger valve opens. Full pilot flow is then delivered to the output.

Test Procedure: Regulators were set at 20 psig output with 100 psig air supply. Supply was turned off for one week, after which supply was turned on at time 0.

MODEL SELECTION

Model No.	Range psig ³	Supply Pressure psig				Gauge (Opt.) Dia. Inches
		Recommended	Maximum	Pipe Mtg.	Panel Mtg.	Standard Modifications
40-2 ¹	(1-50"H ₂ O)	5-10	25	3-1/2	3-1/2	E & X
40-7	(6-200"H ₂ O)	50	100	3-1/2	3-1/2	A, E & X
40-15	0.5-15	75	150	3-1/2	3-1/2	A, E & X
40-30	1-30	120	50	3-1/2	3-1/2	A, E & X
40-50	1-50	120	150	3-1/2 ⁴	3-1/2 ⁴	H, A, E & X
40-100	1.5-100	150	500	3-1/2	3-1/2	H, A & E
40-200	3-200	250	500	3-1/2	3-1/2	A & E
40-300	7-300	350	500	3-1/2	3-1/2	A & E
40-450	15-450	500	500	3-1/2	3-1/2	A & E
41-15	0.5-15	75	150	2 ⁵	3-1/2	A
41N15 ²	0.5-15	75	150	2 ⁵	3-1/2	
41-30	1-30	120	150	2	3-1/2	A
41-50	1-50	120	50	2 ⁴	3-1/2 ⁴	A
41-100	1.5-100	150	250	2	3-1/2	A
41-2550	25-50	120	150	2	3-1/2	
42-15	0.5-15	75	150	3-1/2	3-1/2	A, E & X
42-30	1-30	120	150	3-1/2	3-1/2	H, A, E & X
42-50	1-50	120	150	3-1/2 ⁴	3-1/2 ⁴	H, A, E & X
42-100	1.5-100	150	500	3-1/2	3-1/2	H, A & E
42-200	3-200	250	500	3-1/2	3-1/2	A & E

NOTES:

- (1) Includes locknut on adjusting stem (optional for all other models).
- (2) For use with Model 65 Square-Root Extractor to maintain minimum 3 psig output.
- (3) At recommended supply pressure.
- (4) With 0-60 psig dial range.
- (5) For pipe-mounting, 2" dia. gauge (0-30 psig) is available.

Standard Modifications

H - High flow capacity.

A - With pressure-tight top housing, containing 1/4" NPT connection for supplementary air loading.

E - With 1/8" NPT connection to collect exhaust when used with gases other than air.

X - Without safety release.

MOUNTING DIMENSIONS

Moore 40

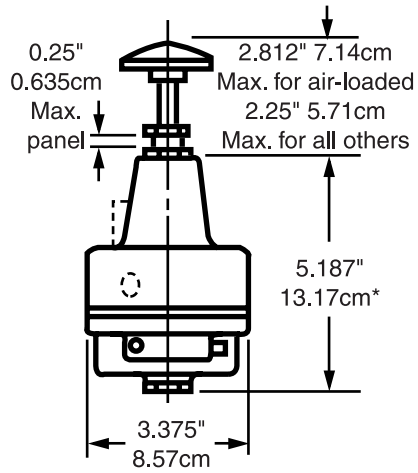

Pipe or Bracket-Mounted with Gauge

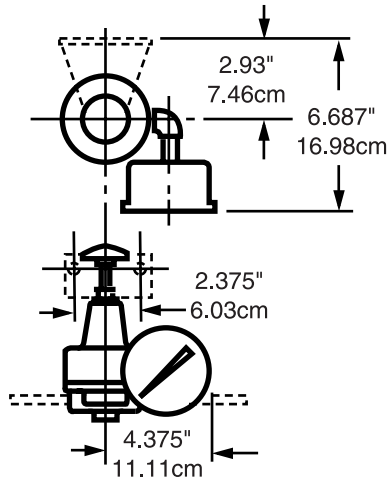

Panel-Mounting with Gauge

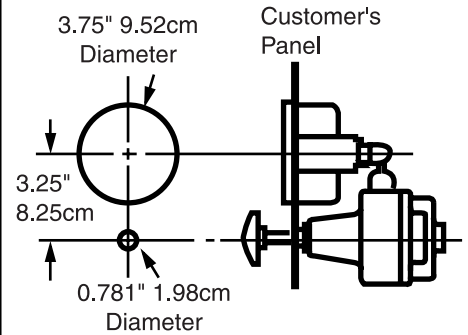

Moore 41

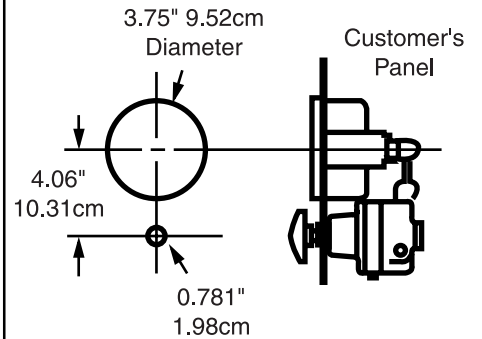
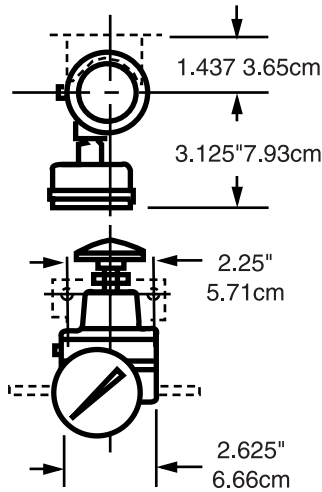
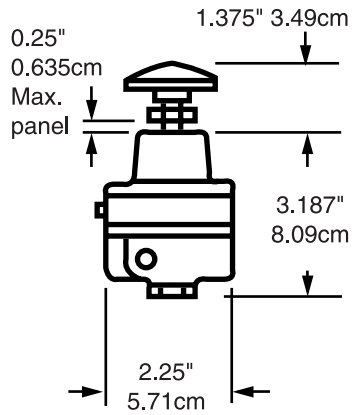

Moore 42

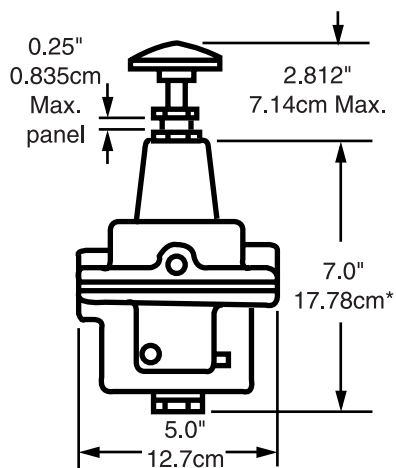

*Add 0.125" 0.31cm
for 200 ppsig Models

